

DATE: June 30, 2023

DEPARTMENT OF GENERAL SERVICES
BUREAU OF CAPITAL PROJECT DESIGN MANAGEMENT
1800 HERR STREETS
HARRISBURG, PENNSYLVANIA

ADDENDUM NO. 30

on

PROJECT NO. DGS C-0211-0005 PHASE 005
PROJECT TITLE - PA State Police Academy - Core Bldgs, BESO & Sitework
PROFESSIONAL:
SOM
7 World Trade Center
New York, NY, 10007

If you submitted a bid prior to this Addendum being issued, your bid has been discarded and you must re-submit your bid(s) prior to the bid opening date and time.

GENERAL CHANGES – ALL CONTRACTS

Item 1 - **PLEASE NOTE:** This is a re-upload of **Addendum 29**, with attached drawings, specifications and references throughout to **Addendum 29**.

Item 2 - Please note the following:

Final questions must be submitted via e-Builder no later than 5:00 PM ET on Tuesday, July 18.

Final Addendum will be issued via e-Builder no later than Tuesday, July 25th.

Bids are due by Tuesday, August 1, no later than 2:00 PM. This is a very tight bidding schedule so please manage your time effectively.

Item 3 - Addendums for this bid begin with Addendum 24. Please note that Addendums 1-23 were issued in the course of the previous bid process and can be disregarded for the purposes of this bid. Items issued in addendums from the previous bid process have been incorporated into the current, re-issued bid documents.

Item 4 - Additional individuals from any bidder wishing to gain access to the bid documents must register through eMarketplace and create an account to access e-Builder. Access cannot be granted in any other fashion.

Item 5 - The optional pre-bid conference was held at the Pennsylvania State Police Academy on Friday, June 16 as notified in Addendum 26. Issued with the addendum are materials presented by SOM at that meeting for reference only. Concept phasing diagrams are shared for reference only, final phasing to be coordinated by contractors under means & methods of construction.

Item 6 - In response to questions submitted, please note the following:

.1 CONTRACT

- Question 72: CLT: What aspect of the CLT is delegated design? The documents indicate size, species and loading. Please advise.
- Response: The entire CLT construction should be delegated design to satisfy the design requirements in Mass Timber notes on GEN-S-016 and APA PRG 320. The CLT construction includes CLT panel and connections. The proposal of using alternative species should meet the required design strength and APA PRG 320. However, Douglas Fir should be used at the bottom exposed layer for architectural aesthetics, refer to Mass Timber notes on GEN-S-016.
- Question 73: CLT: Spec section 061719 - 2.1 - B indicates a certification showing timber is to be sustainably sourced and harvested. What are the sustainability requirements?
- Response: Acceptable industry standard certifications include the following: Forest Stewardship Council (FSC), Sustainable Forestry Initiative (SFI), American Tree Farm System (ATFS), and Canadian Standards Association (CSA).
- Question 74: CLT: Spec section 061719 - 2.1 - G indicates FRT treatment is required. It is our understanding that CLT cannot be fabricated with FRT lumber. Please advise.
- Response: Refer to revised specification 061719 as revised in Addendum 29. FRT treatment has been removed.
- Question 75: Glulam: Spec section 061800 - 2.1 - B indicates a certification showing timber is to be sustainably sourced and harvested. What are the sustainability requirements?
- Response: Acceptable industry standard certifications include the following: Forest Stewardship Council (FSC), Sustainable Forestry Initiative (SFI), American Tree Farm System (ATFS), and Canadian Standards Association (CSA).
- Question 83: Addendum #27 Question 26: The answer to this question is that the .1 and .2 contractors need to coordinate electricity and fuel requirements for temporary heat. That can't be done until after contracts are awarded so the .1 contractor doesn't know what to include in bid for fuel and electric for temporary heat. Please advise.
- Response: Bidders are to provide bids for estimation of temporary heat provisions during construction. Further adjustment requiring coordination with other contractors will be coordinated after award.
- Question 84: Owner Parking: What are the parking requirements, per phase, that need to be maintained for the Owner?
- Response: 125 spaces to be provided on site, remaining owner spaces will be provided off-site at adjacent facility, coordinated by owner.
- Question 85: Addendum 27 Questions 28 and 29: The answer provided on these is to coordinate with Package 2.1 contractor. This doesn't provide any direction for bidding purposes. We need to know the duration provided for these two buildings in order to insert into our schedule. Please advise.
- Response: Durations for not-in-contract work will be coordinated after award.
- Question 86: Addendum 27 Question 35 TE-01: Response to Question 35 regarding TE-01 only tells us that the fence is 6' tall. Please provide details. What is the gate width? Spec 323113 says 3' but that doesn't make sense for a trash enclosure. Are there bollards? Are we to scale the size of these enclosures?
- Response: Please see new detail 3/STE-L-901 for additional information on gate width, bollards, and general sizing for trash enclosures included in Addendum 29. Specification section 323113 has been revised.

- Question 89: Addendum 27 Question 46: Addendum 27 Response #46 calls for us to provide a lump sum to underpin/support the existing building. The EOR needs to provide the extent of underpinning required in order to price. We don't have locations, dimensions, depths, quantities, or existing drawings to provide a price for this work.
- Response: Refer to Question 3 response as issued in Addendum 24. The evaluation of the of the existing building to remain adjacent to the soil nail wall is part of the soil nail wall design. Contractor bids should include the cost to retain a Professional Engineer licensed in Pennsylvania to design all aspects of the soil nail wall including any necessary support of the adjacent existing building to remain during construction that are deemed necessary as part of the soil nail wall design to allow construction of the soil nail wall without impacting the existing building. The contractor's engineer must determine the type of support, locations, dimensions, depths and quantities of any support required to the existing building. No drawings are available for the existing building to remain; any exploration of the building foundations needed for the design should be included in the bid cost.
- Question 92: Excavation: Please confirm that the .2, .3, and .4 contractors have all of their own excavation and backfill within 5' of the buildings and within the building footprints.
- Response: The .1 General Contractor is responsible for all excavation & backfill. The .1 General Contractor is responsible for installation for incoming service duct bank and all utility work 5' outside the building footprints.
- Question 93: Geothermal Excavation: Please confirm the .2 contractor is responsible for excavation and backfill for geothermal work since this is delegated design and is not currently shown on the documents.
- Response: The .1 General Contractor is responsible for all excavation & backfill. Work will need to be coordinated with .2 contractor during construction. Bidders are to provide bids for estimation of excavation during construction.
- Question 94: Generator Conduit: On drawing STE-C-701 the emergency generator conduit to the Marquee building runs through the existing building that needs to remain during the Marquee construction. Please advise.
- Response: Refer to revised drawing STE-C-701 as issued in Addendum 29 for the emergency generator conduit routing around existing academy.
- Question 95: Parking for Marquee: Please confirm what parking is needed to be turned over when the Marquee building is occupied.
- Response: 125 spaces to be provided on site through duration of project, remaining owner spaces will be provided off-site at adjacent facility, coordinated by owner.
- Question 96: Wage Rates: Please confirm the wage rates provided are good for the entire duration of the project. If not, please provide wage rates for entire duration.
- Response: Confirmed, bidders are only responsible for wage rates at time of issuance.
- Question 97: Excess Soils: Please confirm all excess soils can be placed on the site and that they don't need to be hauled away.
- Response: The design intent is that no material will be exported from the site. Please note that 20,000 CY of export material from this contract must be coordinated with adjoining contract area as shown on plans. Any remaining material could either be further coordinated with adjoining contract or spoiled on undeveloped areas on the site within the limit of disturbance.

- Question 98: Site Electric: Please confirm that the prime electrical contractor will have excavation and backfill and duct banks for the site electric. Profiles, amount of pipes, and pipes sizes are not provided for the .1 contractor to price this work.
- Response: The .1 General Contractor is responsible for excavation, backfill, duct banks, concrete encasement, manholes and any associated site work. The .4 Electrical contractor is responsible for all raceways, conduits, cabling initiated at the switchgear.
- Question 99: Masonry: Drawings ITV-A-111 and ITV-A-602 shows a masonry partition along column line M10 that does not have a label. Please confirm N1 is the correct masonry partition type.
- Response: Response will be provided in an upcoming addendum.
- Question 100: Masonry: The exterior masonry walls in the Auditorium of the Marquee Building are not completely labeled. Only the exterior finish is labeled as CMU-01 however, the backup CMU does not have a label. Please confirm CMU-08A is correct. See MAQ-A-568, 1/MAQ-A-515, 3/MAQ-A-565, MAQ-A-516, GEN-A-520 for reference.
- Response: Backup walls to be CMU-08 per Wall Type buildup described on GEN-A-500 - EXTERIOR WALL TYPES. For Wall Type, see MAQ-A-500 - WALL TYPE KEY ELEVATION.
- Question 101: Phasing Plan: A phasing plan was shared at the pre-bid meeting but was not issued in Addendum #28. Please provide.
- Response: Presentation is issued in Addendum 29 for reference only, final phasing to be coordinated by contractor under means & methods of construction.
- Question 102: STE-L-900: Please confirm where detail 8/STE-L-900 applied. I don't see where PV 4.0 is set up against the building and the Materials Schedule doesn't show PV 4.0 getting a concrete setting bed below it. PAV-03 is shown up against the building and does have a concrete setting bed underneath.
- Response: Detail occurs at paving that leads to main/central entry to Marquee Building. See revised detail in Addendum 29 drawings which indicates PAV-03 in lieu of PV 4.0.
- Question 103: Splash Pad: 4/STE-L-901 shows details for a splash pad and there a few questions regarding these details. A) Where are these splash pads shown in plan to quantify them? B) These details reference a material ST which doesn't show up in the material schedule to know that ST is. C) Please provide details for the concrete trench. D) Details points to a 4" wide concrete trench under ST but the concrete is shown to go up to grade. Please advise.
- Response: A) Refer to Sheet STE-L-104_D for splash pad location. B) ST revised to LST-01 C) Please see revised detail 4/STE-L-901 included in Addendum 29. D) Please see revised detail 4/STE-L-901 included in Addendum 29.
- Question 104: Retaining Walls: STE-C-454 has a detail for retaining wall. 5/STE-L-901 also has detail for site retaining wall. Please confirm which details apply where.
- Response: Detail 5/STE-L-901 only applies to the site wall explicitly called out in the Landscape drawings on Sheet STE-L-104. Refer to Civil details for all other site retaining walls.
- Question 105: Drain Covers: Spec 321400 2.2 and 2.3 call for drain covers in the unit pavers and mention to see material schedule and drawings for material type, size, and finish. Please confirm where this information is shown on the drawings.
- Response: 321400, 2.2-2.3 are not applicable and have been removed from the Specification.

- Question 106: Bollards: STE-C-451 has a bollard detail and STE-L-901 has a different bollard detail. Please confirm which detail goes where.
- Response: Bollards shown in details 2/STE-L-901 and included in Materials Schedule apply only to bollards explicitly called out in the Landscape drawings on Sheets STE-L-104 and STE-L-104_D. All other bollards, including at trash enclosure should follow the Civil detail.
- Question 107: Abatement: Spec 020800 notes that all layers of flooring needs to be removed at areas where ACM is identified. Please confirms types of flooring and layers where ACM is identified in order to provide a price.
- Response: Response will be provided in an upcoming addendum.
- Question 108: Abatement: Abatement spec 020800 and H series drawings note that Abatement contractor is responsible for all ACM removal whether it has been identified or not. This is not quantifiable or reasonable for a hard bid situation to know what cost to include. Please provide specific direction/quantities or an allowance for this work.
- Response: Response will be provided in an upcoming addendum.
- Question 109: Builder's Risk: We are being told by our builder's risk broker that the Marquee building could be classified as a mass timber project and will require special insurance. Should this building be classified as mass timber?
- Response: Response will be provided in an upcoming addendum.
- Question 110: Existing Kennel Buildings: Spec section 013110 notes that the existing kennel building can be demolished at any time for the construction of the BESO building. At the pre-bid, it was mentioned that the BESO building needed to be in phase 2. Please confirm.
- Response: Response will be provided in an upcoming addendum.
- Question 111: Geothermal Wells: Do all of the geothermal well fields need to be installed and activated for the turnover of the Marquee building? If so, this creates a phasing issue with the existing buildings that need to remain during the construction of the Marquee building such as, stables, garage building A, garage building b, and existing headquarters.
- Response: Response will be provided in an upcoming addendum.
- Question 112: Temporary Access Roads: Drawing STE-C-811 shows a conceptual access road the goes through a drainage basin and yard inlet. Please advise.
- Response: Response will be provided in an upcoming addendum.
- Question 113: Food Service: Please confirm the Hot Line Serving M-1205A casework and countertops are part of the Food Service Equipment package. If not, please provide section details and labels for the casework and countertops. Reference MAQ-QF-111.
- Response: Confirmed, All equipment and casework in M-1205A, Hot Line Serving, are part of the Food Service Equipment package.
- Question 114: Servery: Please confirm the cabinets of the Cold Line Servery M-1204 and Beverage Station M-1202 part of the Food Service Equipment package. Reference MAQ-QF-113.
- Response: Confirmed, All equipment and casework in M-1204, Cold Line Serving, are part of the Food Service Equipment package.

- Question 115: FTU Wall: FTU Site wall detailed on 5/GEN-A-521 indicates a fully grouted CMU backup wall, however, the backup CMU wall is labeled as CMU-01A, which is a 4" split face CMU. Please confirm R2 or N12 is the correct CMU type.
- Response: Site wall to be CMU-02 backup, faced with CMU-01. See 5/, 11/GEN-A-521 as issued in Addendum #29. Please note that CMU-01A is an 8x8x24 block per 042000.2.3.B
- Question 116: Ceiling Trim: Specification Section 092116 Gypsum Board Assemblies 2.7 Trim Accessories B. Metal Specialty Accessories 1. (call out the following) b. Channel Wall Reveal, c. Rounded Outside Corner d. Base Reveal e. W-Reveal f. Corner Trim g. Column Collar h. Partition End Caps. I do not see any of these trims shown on the drawings. Are any of these trims to be used in the project?
- Response: Response will be provided in an upcoming addendum.
- Question 117: Abuse vs impact: Specification Section 092166 Gypsum Board Assemblies 2.4 Gypsum Board Materials Gypsum Board 1. Provide Abuse Resistant Panels for the first 8 ft. of all gypsum board partitions, unless otherwise indicated. 3.4 C. Panel Materials 1. General Install Impact Resistant panels for the first 8ft. of all gypsum board partitions. Please clarify either Abuse or Impact board. There is a significant difference in cost.
- Response: Response will be provided in an upcoming addendum.
- Question 118: Masonry: Drawing note B1 in the BSO-A drawings reads "SEE STRUCTURAL" regarding load bearing CMU, however, there is no information regarding load bearing CMU in the BSO-S drawings. Please advise.
- Response: Refer to BSO-S-101.

.2 CONTRACT

- Question 2: HVAC -1: Specification 230700 3.1 K. Ductwork Table - Lists Insulation type "D" for Exposed insulation in mechanical rooms or areas subject to damage. There is no specification for Type D insulation. Provide if applicable.
- Response: Refer to revised specification section 230700, as issued in Addendum 29.
- Question 3: HVAC-2: Specification 230700 3.1 L. Pipe Table - Lists Insulation type "4" for many pipes. There is no specification for Type 4 insulation. Provide if applicable.
- Response: Refer to revised specification section 230700, as issued in Addendum 29.
- Question 4: HVAC-3: Drawing BSO-M-402 B-CRAC-1 has no associated condensing unit associated. Provide Unit schedule with performance and electrical characteristics and location.
- Response: Refer to BSO-M-402 CRAC Unit Schedule, Note 2 states that B-CRAC-1 is a self contained unit. No external CU needed. Heat rejected to return area plenum.
- Question 5: HVAC-4: Drawing BSO-M-401 Split System Condensing Units B-CU-1 has a scheduled capacity of 600MBH while corresponding B-AHU-1 has a scheduled total DX capacity of 646.3MBH. Confirm this is correct.
- Response: Scheduled condensing unit confirmed. B-AHU-1 has a coil capacity of 637 MBH and B-CU-1 has a nominal capacity of 600 MBH.
- Question 6: HVAC-5: Drawing BSO-M-401 Split System Condensing Units B-CU-7 lists related fan as B-FCU-3. Confirm this should be B-FCU-6.

- Response: Confirmed, this should be FCU-6. Refer to revised drawing BSO-M-401 as issued in Addendum 29.
- Question 7: HVAC-6: Specification 230933 1.5 3. c. & 1.5 4. e. states control conduits provided by electrical contractor. While 230933 3.1 A. 4. States all control conduits shall be provided by range ventilation contractor.
- Response: Spec 230933 3.1 A.4 applies to indoor firing range (FTU) building. For that building range ventilation contractor is to provide controls conduit. For all other buildings, Spec 230933 1.5.3.c & 1.5.4.e applies and controls conduit to be provided by electrical contractor.
- Question 8: HVAC-6: Specification 230933 1.5 3. c. & 1.5 4. e. states control conduits provided by electrical contractor. While 230933 3.1 A. 4. States all control conduits shall be provided by range ventilation contractor. Confirm who is providing / installing control conduit.
- Response: Spec 230933 3.1 A.4 applies to indoor firing range (FTU) building. For that building range ventilation contractor is to provide controls conduit. For all other buildings, Spec 230933 1.5.3.c & 1.5.4.e applies and controls conduit to be provided by electrical contractor.
- Question 9: HVAC-7: M-DEF-1 & M-DEF-2 dryer exhaust fans: Provide control sequence for M-DEF-1 & M-DEF-2 dryer exhaust fans.
- Response: Refer to revised MAQ-M-807 as issued in Addendum 29, including sequence of operations for M-DEF-1 & M-DEF-2 dryer exhaust fans.
- Question 10: HVAC-8: Specification 015000-3 1.4 k. states the Lead Contractor is to provide appropriate ventilation, dehumidification, humidification and cooling to meet building finish requirements. Specification 230000 3.14 A. instructs the Mechanical Contractor to do the same. Provide clarification of this duplication in scope.
- Response: Responsibility for General Contractor. Refer to revised specification section 230000 as issued in Addendum 29.
- Question 11: HVAC-9: Control Sequence: Provide a Control Sequence of Operation for G-DHU-1 serving Tank Training.
- Response: SOO on GYM-M-800 applies to G-DHU-1. SOO title to be revised to include G-DHU-1 in name. Refer to revised GYM-M-800 as issued in Addendum 29.
- Question 12: HVAC-10: GYM -M-122 depicts (2) 14" branch ducts serving Cardio Area (G-151); the branch ducts never reduce in size for the entire run of SG-1 outlets. Confirm this is the intent.
- Response: Confirmed, intent is to keep at 14".
- Question 13: HVAC-11: Mechanical Equipment Anchorage : General Detail for Mechanical Equipment Anchorage (all buildings) states that if anchorage embedment depth is deeper than ½" contractor shall hire a California registered structural engineer to perform analysis and calculations as required by the landlord. Confirm if this is applicable to the project.
- Response: Reference to California registered structural engineer is removed. Refer to revised MAQ-M-701, GYM-M-701 and FTU-M-701 drawings as issued in Addendum 29.
- Question 14: HVAC-12: Drawings MAQ-M-700 & BSO-M-701 depict a detail for: Slot with Integral Volume Damper. Note A. states: All slot diffusers located in ceilings are to be provided and installed by the ceiling contractor (S.A.D.). Confirm this is the intent.

- Response: Reference to be installed by ceiling contractor is removed. Refer to revised drawings MAQ-M-700 and BSO-M-701 as issued in Addendum 29.
- Question 15: HVAC-13 Drawing BSO-M-402 Diffuser, Register and Grille Schedule. CD-1, provide round neck size.
- Response: Refer to revised BSO-M-402 as issued in Addendum 29, indicating round neck size.
- Question 16: HVAC-14 Drawing BSO-M-121 BESO Lounge B-222 shows (4) CD-1 Diffusers at 300 CFM/Ea. Scheduled airflow for CD-1 is 200 CFM Max. Confirm this is correct.
- Response: Diffusers serving BESO Lounge B-222 should be CD-4. Airflows confirmed correct. Refer to revised BSO-M-121 as issued in Addendum 29 indicating correct diffuser type.
- Question 17: HVAC-15 Drawing BSO-M-111: Drawing BSO-M-111 K9 Classroom B-129 depicts (1) CD-1/185 CFM. What is the other ceiling diffuser designation and air flow in this room.
- Response: CD-1/185 cfm is typical for both diffusers in B-129 K9 Classroom. Refer to revised BSO-M-111 as issued in Addendum 29.
- Question 18: HVAC-16 Specification 230700 3.1, L.Breeching Insulation Table – Breeching, Generator Exhaust Lists only Type 3 Insulation. Provide Type 3 Insulation Specification. ALSO, Heating and Chilled Water Storage and Air Separation Tanks and Heat Exchangers (Steam & Hydronic) lists Type 5 Insulation. Provide Type 5 Insulation if applicable.
- Response: Refer to revised spec section 230700 as issued in Addendum 29, clarifying types 3 and 5.
- Question 19: HVAC-17 Specification Section 230517: References are made referring to Specification Section 230517 “Sleeves and Seals for HVAC Piping”. Provide 230517 Section if applicable.
- Response: Response will be provided in an upcoming addendum.
- Question 20: HVAC-18 Control Sequence for Unit G-DHU-1: Provide a control sequence for Unit G-DHU-1 serving Training Tank G-130.
- Response: Reference response to question 9 and revised documents as issued in Addendum 29.
- Question 21: BESO Building: Please clarify the emergency generator BAS integration and controls scope.
- Response: Refer to revised control drawings as issued in Addendum 29 clarifying generator monitoring.
- Question 22: Marquee Building: Please clarify the emergency Generator BAS integration and controls scope.
- Response: Refer to revised control drawings as issued in Addendum 29 clarifying generator monitoring.
- Question 23: PICVs: Regarding specification section 230900, 2.14, F, 4: Please clarify locations and BAS monitoring for PICVs.
- Response: Refer to control drawings for BAS monitoring requirements and plan drawings for equipment locations
- Question 24: ePICVs: Regarding specification section 230900, 2.14, G: Please clarify locations and BAS monitoring for ePICVs.
- Response: Refer to control drawings for BAS monitoring requirements and plan drawings for equipment locations
- Question 25: Construction Schedule: Please provide building construction schedules.
- Response: Building construction schedule is being coordinated by .1 General Contractor and will be provided after award. Refer to spec section 013110 for critical milestones.
- Question 26: Firearms Training Unit: Does the firing range control system integrate into the BAS?
- Response: Yes. Refer to controls drawings.

- Question 27: 3rd Party Integration
- Response: Spec section referenced provides direction for controls contractor to intergrate points as shown on controls drawings regardless of protocol.
- Question 28: Electric Meters: Specification 230900, 2.3, D, 9, d refers to electrical meter reporting but electrical meters are not shown on the electrical drawings. Please verify meter location(s).
- Response: Electrical meters are on one line diagrams, refer to electrical drawings.
- Question 29: Gas Meters: Specification 230900, 2.3, D, 9, e refers to gas meter reporting but gas meters are not shown on the plumbing drawings. Please verify meter location(s).
- Response: Plumbing drawings show gas meters, refer to plumbing drawings.
- Question 30: Airflow Station Alternates: Regarding specification 230900, 2.14, I, 3: Are Accutrol duct mounted airflow stations an acceptable alternate?
- Response: Provide equipment as listed in specifications, alternates will not be accepted prior to award.
- Question 31: Ethernet Cabling Responsibilities: Please clarify who is responsible for ethernet cabling from the data closets to IP based BAS control panels and equipment with BAS IP integration.
- Response: Response will be provided in an upcoming addendum.
- Question 32: Marquee Building: Please clarify if there is any BAS integration or monitoring for the trench heaters.
- Response: BAS integration is not required.

SPECIFICATION CHANGES – ALL CONTRACTS

Item 1 - Please refer to the attached documents for updated specifications as described in responses to questions and listed below.

NUMBER / NAME / ACTION

061719 / Cross Laminated Timber / Revised
 230000 / Heating, Ventilating and Air Conditioning (HVAC) Basic Requirements / Revised
 230700 / HVAC Insulation / Revised
 321400 / UNIT PAVING / Revised
 323113 / CHAIN LINK FENCES & GATES / Revised

DRAWING CHANGES – ALL CONTRACTS

Item 1 - Please refer to the attached documents for updated drawings as described in responses to questions and listed below.

NUMBER / NAME / ACTION

STE-L-110 / MATERIALS SCHEDULE / Revised (schedule revised)
 STE-L-900 / HARDSCAPE DETAILS / Revised (paver detail clarified)
 STE-L-901 / HARDSCAPE DETAILS / Revised (paver detail clarified)
 GEN-A-521 / TYPICAL CMU DETAILS / Revised (Detail annotation revised)
 MAQ-M-700 / AIRSIDE DETAILS / Revised (note revised)
 MAQ-M-701 / AIRSIDE DETAILS / Revised (note revised)
 MAQ-M-807 / CONTROLS - MECHANICAL / Revised (Controls clarified)
 GYM-M-700 / AIRSIDE DETAILS / Revised (note revised)
 GYM-M-701 / AIRSIDE DETAILS / Revised (note revised)
 GYM-M-801 / CONTROLS – MECHANICAL / Revised (Controls clarified)
 FTU-M-700 / AIRSIDE DETAILS / Revised (note revised)
 FTU-M-701 / AIRSIDE DETAILS / Revised (note revised)
 FTU-M-802 / CONTROLS - MECHANICAL / Revised (Controls clarified)
 BSO-M-111 / FLOOR PART PLAN B - LEVEL 1 -MECHANICAL / Revised (airflows clarified)
 BSO-M-121 / FLOOR PART PLAN B - LEVEL 2 -MECHANICAL / Revised (airflows clarified)
 BSO-M-401 / SCHEDULES- MECHANICAL / Revised (schedule clarified)

BSO-M-402 / SCHEDULES- MECHANICAL / Revised (schedule clarified)
BSO-M-800 / CONTROLS - MECHANICAL / Revised (controls clarified)
OTV-M-800 / CONTROLS – MECHANICAL / Revised (controls clarified)

SECTION 061719

CROSS-LAMINATED TIMBER CONSTRUCTION

PART 1 – GENERAL

1.1 SUMMARY

- A. Stipulations:
 - 1. The specifications sections “General Conditions to the Construction Contract”, “Special Conditions” and “Division 01 - General Requirements” form a part of this Section by this reference thereto, and shall have the same force and effect as if printed herewith in full.
- B. General: Provide Cross-Laminated Timber Construction in accordance with requirements of the Contract Documents.
- C. Related Work Specified Elsewhere:
 - 1. Section 061800 Glued-Laminated Timber Construction.
 - 2. Section 051200 Structural Steel Framing.

1.2 REFERENCES

- A. General: Comply with the applicable provisions of the referenced standards except as modified by governing codes and the Contract Documents. Where a recommendation or suggestion occurs in the referenced standards, such recommendation or suggestion shall be considered mandatory. In the event of conflict between referenced standards, this specification or within themselves, the more stringent standard or requirement shall govern.
 - 1. American Wood Council (AWC):
 - a. NDS-2018, “National Design Specification for Wood Construction” and supplements.
 - 2. American Institute of Timber Construction (AITC):
 - a. AITC 109-2007, “Standard for Preservative Treatment of Structural Glued Laminated Timber”.
 - 3. The Engineered Wood Association (APA):
 - a. ANSI/APA PRG 320-2012, Standard for Performance Rated Cross-Laminated Timber.
 - b. APA EWS S580D-2013, Technical Note: Preservative Treatment of Glued Laminated Timber.
 - c. APA EWS T300-2007, Technical Note: Glulam Connection Details.
 - 4. ASTM International (ASTM):

- a. ASTM A36/A36M-2019, Standard Specification for Carbon Structural Steel.
 - b. ASTM A276/A276M-2017, Standard Specification for Steel Bars and Shapes.
 - c. ASTM A666-2015, Standard Specification for Annealed or Cold-Worked Austenitic Stainless Steel Sheet, Strip, Plate and Flat Bar.
 - d. ASTM A1011/A1011M-2018a, Standard Specification for Steel Sheet and Strip, Hot-Rolled, Carbon, Structural, High-Strength Low-Alloy, High-Strength Low-Alloy with Improved Formability, and Ultra-High Strength.
5. FPIInnovations (FPI):
- a. SP-529-2013, CLT Handbook, Cross-Laminated Timber (U.S. Edition).
6. American Welding Society (AWS):
- a. AWS D1.1, "Structural Welding Code, Steel".

1.3 DEFINITIONS

- A. Cross-Laminated Limber (CLT): An engineered wood building system used to complement light-and heavy-timber framing options. Layers of lumber are laminated together in alternating directions to form a solid wood panel with high strength and dimensional stability. Typical lay-ups use an odd number of layers, resulting in a primary and secondary structural axis.

1.4 SUBMITTALS

- A. Delegated Design Submittals: Submit for Professional's information. For cross-laminated timber construction indicated to comply with performance requirements and design criteria, including analysis data signed and sealed by the qualified professional engineer responsible for their preparation.
- B. Product Data: Submit for Professional's action. Furnish a material list with technical data documenting the primary function, quality, and performance of each system to be used in the Work, e.g., the lumber stress rating, species, appearance grade, fastener load capacity, connector materials, or other such primary characteristics as required by the Drawings or Specifications. Include the following:
 - 1. Environmental Product Declaration (EPD): For each product.
 - 2. Product Data: For installation adhesives and coatings, indicating VOC content.
 - 3. Chain-of-Custody Certificates: For certified wood products. Include statement of costs.
 - 4. Laboratory Test Reports: For composite wood products, indicating compliance with requirement for low-emitting materials.

- C. Shop Drawings: Submit for Professional's action. Furnish shop drawings for the fabrication and installation of the Work. Show full dimensions of every member and layout of entire structural system. Indicate wood species, appearance grades and stress grades of lumber, and other characteristics of the Work. Include details of connections at a scale not less than 1/2" = 1'-0".
1. Indicate sequence of panel placement.
 2. Indicate screw and attachment locations.
 3. Provide any special handling instructions.
- D. Samples: Submit for Professional's action. Label samples to indicate product, characteristics, and locations in the Work. Samples will be reviewed for color and appearance only. Compliance with all other requirements is the exclusive responsibility of the Contractor. Furnish samples of exposed wood members, representative of the required species, grade, types, and surface treatment. Make samples not less than 12 inches square with 3 laminations and finished with required coating system.
- E. Quality Control Submittals: Submit for Professional's information and Department's Testing Agency's review.
1. Quality Assurance Programs: Furnish details of the fabricator's and the installer's quality assurance programs. Include inspector qualifications, method of reporting, frequency of reporting and distribution of reports. Identify individuals(s) responsible for the program.
- F. Certifications: Submit for Professional's information. Furnish certified reports signed by the fabricator for the following.
1. CLT stress grade and appearance classification.
 2. Lay-up of wood, species, and grades used.
 3. Connection Hardware Standards in accordance with CLT Manufacturer's specifications.
 4. Manufacturer's panel durability tests and testing results. Ensure material tested is typical of a production run of the same material used in the project. Conduct tests on the same production lot(s) for delivery of the panels.
- G. Moisture Protection Method Statement: Submit for Professional's information. Develop and furnish a method statement for field moisture control for review. The moisture protection method statement shall be reviewed during a pre-construction conference no later than one month prior to timber erection.

1.4 QUALITY ASSURANCE

- A. Fabricator / Installer: Cross-laminated timber shall be produced by an active member firm of AITC and/or APA and licensed to apply the AITC and/or APA Quality Mark and who has ten (10) years of experience doing projects similar in scope. Installation shall be performed by the fabricator or by a separate installer approved by the fabricator.

- B. Grade Markings: Grade marks, inspection stamps and other markings shall be applied on surfaces to be concealed from view in the completed Work.
- C. Regulatory Requirements: Comply with applicable requirements of the laws, codes, ordinances and regulations of Federal, State and Municipal authorities having jurisdiction. Obtain necessary approvals from all such authorities.
- D. Structural and Visual Mock-ups:
 - 1. Provide structural and visual mock-ups of the Cross-Laminated Timber Construction, including adjacent materials. Extent as shown on Drawings and representative of the finished work. Provide mock-ups for visual review by the Professional. Provide panel joint conditions and features that will be used in the final Work. Mock-ups shall be erected to sizes agreed to by Professional and Contractor.
 - 2. Replace unsatisfactory Work as required to obtain approval of the Professional. The approved visual mock-ups will become the standard workmanship. The approval of the visual mock-ups does not relieve the Contractor of its obligation to perform the work in accordance with the Contract Documents.

1.5 DELIVERY, STORAGE, AND HANDLING

- A. Deliver the cross-laminated timber to the Project site in covered or protected systems in accordance with manufacturer's standards or recommended instructions for proper handling and storage. Label and deliver in sequence of construction for the Project, equipped with loading straps by the manufacturer, erected by certified crane operators and fabrication handlers and protected for prolonged inclement weather conditions after erected. Replace any damaged or deteriorated panels.
- B. Submit manufacturer's instructions for handling, erection procedures, sequencing, administration of screws and attachments and recommended tools and tolerances. Note applicable safety precautions and standards. Have a copy of all instructions present on the Project site.

PART 2 – PRODUCTS

2.1 CROSS-LAMINATED TIMBER

- A. General: All cross-laminated timber panels shall be fabricated in accordance with ANSI/APA PRG 320. unless otherwise noted in the Drawings.
- B. Lumber: Douglas Fir (Bottom Layer). Provide industry accepted certification showing timber is sustainably sourced and harvested.
- C. Stress Grade: CLT panels must meet minimum effective stress and modulus values stated on the Drawings, graded in accordance with ANSI/APA PRG 320.
- D. Appearance Grade: CLT panels must meet the "Architectural" appearance classification in accordance with ANSI/APA PRG 320. Limit knot holes and voids to 1/2 inch maximum. Fill knot holes and voids. Provide Unit Price for AITC Premium Grade.
- E. Moisture Content: Comply with ANSI/APA PRG 320 for moisture content, up to a maximum of 15 percent, and compatible with the criteria of the certified adhesive applied.
- F. Adhesive: Adhesives must be certified by test for use with the species to which it is applied in accordance with ANSI/APA PRG 320. Apply and allow set times as required by the adhesive

manufacturer's instructions. Also, apply pressure on the panels and for the duration during manufacture as required by the adhesive manufacturer's instructions.

- G. ~~Fire Retardant Treatment: Pressure impregnate fire-retardant treated wood with an approved process for the location in accordance with AITC 109 or APA EWS S580D, AWPA T1, and AWPA U1. Any strength or stiffness reduction due to treatment must be provided by the treater. Kiln dry all wood after treatment to remove the moisture added during treatment. Moisture content throughout material after drying must be less than 15 percent.~~

2.2 ANCHORS, FASTENERS AND HARDWARE

- A. Fasteners: Provide the fastenings necessary for secure installation of the Work. Types and sizes as best suited for each application.
- B. Custom Anchors and Connectors: Design connections to AWC NDS, and AISC 360, to resist shears, moments and forces indicated. Fabricate connective hardware in accordance with AISC 360.
- C. Structural Steel: Provide structural steel shapes, plates, and flat bars as indicated for assembly and connection of members conforming to ASTM A36/A36M.
- D. Hot-Rolled Steel Sheet: Provide hot-rolled steel sheet complying with ASTM A1011/A1011M, structural steel, Type SS, Grade 33.
- E. Stainless Steel:
 - 1. Provide stainless steel bars and shapes complying with ASTM A276/A276M Type 316.
 - 2. Provide stainless steel plate, flat bars, and sheets complying with ASTM A666 Type 316.

2.3 FABRICATION

- A. Fabrication Tolerances: Comply with requirements of ANSI/APA PRG 320-2012.

2.4 WOOD FINISHES

- A. Translucent Stain Wood Finish System (Pigment, Satin): Apply in accordance with manufacturer's recommendations. Manufacturer's standard stain finish system designed for protection of panels consisting of the following:
 - 1. Shop-Applied Translucent Basecoat: (1 Coat).
 - a. Sansin "KP-12UVW"
 - 2. Shop-Applied Translucent Top Coat: (2 Coats applied per Manufacturer's Direction).
 - a. Sansin "Purity Glacier"- Low Lustre

PART 3 – EXECUTION

3.1 GENERAL

- A. Manufacturer's Instructions: Prepare substrates and install the work of this Section, including, components and accessories in accordance with the manufacturer's instructions, except where more stringent requirements are shown or specified, and where project conditions require extra precautions or provisions to ensure satisfactory performance of the Work.

3.2 EXAMINATION

- A. Verification of Conditions: Examine the areas to receive the Work and the conditions under which the Work would be performed. Contractor shall remedy conditions detrimental to the proper and timely completion of the Work. Do not proceed until unsatisfactory conditions have been corrected. Survey of related existing construction to be submitted to Professionals for review with related shop drawings prior to shipping of work.
- B. Verify that cross-laminated timber panels may be erected in strict accordance with all referenced standards, the original design, and the Shop Drawings.
- C. In the event of discrepancy, immediately notify the Professionals.
- D. Do not proceed with installation in areas of discrepancy until all such discrepancies have been fully resolved.

3.2 INSTALLATION

- A. General: Provide in accordance with reviewed shop drawings and installation procedures. Set Work accurately to required lines and levels, members plumb and true, accurately fitted and securely connected. Field repair or modification of members is not permitted without written approval of the manufacturer. Provide erection bracing in addition to required blocking or bridging as necessary to keep panels straight and plumb with adequate lateral support for the entire system until permanent bracing has been installed. Stresses beyond design limits are not permitted, including temporary construction loads.
- B. Installation: Conform to spacing and placement of panels and installation methods in accordance with the manufacturer's instruction and APA EWS T300.
 - 1. Provide close fits and neat appearance of joints without binding or adding additional stresses to the panel.
 - 2. Hoist panels in place in accordance with the manufacturer's instructions using non-marring straps and connectors.
 - 3. Brace erected member so as to maintain a safe working environment and stable structure.
 - 4. Avoid on-site cuts; however, if necessary, only with the approval of the Professional, except for fastener drilling and other minor cutting. Coat all cuts and inside surfaces of drilled holes with end sealer.
- C. Erection Tolerances: Provide as indicated and within the following permissible deviations. Compensate for daily temperature variations, construction loadings, sequential applications of permanent dead loads, or any other predictable conditions that could cause distortions to exceed tolerance limitations.
- D. Coordination: Schedule and coordinate the Work with other trades. Furnish anchors, fastenings and other miscellaneous items required for securing to other construction.
- E. Protection from Weather: Provide waterproof protective coverings for cross-laminated timber panels after installation and before building is enclosed.
- F. Wood Finish System, Top Coat: Field application when the building is open in strict accordance with manufacturer's written instructions.

3.3 FIELD QUALITY CONTROL

- A. Surveys: Survey the final erected structure prior to the application of any other work, reporting any discrepancies from Contract requirements to the Professional.

3.4 CONTRACTOR'S MONITORING ACTIVITIES

- A. Testing Agency: Contractor's testing agency to perform field monitoring activities in accordance with the Contractor's approved Quality Control Program.

3.5 CLEANING

- A. Upon completion of the cross-laminated timber Work, remove unused materials, debris, containers and equipment from the project site.

3.6 DEPARTMENT'S QUALITY ASSURANCE SERVICES

- A. Quality Assurance Services: Independent Testing and Inspection Agency(ies), engaged at the Department's expense through the Professional, will perform the following activities to monitor the Contractor's Quality Control Services. The Department's Quality Assurance Services monitoring of activities do not relieve the Contractor of responsibilities under the Contract.
- A. Visual Inspection of Cross-Laminated Timber Installation: Perform inspection of the field erection to verify compliance with the specification and the Contractor's erection procedures.
- B. Special Inspections: Perform special inspections as required per applicable building codes and standards during shop fabrication and field installation.

END OF SECTION



Pennsylvania State Police Academy & BESO Modernization

Pre-Bid Meeting - 16 June 2023

SOM

Department of General Service
Pennsylvania State Police

Agenda

10:00 AM **Introduction & Sign In**

10:05 AM **Welcome to the Academy (Maj. Cawley)**

10:25 AM **Project Information**

10:35 AM **Meeting Purpose**

10:40 AM **BDISBO**

11:10 AM **Bid Requirements**

11:30 AM **Technical Requirements**

12:00 PM **Special Conditions**

12:15 PM **Construction Administration**

12:45 PM **Questions & Answers**

1:00 PM **Project Walk Through**

Reminders

All proposers should SIGN IN.

Attendance is strongly suggested but not mandatory.

All bidder questions must be submitted through E-Builder under the Questions/Responses tab.

Verbal responses are non-binding. Only written formal responses in the form of an official project Addendum are to be used for bidding purposes.

NO Photos!

Deadline to submit questions is July 18, 2023 @ 5pm.

Proposals are due August 1, 2023 @ 2pm.

The Project timeline does not include the opportunity for DGS to extend the bid. All bidders should plan their time accordingly.

Introduction

Project Team

Pennsylvania DGS

Lisa Dorman

Hans Baker

Bill Hess, PC

Danay Vargas, PC

Steve Bernadyn, PC

David Hyde, APC

Karl Howerter, APC

Tim Evans, APC

Joe Alfano, APC

Pennsylvania State Police Academy

Major Cawley

Marc Infantino

Lte Troutman



SOM (Architecture & Structural Engineering)

Nate Broughton

Langan (Civil Engineering)

Kyle Fink

A&J Engineering (E/P/FP)

Harshal Shah

Interface Engineering (M)

Stephen Tarbuck



SOM

Project Information

Project Location

Pennsylvania State Police Academy
175 Hersheypark Drive
Hershey, PA 17033

County : Dauphin County

Local Municipality : Derry Township



Project Information

Bid Date:	May 25, 2023	Base Bids:	None
Contracts:	.1 General Contract .2 Mechanical Contract .3 Plumbing Contract .4 Electrical Contract	E-builder Contact:	Susan Stanisic (sstanisic@pa.gov, 717-783-3273)
Bid Type:	Best Value	Project Description:	The project consists of Modernization of the PSP Academy & BESO to accommodate modern law enforcement training.
Bid Guaranty:	None		
Construction Duration:	1642 Calendar Days		
Proposal Period:	90 days from Bid Opening to Award of Contract		

Meeting Purpose

- Conduct a discussion of the bid requirements to assist the bidders in understanding DGS' bidding procedures required for preparation of their proposals.
- Conduct a discussion of the project technical requirements
- Conduct a review of the Special Project restrictions.
- Conduct a review to the Construction Administration procedure requirements
- Conduct a project walk thru.
- Allow the bidders to ask bid and project related questions



© Skidmore, Owings & Merrill
Renderings are representational and for reference only.

BDISBO

Bid Requirements

Bid Schedule

- Issue Bid Documents: May 25, 2023
- Pre-bid Meeting: June 16, 2023
- Deadline to Submit Questions: **July 18, 2023 at 5pm**
- Deadline to Issue Addendums: July 25, 2023
- Bids Due: **August 1, 2023 at 2pm**

The Project timeline does not include the opportunity for DGS to extend the bid. All bidders should plan their time accordingly.

Bid Requirements & Separations Act

- **All bids to be hand delivered or via courier.**
- **Bid Forms are all through E-Builder.**
- **Separations Act - 4 Contracts**
 - .1 General Contractor
 - .2 Mechanical Contractor
 - .3 Plumbing Contractor
 - .4 Electrical Contractor

Technical Requirements

Drawing Review

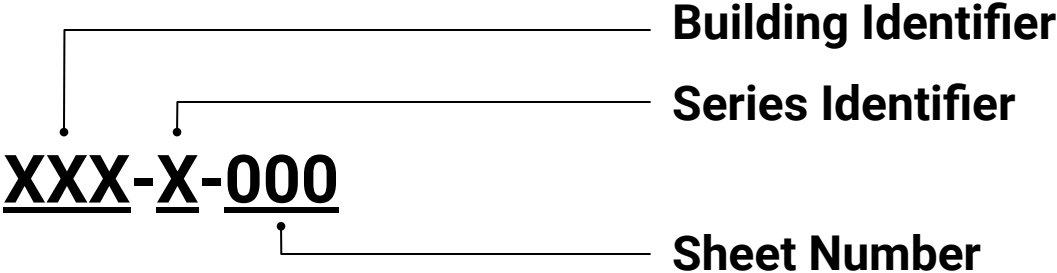

Series Identifier

G	General Set Information
LS	Life Safety
VT	Existing Features
C	Civil
H	HazMat
L	Landscape
I	Irrigation
AX	Architecture Demo
MX	Mechanical Demo
PX	Plumbing Demo
FX	Fire Protection Demo
EX	Electrical Demo
A	Architecture
S	Structures
QF	Food Service
SP	Pool Design
RM	Radon Mitigation
M	Mechanical
P	Plumbing
F	Fire Protection
E	Electrical
TC	Telecommunications
AV	Audiovisual
Y	Security

Building Identifier

GEN	General Set Information
MAQ	Marquee
ITV	Indoor Tactical Village
GYM	Physical Education
FTU	Indoor Firearms Range
BSO	Bureau of Emergency & Special Operations (BESO)
ATO	Automotive / Buildings & Grounds (NIC)
P&S	Procurement & Supply Warehouse (NIC)
STA	Stables & Supporting Facilities (NIC)
GRG	Museum Garage
OTV	Outdoor Training Village (NIC)
COV	Callout Training Village (NIC)





© Skidmore, Owings & Merrill
Renderings are representational and for reference only.

SKIDMORE, OWINGS & MERRILL LLP



LE THAT THE HONOR OF THE FORCE...

ENTRUSTED THE HONOR OF THE FORCE. I MUST SERVE HONESTLY, FAITHFULLY, AND...

...RATHER THAN SWERVE FROM THE PATH OF DUTY. IT IS MY DUTY TO OBEY THE LAW AND TO ENFORCE IT WI

...RATHER THAN SWERVE FROM THE PATH OF DUTY. IT IS MY DUTY TO OBEY THE LAW AND TO ENFORCE IT WI







© Skidmore, Owings & Merrill
Renderings are representational and for reference only.

Permits

- **NPDES Permit for Stormwater Management and E&S Control**
 - Refer to Civil Plans for Permit Requirements - Kick-off meeting required before earth moving activities.
 - Contractor will be a co-permittee on NPDES Permit
- **All 33 Building Permits have been issued - Individual permits for every structure**
 - Marquee
 - Gym
 - Firearms Building
 - BESO
 - Museum Garage

Special Conditions

Site Phasing & Operations

- **Academy Operations**

- Academy Operations will be continue throughout construction and will involve program relocation as construction of new buildings is completed.
- Protect existing utilities and facilities throughout the project except where otherwise noted. Identification and protection of existing utilities is critical and will require detailed coordination.
- Provide adequate parking for ongoing Academy operations. To be coordinated with Department. Contractor will provide designated parking for construction activities as needed. Temporary parking solutions should be considered for both cases.
- Installation and maintenance of a temporary chain link fence with entrance gates as required to properly and safely secure the operation in accordance with federal, state and local requirements.

Site Phasing & Operations

- **Site Requirements**

- Installation and maintenance of site roadway construction signage and associated traffic measures
- Designated Truck Route from North Drive to Laudermilch Road along Swatara Road.
- Removal/abandonment of existing above-ground and underground utilities and associated structures. Accurately locate all facilities and to determine their extent. Coordinate with ongoing Academy operations and certify that utilities have been disconnected prior to demolition.

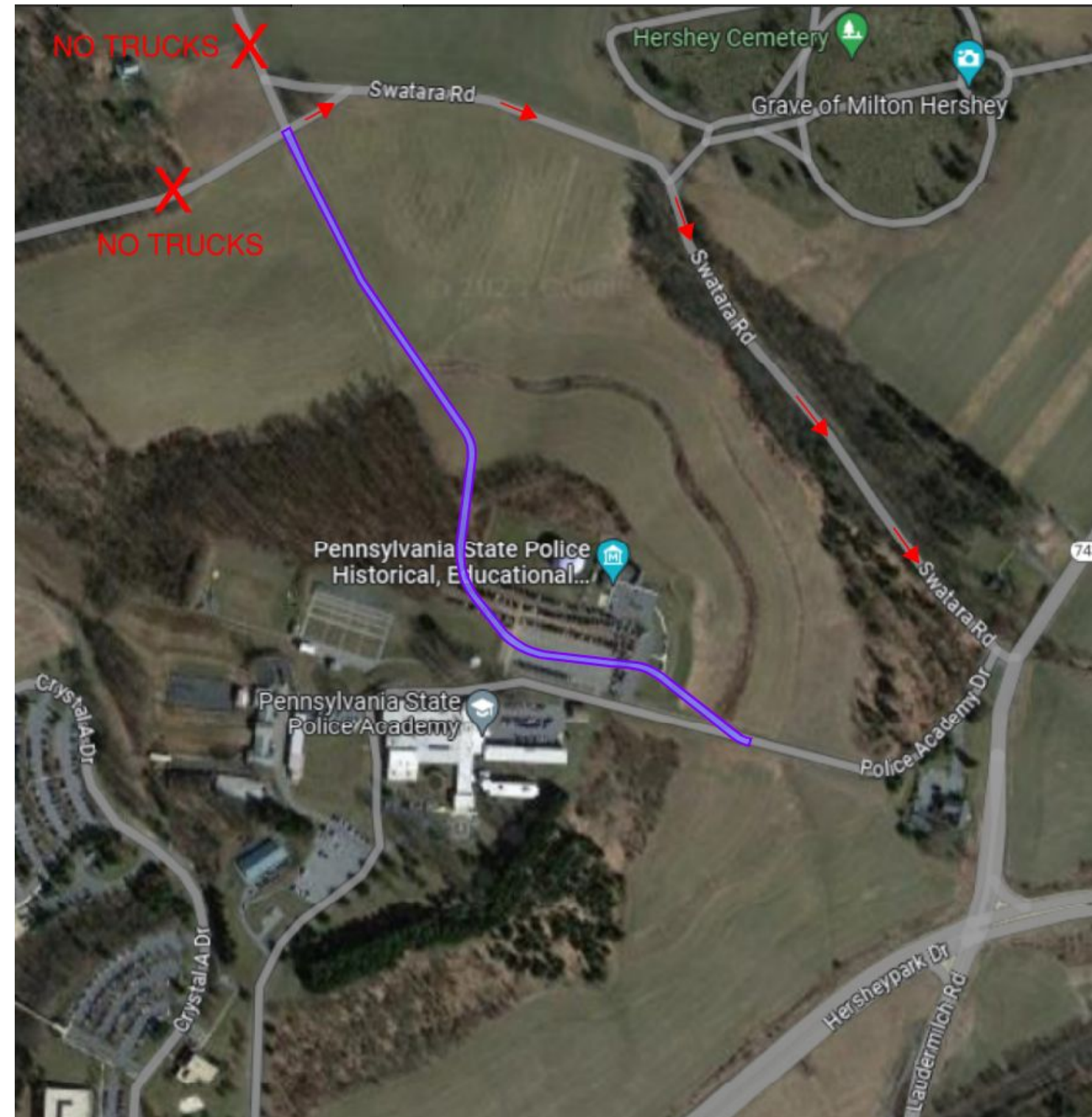

Site Phasing & Operations

- **Grading and Earthwork**
 - Installation and maintenance of soil erosion and sediment control measures.
 - All areas disturbed by contractor must be protected by perimeter controls as required to protect downstream areas. Additional coordination at contract limits will be required.
 - Installation and maintenance of site roadway construction signage and associated traffic measures
 - Protection of existing structures, trees, or vegetation to remain.
 - Protection of Stormwater Management basin bottoms from compaction and loss of infiltration capabilities.
 - Contractor to provide earthwork and grading necessary for the construction of contract site improvements. Will involve coordination and temporary conditions along contract boundary.
 - Contractor to stockpile 20,000 CY of export as suitable material to be used for adjacent contract. Stockpile location shown on plans.

Project Sequencing

Design team approached the project sequencing based on accessibility and constraints of individual building construction.

- Contractor responsible for Means & Methods
- Critical pathway should be considered at all times.

SEQUENCE 1

- Demo of Admin Wing & Shoot House
- Installation of Construction Logistics/Haul Road
- Construction of MAQ & Gym
- Demo of existing Academy building
- Construction of Indoor Firearms Range

SEQUENCE 2

- Construction of Stables (NIC)
- Demo of existing Stables
- Construction of Auto/B&G (NIC)
- Demo of Kennels
- Construction of BESO
- Demo of existing facilities buildings
- Demo of Garage and Existing BESO
- Construction of OTV (NIC)
- Demolition of Water Tower

Independent Items

- P & S Warehouse & Support Buildings (NIC)
- Museum Garage
- Callout Village (NIC)
- Riding Ring

Contract Limits

20,000 CY EXPORT STOCKPILE AREA (PART OF CONTRACT)

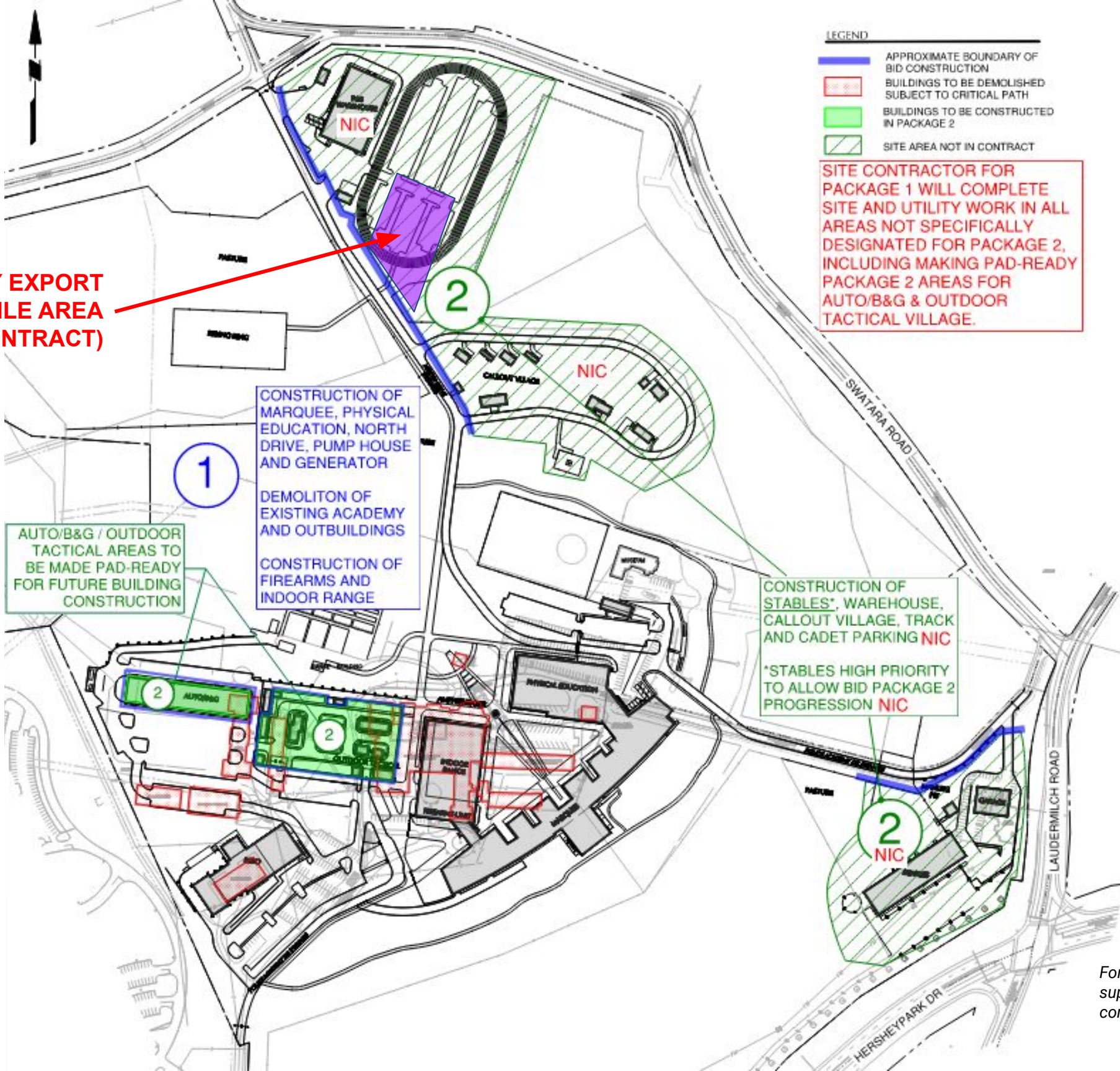







For reference only. Diagrams do not supersede information contained in the contract documents.

Project Sequencing

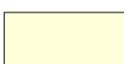

For reference only. Diagrams do not supersede information contained in the contract documents.





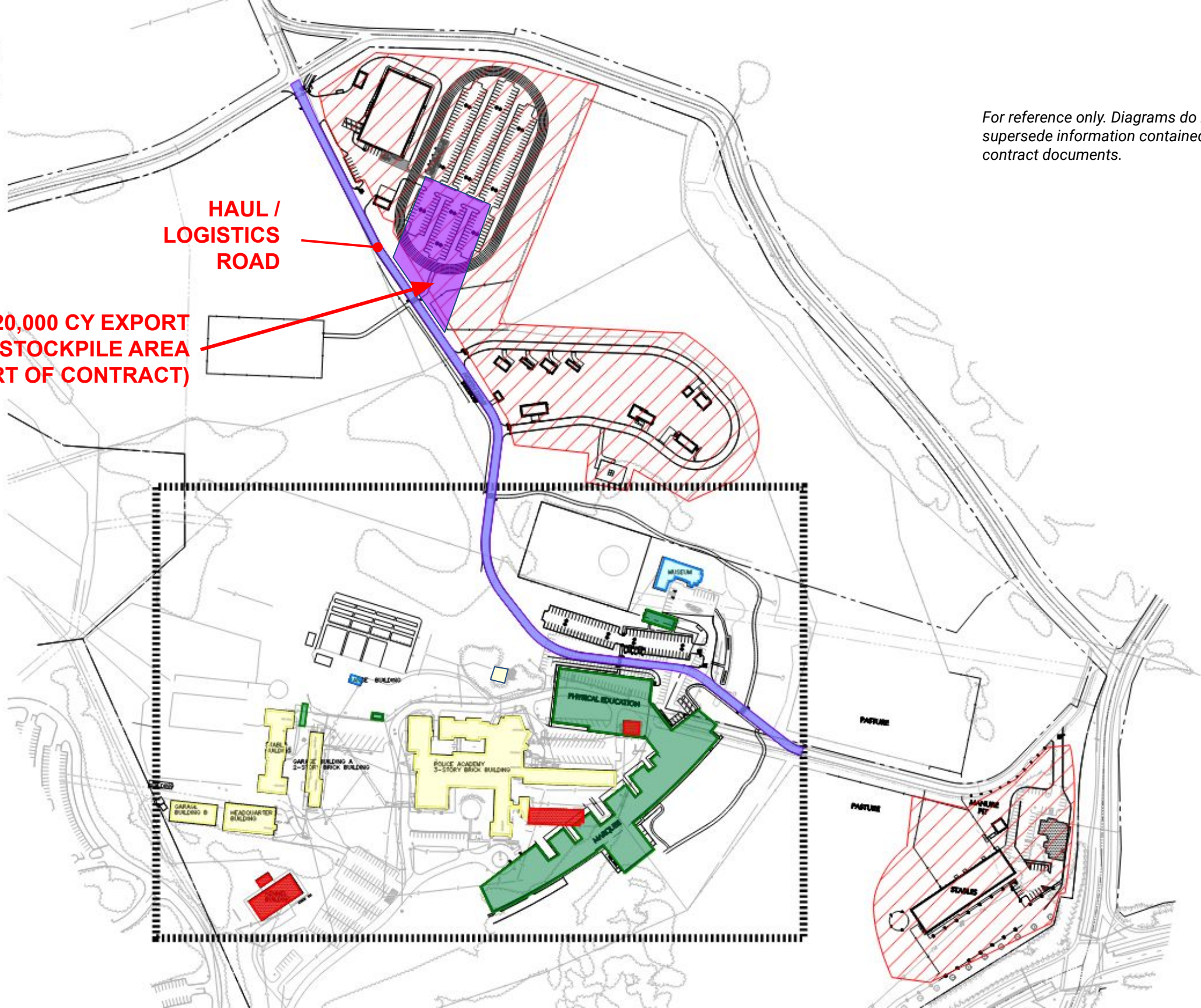

-  NOT IN CONTRACT
-  BUILDING TO REMAIN
-  PROPOSED BUILDING
-  DEMOLISHED BUILDING
-  BUILDING TO BE DEMOLISHED LATER IN SEQUENCE
-  AREA TO BE MADE PAD-READY FOR BUILDING UNDER SEERERATE CONTRACE
-  CONSTRUCTED BUILDING

HAUL / LOGISTICS ROAD

20,000 CY EXPORT STOCKPILE AREA (PART OF CONTRACT)



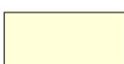



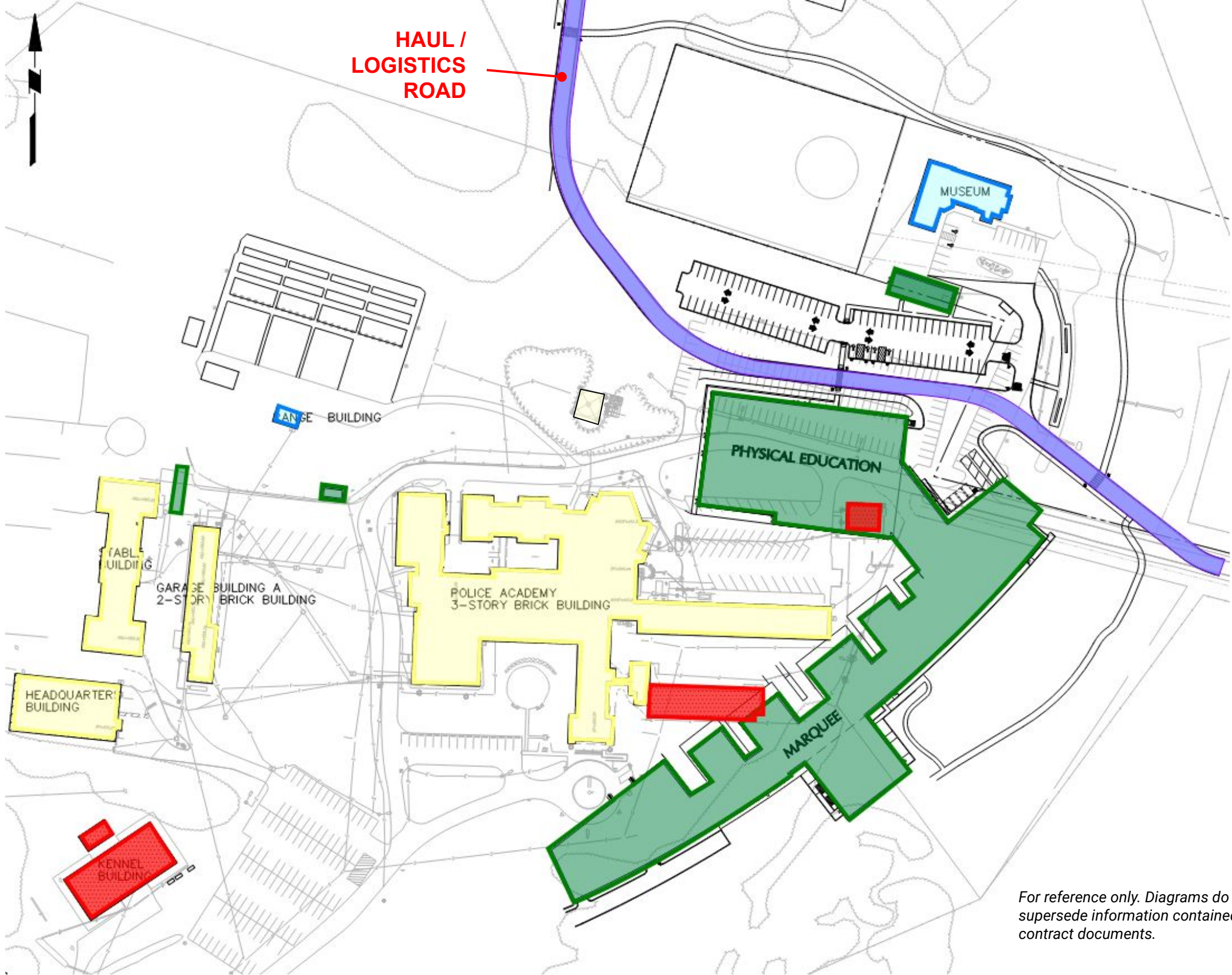

Project Sequencing

-  NOT IN CONTRACT
-  BUILDING TO REMAIN
-  PROPOSED BUILDING
-  DEMOLISHED BUILDING
-  BUILDING TO BE DEMOLISHED LATER IN SEQUENCE
-  AREA TO BE MADE PAD-READY FOR BUILDING UNDER SEPARATE CONTRACT
-  CONSTRUCTED BUILDING



For reference only. Diagrams do not supersede information contained in the contract documents.

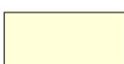



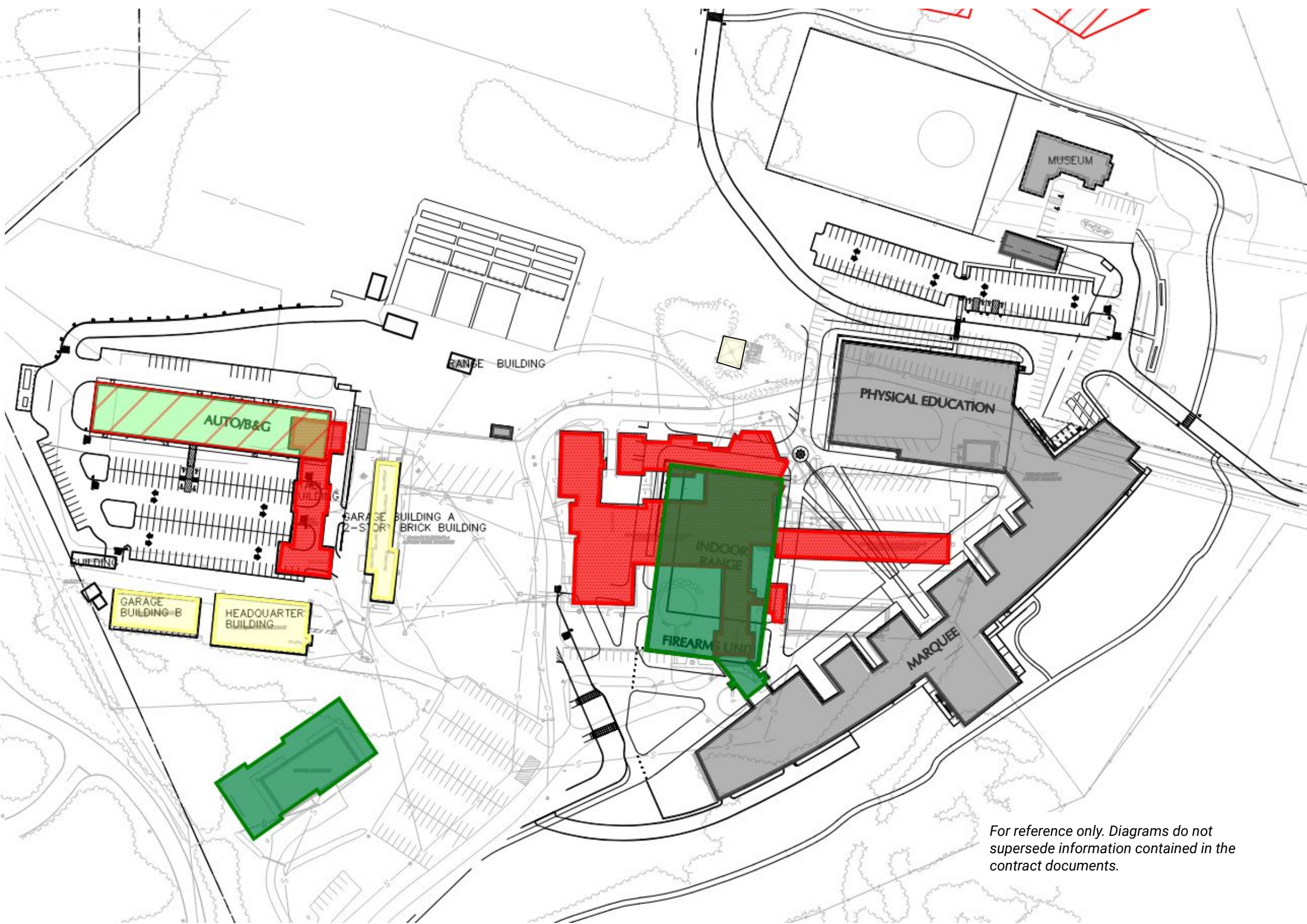

Project Sequencing

-  NOT IN CONTRACT
-  BUILDING TO REMAIN
-  PROPOSED BUILDING
-  DEMOLISHED BUILDING
-  BUILDING TO BE DEMOLISHED LATER IN SEQUENCE
-  AREA TO BE MADE PAD-READY FOR BUILDING UNDER SEPERATE CONTRACE
-  CONSTRUCTED BUILDING



For reference only. Diagrams do not supersede information contained in the contract documents.

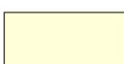



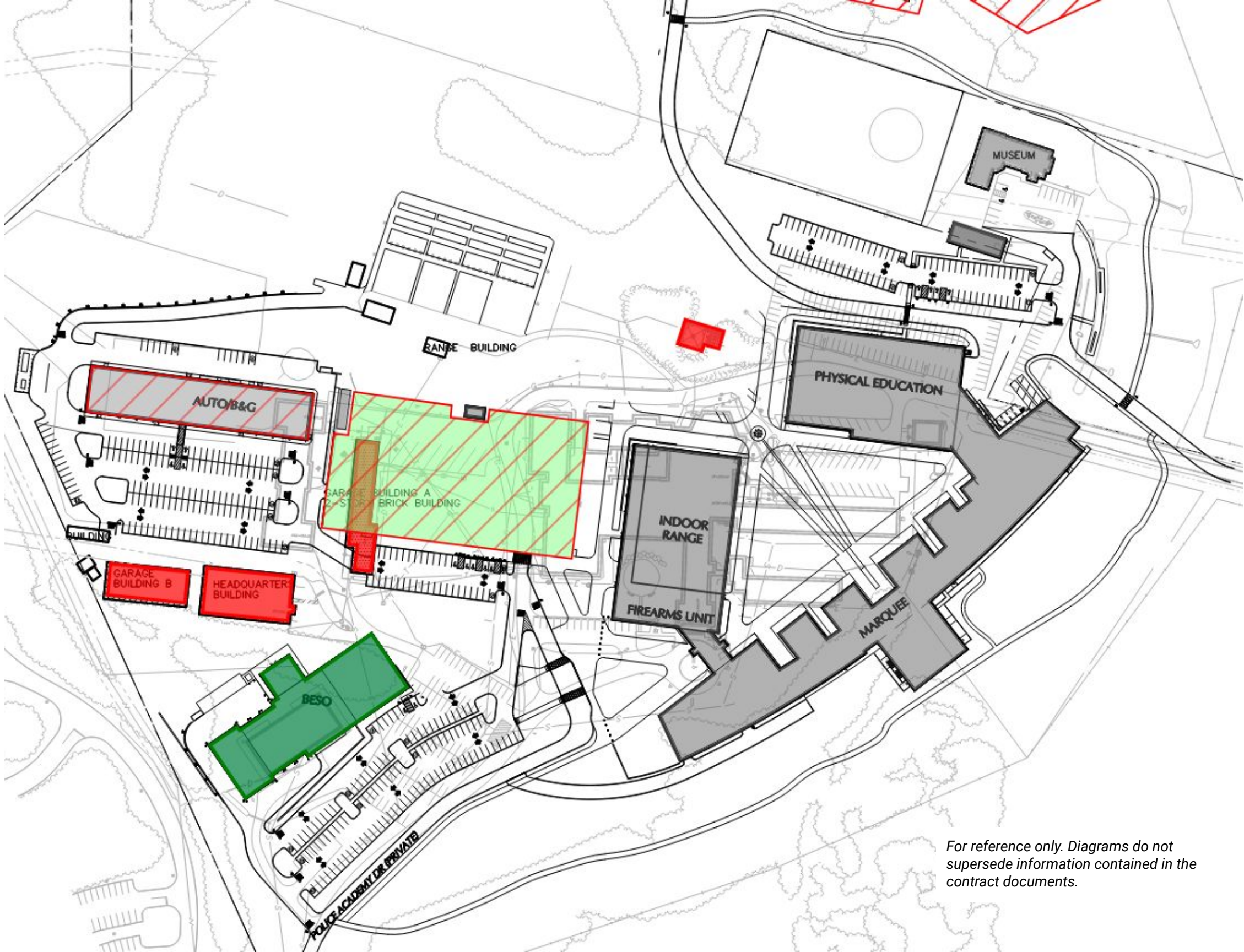

Project Sequencing

-  NOT IN CONTRACT
-  BUILDING TO REMAIN
-  PROPOSED BUILDING
-  DEMOLISHED BUILDING
-  BUILDING TO BE DEMOLISHED LATER IN SEQUENCE
-  AREA TO BE MADE PAD-READY FOR BUILDING UNDER SEPERATE CONTRACE
-  CONSTRUCTED BUILDING

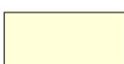

For reference only. Diagrams do not supersede information contained in the contract documents.

Project Sequencing

-  NOT IN CONTRACT
-  BUILDING TO REMAIN
-  PROPOSED BUILDING
-  DEMOLISHED BUILDING
-  BUILDING TO BE DEMOLISHED LATER IN SEQUENCE
-  AREA TO BE MADE PAD-READY FOR BUILDING UNDER SEPERATE CONTRACE
-  CONSTRUCTED BUILDING

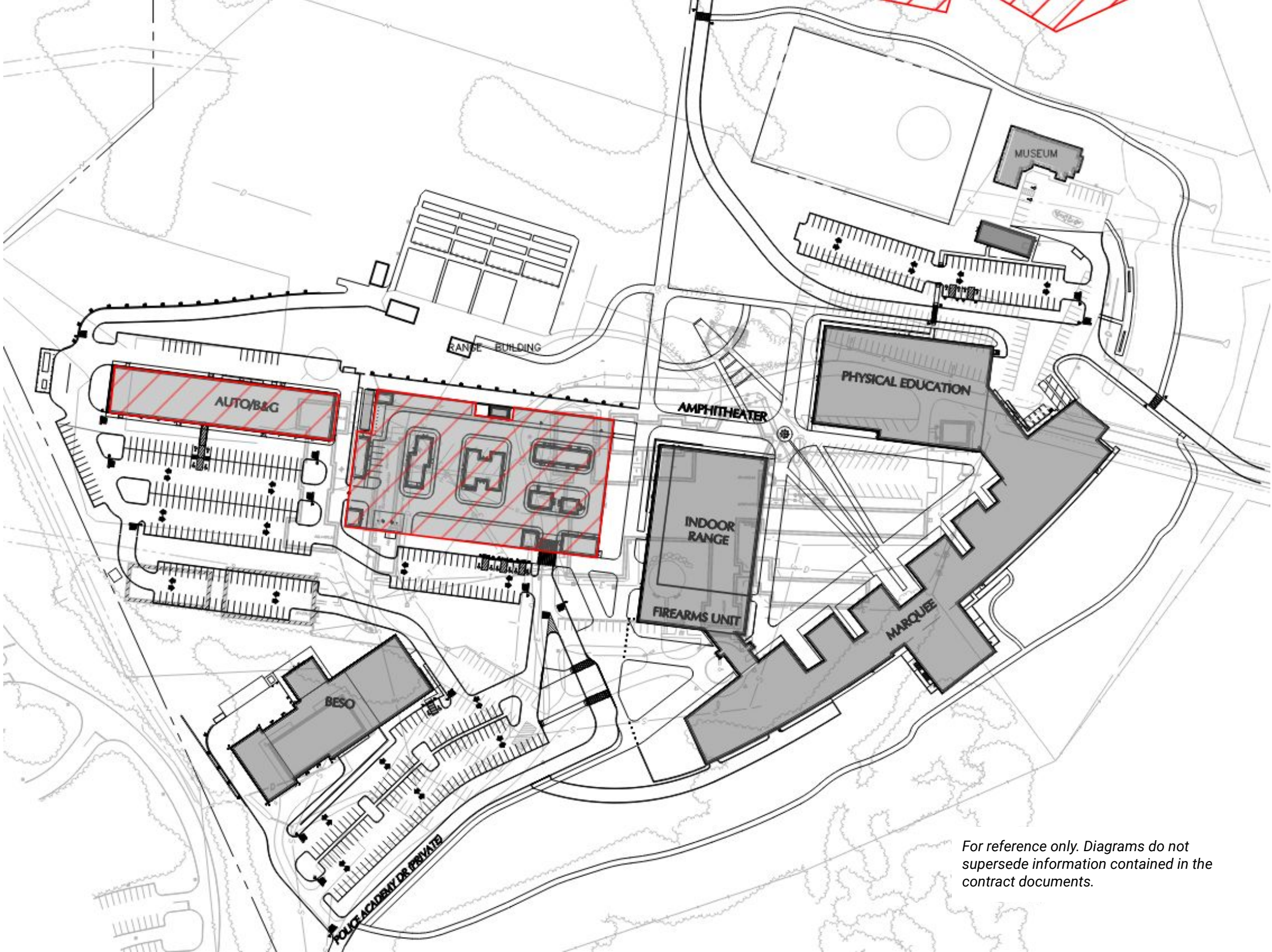

For reference only. Diagrams do not supersede information contained in the contract documents.

Exposed Mass Timber Elements

- Delivery, handling, and storage
- Moisture content control
- Protection of architectural exposed faces



CLT/Steel Coordination

- Close coordination required between CLT and steel elements.
 - Steel Connection Detailing
 - CLT edge detailing

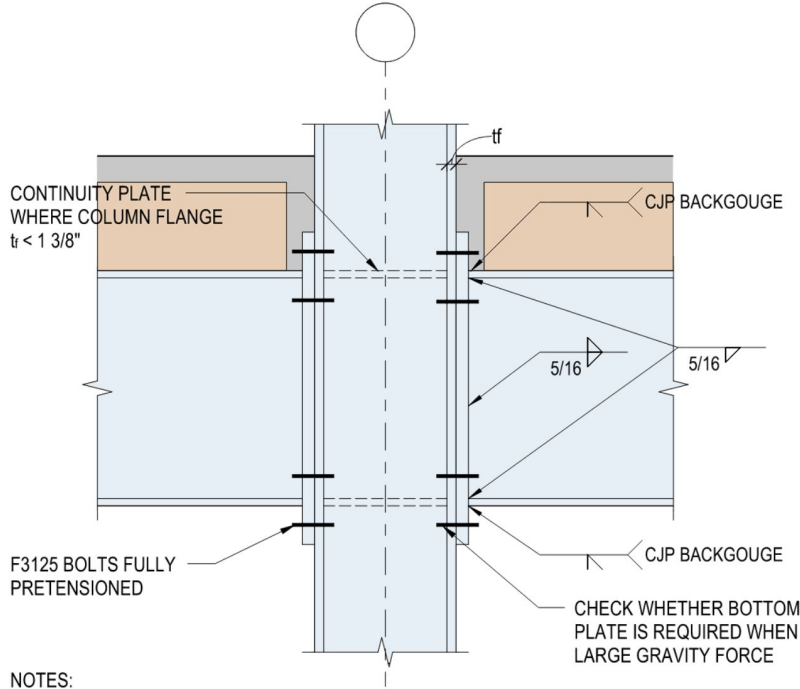

NOTES:

1. CONNECTION TO DEVELOP THE SCHEDULED MOMENT PLUS THE SCHEDULED SHEAR REACTION.
2. CONTINUITY PLATE TO WEB WELD TO DEVELOP 1/2 THE SMALLER SCHEDULED MOMENT.

10 TYPICAL BEAM TO COLUMN END PLATE MOMENT CONNECTION (AT LEVEL 3 - ROOF PERIMETER MOMENT FRAMES)

SCALE: NOT TO SCALE

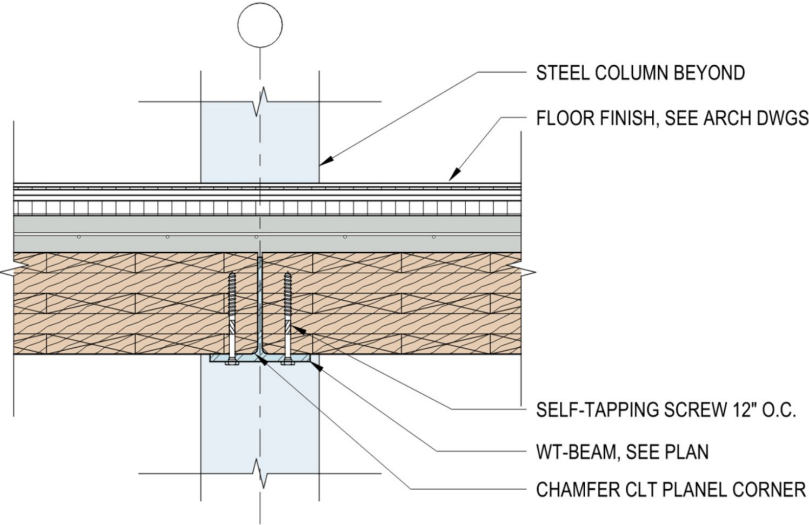

3 TYPICAL CLT PANNEL SPLICE CONNECTION AT WT
1 1/2" = 1'-0"

CLT Layout

- CLT panels to be prefabricated with openings for:
 - Shear studs
 - Curtain wall embed
 - MEP openings
- Close coordination required with adjacent trades
- Detailed layout submission required similar to metal deck shop drawings

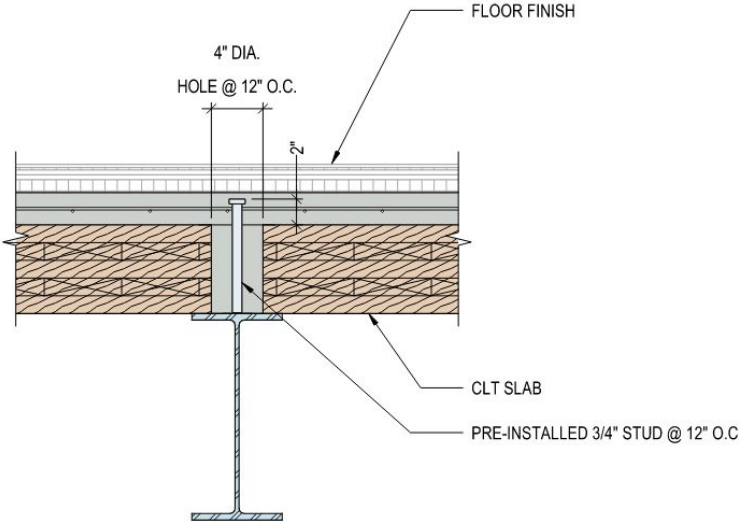

5 TYPICAL CLT PANEL AT STEEL BEAM
1 1/2" = 1'-0"

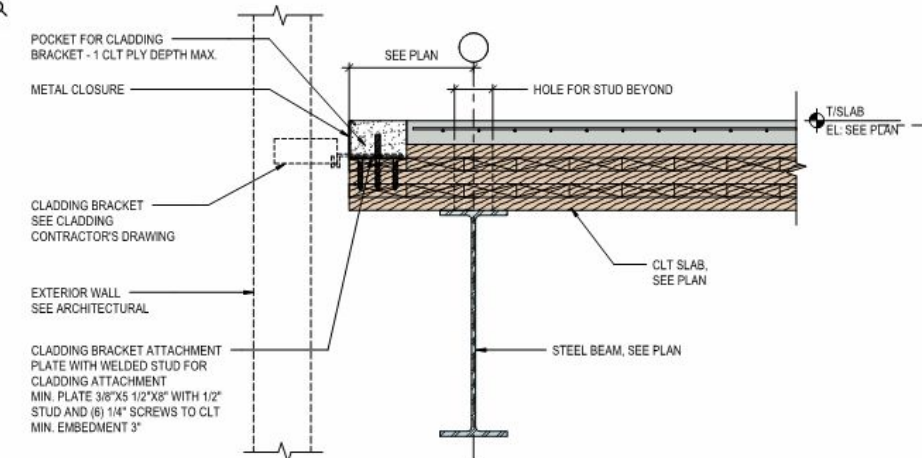
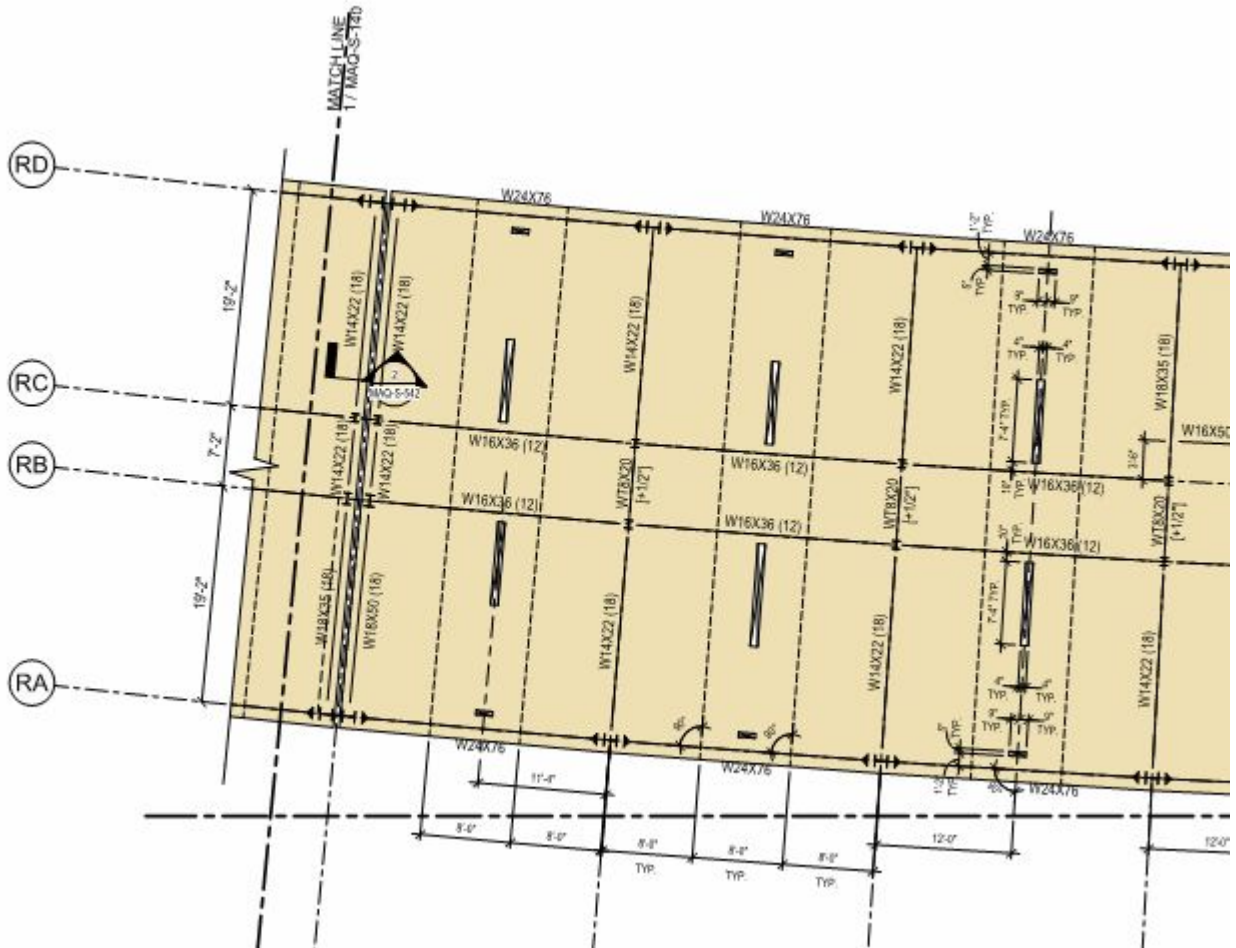

- NOTES:
1. COORDINATE SIZE AND LOCATION OF POCKET WITH CLADDING CONTRACTOR.
 2. COORDINATE ATTACHMENT PLATE SIZE, THICKNESS AND SCREW SIZES AND LOCATIONS WITH CLADDING CONTRACTOR.
 3. FIELD INSTALL ATTACHMENT PLATE AT POSITIONS LOCATED BY CLADDING CONTRACTOR.

7 TYPICAL SLAB EDGE AT CLADDING CONNECTION
NOT TO SCALE

Excavation & Stability

- Sloped site with different retaining strategies at different buildings. Closely consider excavation sequencing and stability requirements

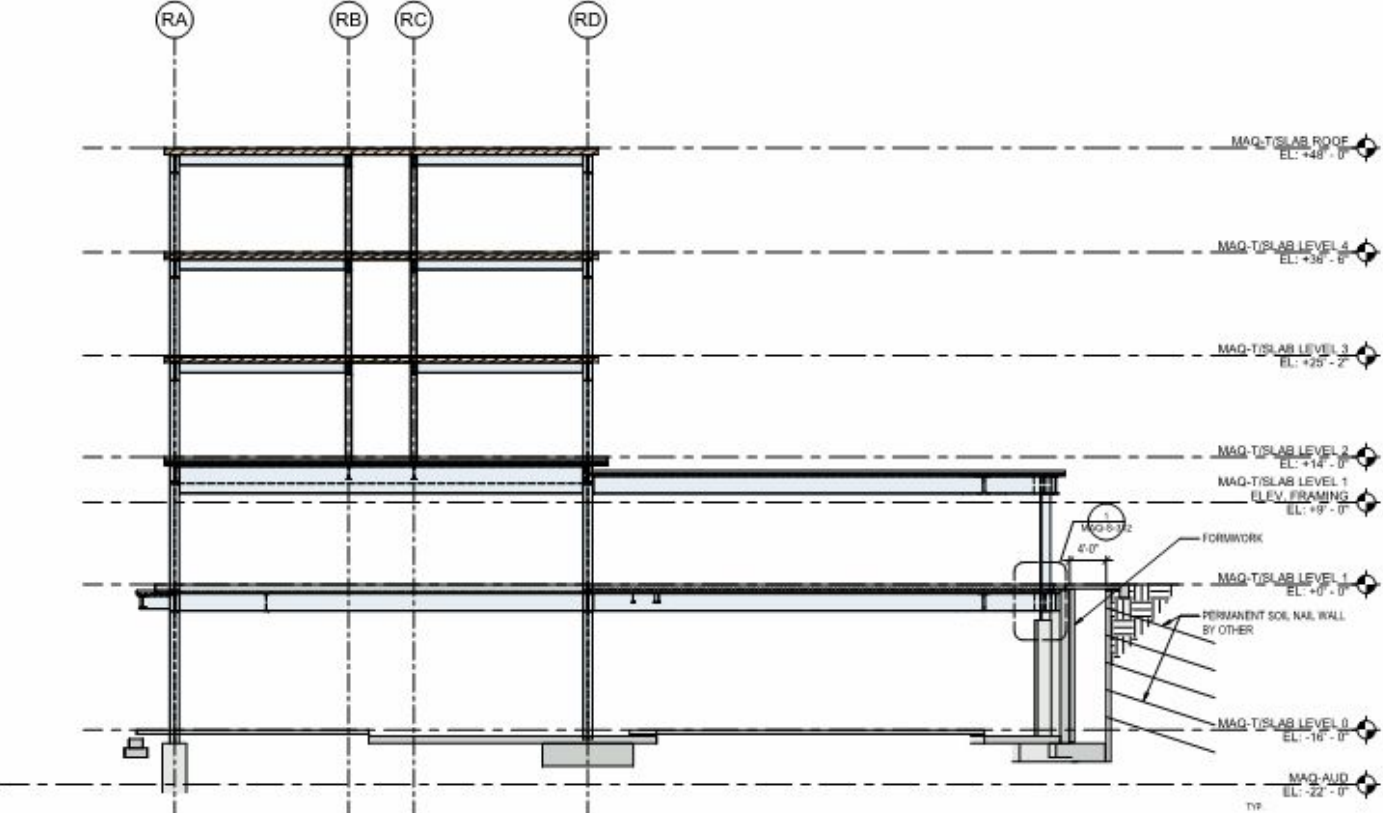

2 BUILDING SECTION - GRID R7
1/8" = 1'-0"

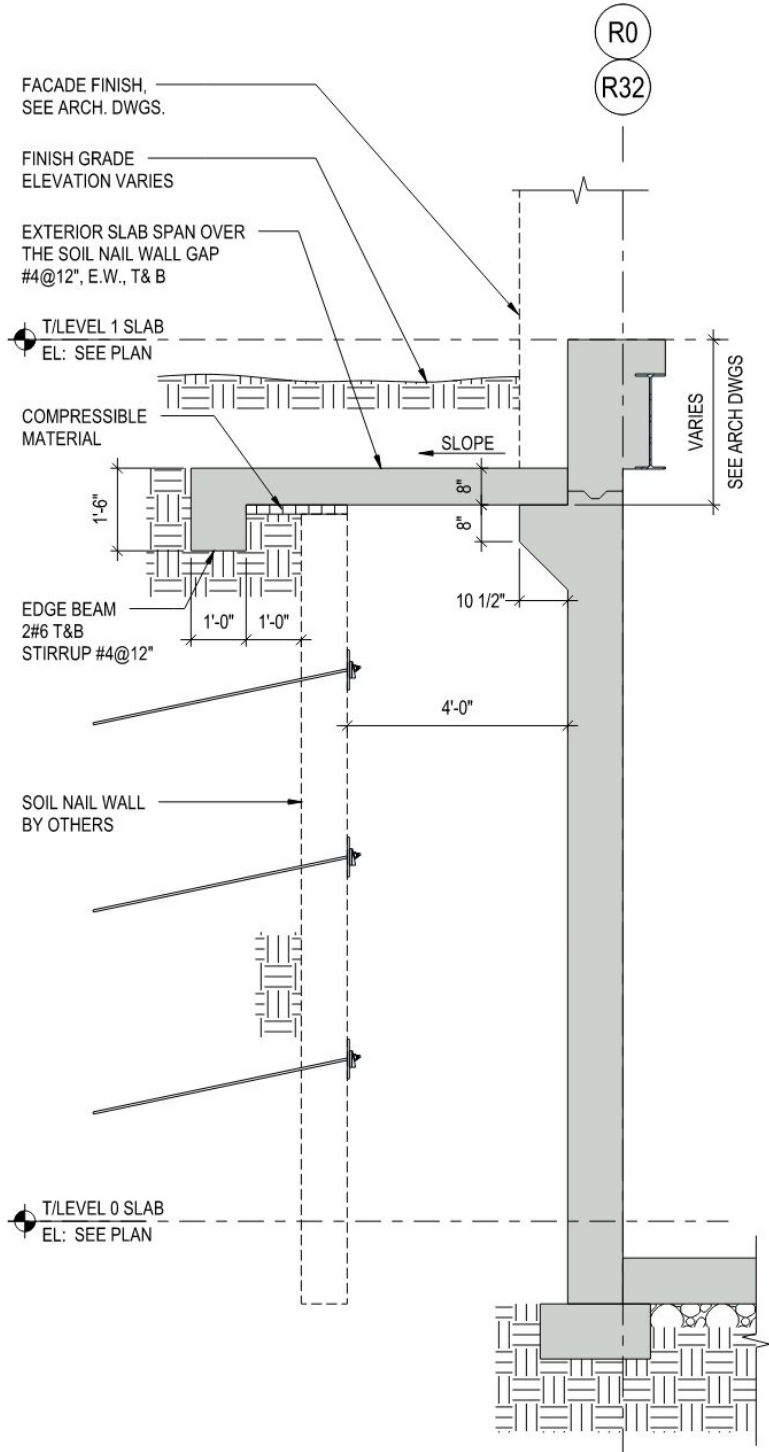

1 WALL SECTION 1-1
SCALE: 1/2" = 1'-0"

Construction Administration

Construction Administration Procedures

- Working Hours: **Monday - Friday, 7am -5pm**
- Project Duration: **1642 Calendar Days**
- Project Schedule: **Refer to Spec Section 013110 (Dates are for information only. Final milestones dates will be agreed upon between DGS and the 4 prime contractors in concert with the prime contractors for Package 2.)**
- Coordination: **The contractors will have a duty to coordinate with the department and the prime contractors working separately on the site via package 2 under a separate contract.**
- Known Academy Events: **Graduation Ceremony (2x a year), Promotion Ceremonies**
- Temporary Utilities to Trailers
- Temporary Utilities to Facility
- Construction impacts to the Client Agency: **The Academy will remain active throughout construction and must be notified of any utility outages or interruptions.**
- Hot Work Permits
- Fire Alarms
- Any danger of invalidating warranties on existing installed materials or equipment
- Any anticipated change orders
- Removal and replacement of existing furniture, fixtures, and equipment: **PSPA (to confirm)**
- Weather Delays and adverse weather policies: **Normal weather for Hershey, PA will not be a reason for an extension of time.**
- Hazardous materials (asbestos, lead)

Contract Limits

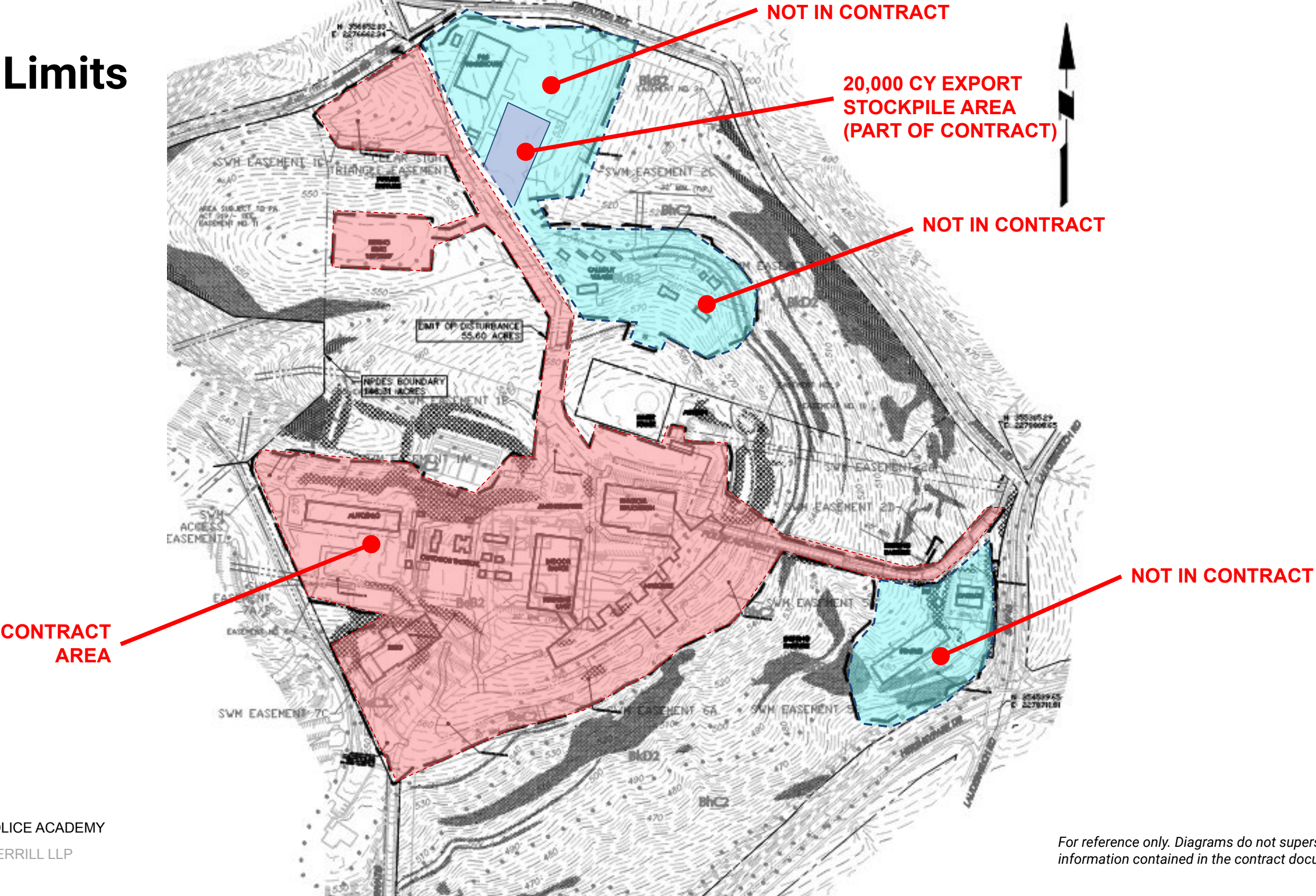

Do Not Disturb Areas

-Refer to Civil Drawings for Limit of Disturbance Boundary

- 55.6 Acres of 146.3 Acre Site

-PA American Water owned Property in center of site.

-Steep slopes & wooded areas outside of the Limits of Disturbance are not to be disturbed.

-Outdoor Firing Range and Adjacent Open Space

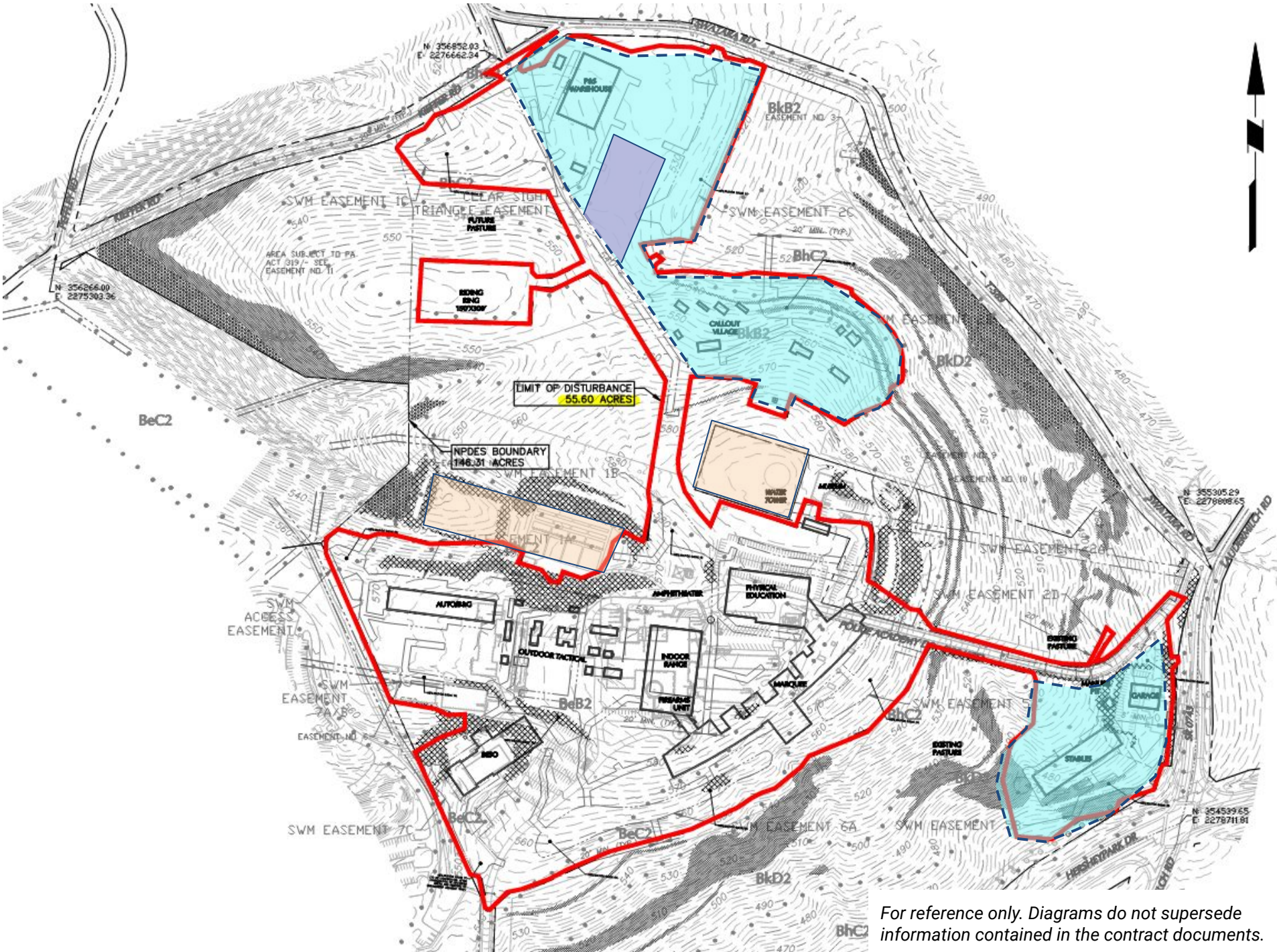

For reference only. Diagrams do not supersede information contained in the contract documents.

Constructions Logistics & Access

Existing Conditions -> Marquee

- Utilizes existing parking areas & open lawn space.
- Coordinate use of space with PSPA to minimize program and construction interruption.
- Parking areas, haul routes, and staging areas will adjust based on project phasing, contractor means and methods.

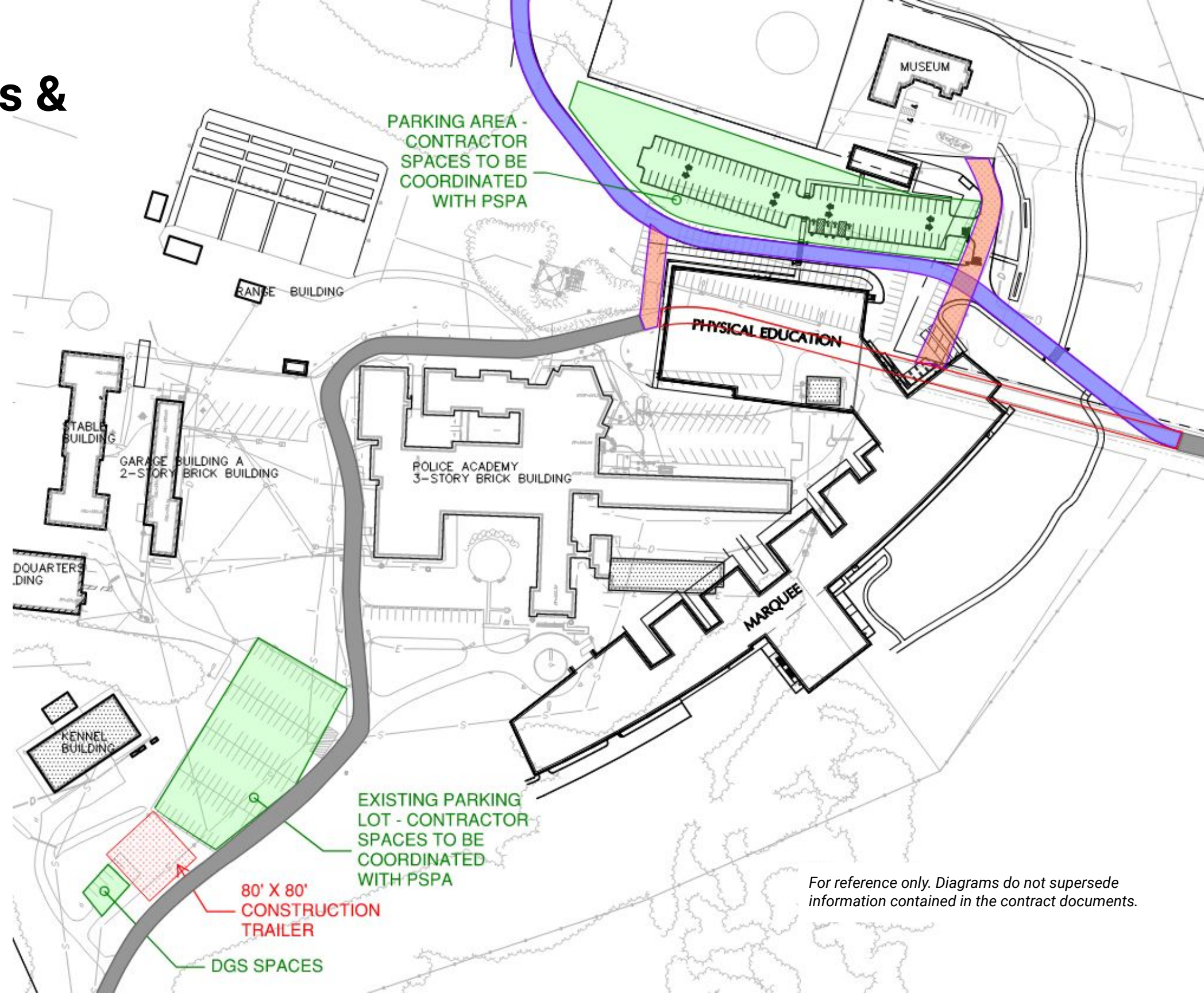

Constructions Logistics & Access

Phased Development Conditions

- North Drive and entrance should and can be utilized for construction logistics, hauling, and deliveries.
 - Please note designated truck route along Swatara
- Additional staging, parking and laydown areas through site depending on phasing & coordination between package 1 and package 2 contractors

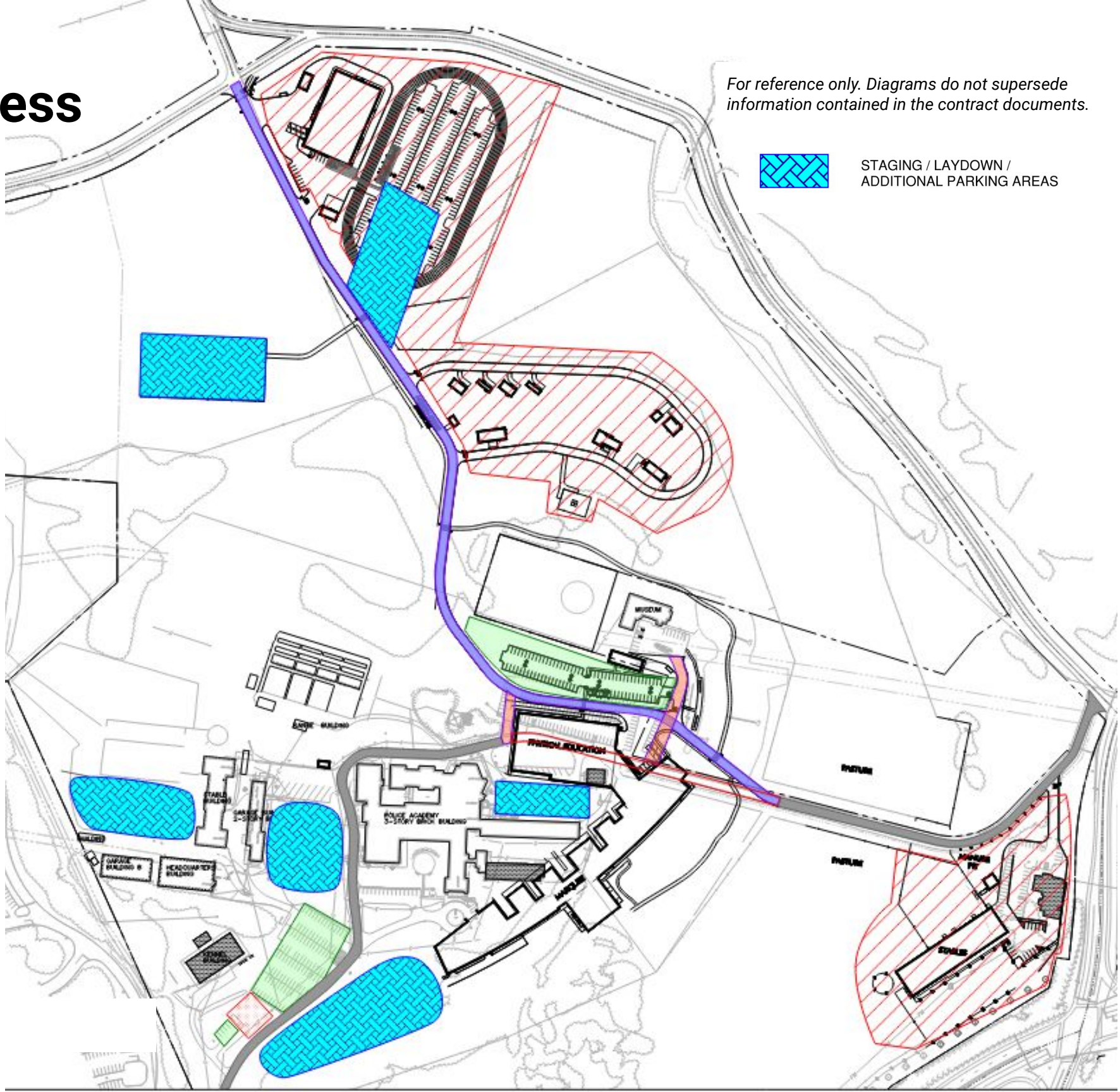

Q & A

Reminders

All proposers should SIGN IN.

Attendance is strongly suggested but not mandatory.

All bidder questions must be submitted through E-Builder under the Questions/Responses tab.

Verbal responses are non-binding. Only written formal responses in the form of an official project Addendum are to be used for bidding purposes.

Deadline to submit questions is July 18, 2023 @ 5pm.

Proposals are due August 1, 2023 @ 2pm.

The Project timeline does not include the opportunity for DGS to extend the bid. All bidders should plan their time accordingly.



Thank You

SOM

.1 General Contractor

- All responsibilities for the lead contractor as established by the Department's General Conditions, Division 1 and technical specifications
- All work pertaining to the 0.1 contractor shown in the contract drawings and specifications
- Salvage, cleaning and storage of 2,500 bricks from the existing academy building.
- Partial demolition of the Administrative wing of the main academy building to the extents indicated on the drawings.
- Total demolition of existing buildings and structures as shown to be demolished on the drawings: Academy "shoot house", Water tower, Stables, Maintenance building, BESO Headquarters and covered parking/ garage, misc structures, BESO Stables, Main Academy Building
- Demolition of existing site utilities
- Site work and major site infrastructure
- Relocation of the existing BESO storage containers
- Constructions of all buildings, outbuildings, and secondary structures
- All subgrade waterproofing
- Installation of foundation sleeves furnished by other prime contractors
- All primary Structural work
- Exterior enclosure
- Miscellaneous metal framing and supports
- Cold formed metal framing and supports
- Stonework
- Interior partitions
- Ceilings
- Interior and exterior doors
- Interior vision panels & storefronts
- Interior and exterior finishes
- Specialties including metal lockers, toilet/bath/shower accessories, toilet/shower partitions, fire extinguishers & cabinets, magnetic glass whiteboards
- Millwork and casework
- Specialty wall and partition construction for interior tactical mazing walls and facades
- Laundry equipment
- Kitchen & cafeteria equipment (excluding hoods)
- Vertical transportation systems
- Stairs, guardrails, handrails
- Hazardous materials abatement (including radon mitigation)
- Foundations/ supports for heavy equipment
- Firing range equipment & baffling
- Temporary construction as required

.2 Mechanical Contractor

- The usual heating, ventilation and air-conditioning work, including controls, piping, ductwork AHU's, fan coil, exhaust fans, heat exchangers and pumps
- Site distribution of, hot water and chilled water (buried underground between Marquee and FTU)
- Light weight equipment supports and housekeeping pads
- Central plant and HVAC equipment controls
- All associated water treatment systems for hydronic systems under the 0.2 contract
- Furnishing of Intake and exhaust louvers to be installed by the .1 General Contractor
- All fuel tanks and fuel lines excluding vehicle refueling tanks and other isolated specialty tanks under a .1 contract
- Cathodic protection for steel tanks
- Well drilling and pipe installation for geothermal systems
- HVAC connections for kitchen equipment, laundry equipment and any equipment provided by others that requires HVAC connections
- Kitchen hood systems including hood, ductwork, exhaust fans and controls
- Electric resistance heating
- In slab heating
- Below slab ductwork
- Hazmat work associated with the HVAC contractor's work
- System start-up
- Commissioning and balancing and training
- BMS and controls system

.3 Plumbing Contractor

- The usual plumbing work for buildings including water, sanitary and rain water conductors for building system, within 5'-0" of the exterior building line
- All gas piping and connections for building systems and from the gas meter to the service point.
- Insulation of all piping and equipment as shown in the drawings and specifications
- Water treatment equipment
- Pool equipment, pumps and associated pumping
- Chlorinated water treatment systems associated with the pool equipment.
- Domestic water and fire water pumps
- Central pump house equipment
- Painting of sprinkler pipe and gas pipe as shown on the contract drawings and specifications
- Compressed air systems
- Vacuum Systems
- Fly spray systems
- Horse wash system
- Air-conditioning drainage systems
- Grease, oil and lint trap systems within buildings and grease/oil traps and piping exterior to buildings.
- Furnishing of roof drains to be installed by the .1 General Contractor
- Rainwater conductors from roof drains
- Fire suppression system
- Equipment supports and housekeeping pads
- Grinder pumps and sewage tank as shown on the drawings
- Hazardous materials work associated with the plumbing contractors work
- Testing, disinfection of water system, adjusting and placing in operation all systems installed

.4 Electric Contractor

- The usual electrical work for buildings including power, lighting, communications, security and fire alarm
- Electrical service points of entry
- Transformer stations, complete, including fences
- Site lighting
- Electrical power generators and transfer switches, including sub-base tanks, mufflers, exhaust piping and outdoor enclosures. Day tank and muffler to be furnished to .2 HVAC Contractor
- Electrical power, starters, overload protection and disconnecting means for all HVAC and Plumbing equipment where not furnished integral to the equipment.
- Telecommunications structured cabling pathways, provide cabling, outlets and terminal unless otherwise directed
- Fire alarm systems including connections for elevators, air handling equipment and door hardware
- Security including access control, video surveillance systems and intrusion/ various alarms
- Public address systems
- Central clock system
- Electrical connections for kitchen equipment, laundry equipment and other equipment furnished by others that requires electrical connections
- Equipment supports and housekeeping pads
- Hazardous materials work associated with the electrical equipment removal or installation
- Lighting protection
- Installation of all site network pathways, including conduits and service vaults
- Installation, testing and completion of all Information Technology Audio-Visual and Physical Security equipment cabling, devices and systems

Base Bids

BASE BID 1: Marquee, Gym, Firearms Buildings

- All associated site work (entry plaza, quad)
- Construction & realignment of Police Academy Drive East
- Geothermal well field
- Site utilities & stormwater within the base bid disturbance area and necessary to service the 3 buildings
- Abatement & demolition of the existing academy building & shoot house
- Removal of existing utilities that are replaced or within the disturbance area

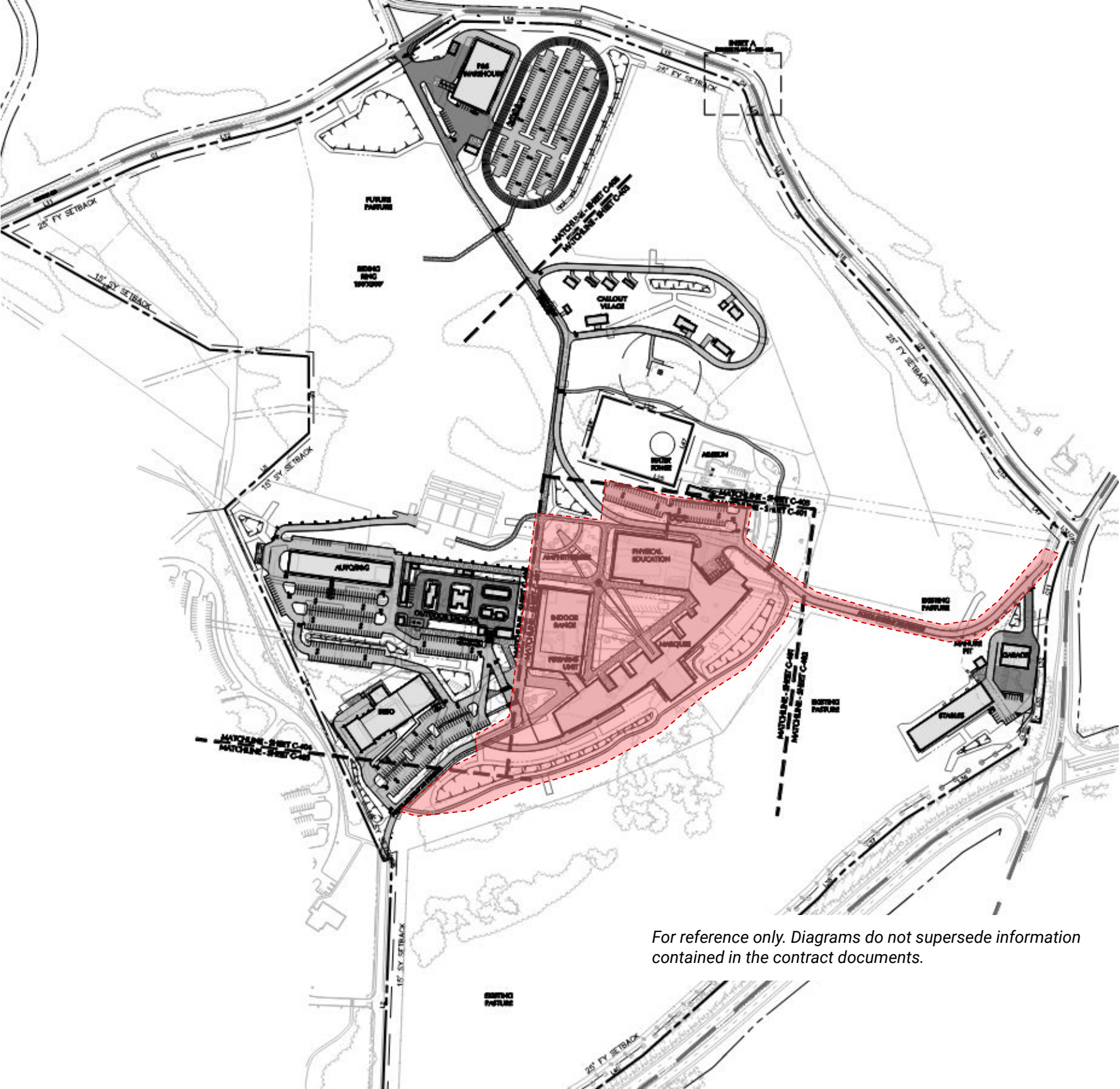

For reference only. Diagrams do not supersede information contained in the contract documents.

Base Bids

BASE BID 2: BESO, Auto/ B&G, P&S Warehouse, Stables, Museum Garage, OTV

- All associated site work
- Sacrifice lot & pasture fencing for stable
- Main parking lot, BESO parking lot, Stables Parking Lot, P&S Warehouse parking lot
- Regrading of Police Academy Drive West
- 400m track and cadet parking
- All OTV sitework and roads
- Extensions of site utilities
- Above ground gasoline & diesel tanks
- Abatement & demo of existing stables, automotive building, facilities building, kennels



For reference only. Diagrams do not supersede information contained in the contract documents.

Base Bids

BASE BID 3: Stables Garage, Outdoor Riding Ring

- All associated site work and stormwater management
- Extensions of site utilities

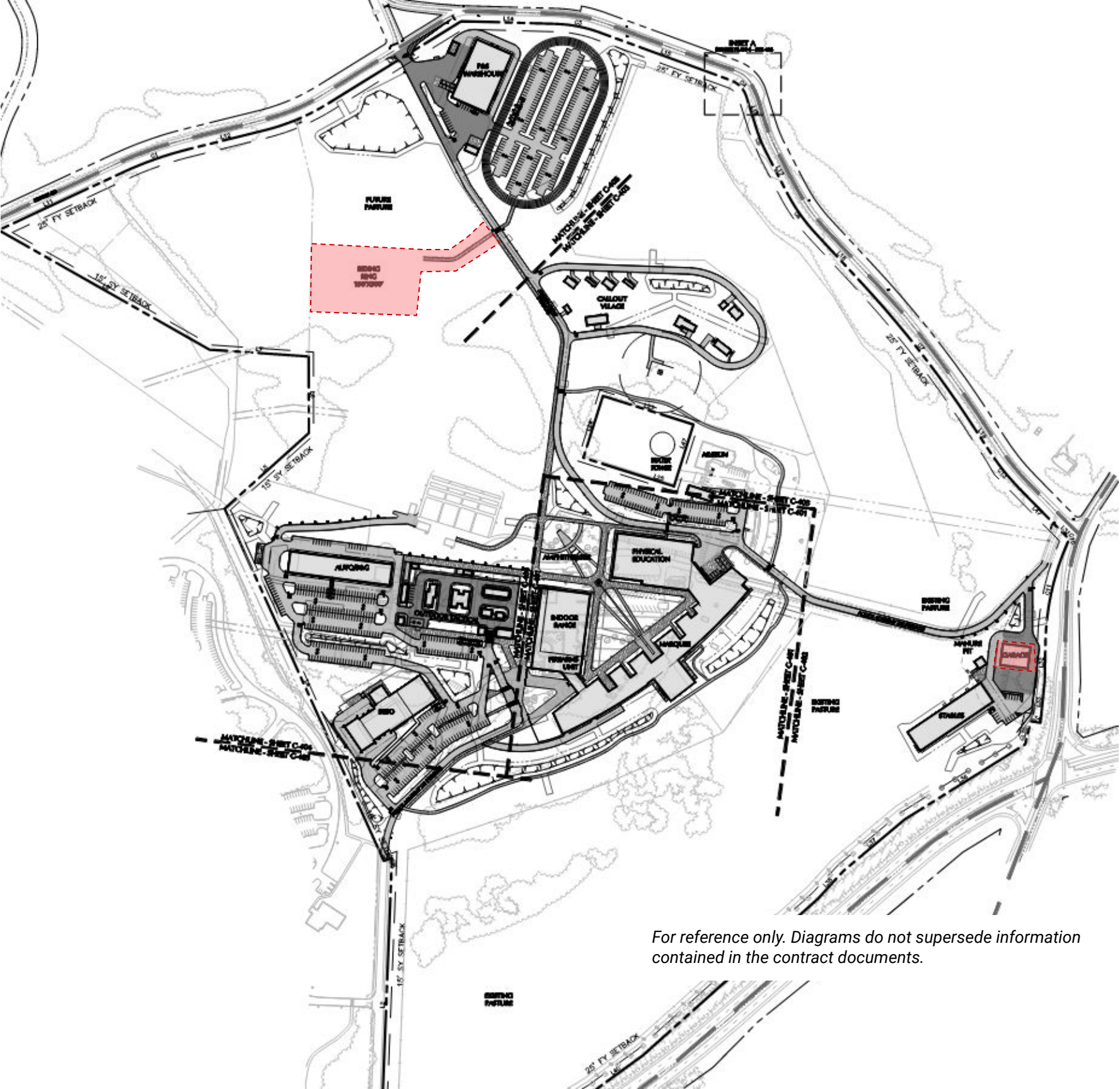

For reference only. Diagrams do not supersede information contained in the contract documents.

Base Bids

BASE BID 4: Callout Village

- All associated site work and stormwater management
- Extensions of site utilities



Base Bids

BASE BID 5: Outdoor Firearms Range

- Construction of new range house
- Erection of baffling system
- All associated site work and stormwater management
- Extensions of site utilities
- Abatement & demolition of existing range house

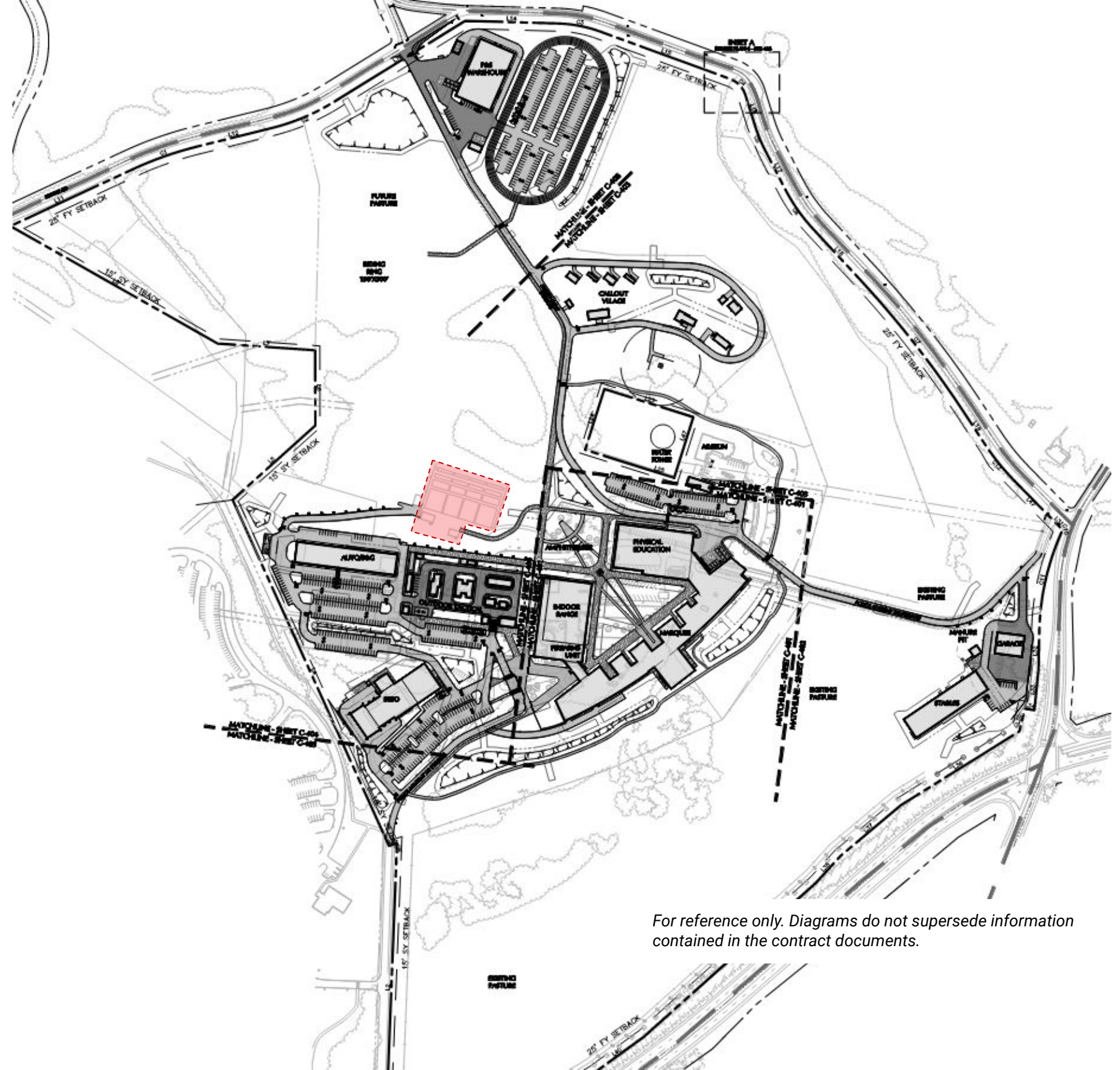

For reference only. Diagrams do not supersede information contained in the contract documents.

Drawing Review - Training Villages

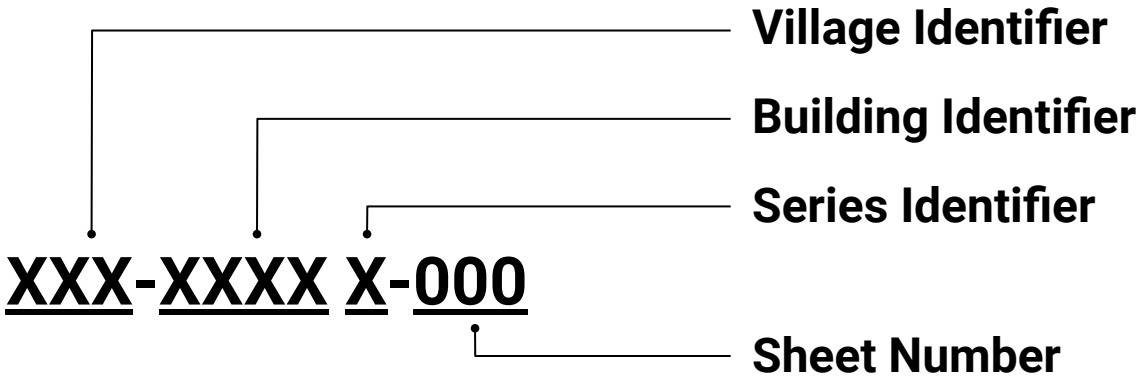

Village Identifier

- OTV Outdoor Training Village
- COV Callout Training Village

**All buildings in blue are non-training support facilities.

Building Identifier -OTV

- C6 Gas Station
- C8 Strip Mall
- C457 5 Story Commercial
- DC Dirty Classroom
- EC Entrance Canopy
- I2I3 Institutional Building
- P2 Outdoor Pavilion
- PH Pump House
- R3 1 Story House
- R4 2 Story House
- R5 4 Family Row House
- S Storage

Building Identifier - COV

- B1 Barn
- C1 Church
- P1 Pavilion
- R7A Tri Level House
- R7B 1 Story House
- R8A Residential Trailer A
- R8B Residential Trailer B
- R8C Residential Trailer C
- R8D Residential Trailer D

SECTION 230000
HEATING, VENTILATING AND AIR CONDITIONING (HVAC) BASIC REQUIREMENTS

PART 1 - GENERAL

1.1 SECTION INCLUDES

- A. Stipulations:
1. The specifications sections "General Conditions to the Construction Contract", "Special Conditions" and "Division 01 - General Requirements" form a part of this Section by this reference thereto, and shall have the same force and effect as if printed herewith in full.
- B. Work included in 23 00 00, HVAC Basic Requirements applies to Division 23, HVAC work to provide materials, labor, tools, permits, incidentals, and other services to provide and make ready for Department's use of heating, ventilating and air conditioning systems for proposed project.
- C. Contract Documents include, but are not limited to, Specifications including Division 00, Procurement and Contracting Requirements and Division 01, General Requirements, Drawings, Addenda. Confirm requirements before commencement of work.
- D. Definitions:
1. Provide: To furnish and install, complete and ready for intended use.
 2. Furnish: Supply and deliver to project site, ready for unpacking, assembly and installation.
 3. Install: Includes unloading, unpacking, assembling, erecting, installation, applying, finishing, protecting, cleaning and similar operations at project site as required to complete items of work provided.
 4. Approved or Approved Equivalent: To possess the same performance qualities and characteristics and fulfill the utilitarian function without any decrease in quality, durability or longevity. For equipment/products defined by the Contractor as "equivalent", substitution requests must be submitted to Professional for consideration, in accordance with Division 01, General Requirements, and approved by the Department prior to submitting bids for substituted items.
 5. Authority Having Jurisdiction (AHJ): Indicates reviewing authorities, including local fire marshal, Department's insurance underwriter, Department's Authorized Representative, and other reviewing entity whose approval is required to obtain systems acceptance.

1.2 RELATED SECTIONS

- A. Contents of Section applies to Division 23, HVAC Contract Documents.

- B. Related Work:
1. Additional conditions apply to this Division including, but not limited to:
 - a. Specifications including Division 00, Procurement and Contracting Requirements and Division 01, General Requirements.
 - b. Drawings
 - c. Addenda
 - d. Department/Contractor Agreement
 - e. Codes, Standards, Public Ordinances and Permits

1.3 REFERENCES AND STANDARDS

- A. References and Standards per Division 01, General Requirements, individual Division 23, HVAC Sections and those listed in this Section.
- B. Codes to include latest adopted editions, including current amendments, supplements and local jurisdiction requirements in effect as of the date of the Contract Documents, of/from:
1. Commonwealth of Pennsylvania:
 - a. 2015 International Building Code
 - b. 2015 International Fuel Gas Code
 - c. 2015 International Energy Conservation Code
 - d. 2015 International Existing Building Code
 - e. 2015 International Plumbing Code
 - f. 2015 International Mechanical Code
 - g. 2015 International Residential Code
- C. Reference standards and guidelines include but are not limited to the latest adopted editions from:
1. ABA - Architectural Barriers Act
 2. ABMA - American Bearing Manufacturers Association
 3. ADA - Americans with Disabilities Act
 4. AHRI - Air-Conditioning Heating & Refrigeration Institute
 5. AMCA - Air Movement and Control Association

6. ANSI - American National Standards Institute
7. ASCE - American Society of Civil professionals
8. ASHRAE - American Society of Heating, Refrigeration and Air-Conditioning professionals
9. ASHRAE Guideline 0, The Commissioning Process
10. ASME - American Society of Mechanical professionals
11. ASPE - American Society of Plumbing professionals
12. ASSE - American Society of Sanitary professionals
13. ASTM - ASTM International
14. AWWA - American Water Works Association
15. CFR - Code of Federal Regulations
16. CGA - Compressed Gas Association
17. CISPI - Cast Iron Soil Pipe Institute
18. EPA - Environmental Protection Agency
19. ETL - Electrical Testing Laboratories
20. FM - FM Global
21. GAMA - Gas Appliance Manufacturers Association
22. HI - Hydraulic Institute Standards
23. ICC - International Code Council
24. IFGC - International Fuel Gas Code
25. ISO - International Organization for Standardization
26. MSS - Manufacturers Standardization Society
27. NEC - National Electric Code
28. NEMA - National Electrical Manufactures Association
29. NFPA - National Fire Protection Association
30. NFGC - National Fuel Gas Code

31. NRCA - National Roofing Contractors Association
 32. NSF - National Sanitation Foundation
 33. OSHA - Occupational Safety and Health Administration
 34. SMACNA - Sheet Metal and Air Conditioning Contractors' National Association, Inc.
 35. TEMA - Tubular Exchanger Manufacturers Association
 36. TIMA - Thermal Insulation Manufacturers Association
 37. UL - Underwriters Laboratories, Inc.
- D. See Division 23, HVAC individual Sections for additional references.

1.4 SUBMITTALS

- A. See Division 01, General Requirements for Submittal Procedures as well as specific individual Division 23, HVAC Sections.
- B. Provide drawings in format and software release equal to the design documents. Drawings to be the same sheet size and scale as the Contract Documents.
- C. In addition:
 1. "No Exception Taken" constitutes that review is for general conformance with the design concept expressed in the Contract Documents for the limited purpose of checking for conformance with information given. Any action is subject to the requirements of the Contract Documents. Contractor is responsible for the dimensions and quantity and will confirm and correlate at the job site, fabrication processes and techniques of construction, coordination of the work with that of all other trades, and the satisfactory performance of the work.
 2. Provide product submittals and shop drawings in electronic format only. Electronic format must be submitted via zip file via e-mail and be native/searchable PDF format. Scanned copies are not acceptable. For electronic format, provide one file per division containing one bookmarked PDF file with each bookmark corresponding to each Specification Section. Arrange bookmarks in ascending order of Specification Section number. Individual submittals sent piecemeal in a per Specification Section method will be returned without review or comment. All transmissions/submissions to be submitted to Professional. At Contractor's option, four separate submittals may be provided, consisting of long lead items, underground/site work, building work, and building automation system. Deviations will be returned without review.
 3. Product Data: Provide Manufacturer's descriptive literature for products specified in Division 23, HVAC Sections.

4. Identify/mark each submittal in detail. Note what differences, if any, exist between the submitted item and the specified item. Failure to identify the differences will be considered cause for disapproval. If differences are not identified and/or not discovered during the submittal review process, Contractor remains responsible for providing equipment and materials that meet the Specifications and Drawings.
 - a. Label submittal to match numbering/references as shown in Contract Documents. Highlight and label applicable information to individual equipment or cross out/remove extraneous data not applicable to submitted model. Clearly note options and accessories to be provided, including field installed items. Highlight connections by/to other trades.
 - b. Include technical data, installation instructions and dimensioned drawings for products, fixtures, equipment and devices installed, furnished or provided. Reference individual Division 23, HVAC Specification Sections for specific items required in product data submittal outside of these requirements.
 - c. Provide pump curves, operation characteristics, capacities, ambient noise criteria, etc. for equipment.
 - d. For vibration isolation of equipment, list make and model selected with operating load and deflection.
 - e. See Division 23, HVAC individual Sections for additional submittal requirements outside of these requirements.
5. Maximum of two reviews of submittal package. Arrange for additional reviews and/or early review of long-lead items; Bear costs of these additional reviews at Professional's hourly rates. Incomplete submittal packages/submittals will be returned to contractor without review.
6. Resubmission Requirements: Make corrections or changes in submittals as required, and in consideration of professional's comments. Identify Professional's comments and provide an individual response to each of the Professional's comments. Cloud changes in the submittals and further identify changes which are in response to Professional's comments.
7. Structural/Seismic: Provide weights, dimensions, mounting requirements and like information required for mounting and support. Indicate manufacturer's installation and support requirements to meet Section 23 05 48, Vibration and Seismic Controls for HVAC Equipment. Equipment Importance Factor as specified in Division 01 and in Structural documents.
8. Trade Coordination: Include physical characteristics, electrical characteristics, device layout plans, wiring diagrams, and connections as required by Division 23, HVAC Coordination Documents. For equipment with electrical connections, furnish

copy of approved submittal for inclusion in Division 26, Electrical submittals.

9. Make provisions for openings in building for admittance of equipment prior to start of construction or ordering of equipment.
10. Substitutions and Variation from Basis of Design:
 - a. The Basis of Design designated product establishes the qualities and characteristics for the evaluation of any comparable products by other listed acceptable manufacturers if included in this Specification or included in an approved Substitution Request as judged by the Design Professional.
 - b. If substitutions and/or equivalent equipment/products are being proposed, it is the responsibility of parties concerned, involved in, and furnishing the substitute and/or equivalent equipment to verify and compare the characteristics and requirements of that furnished to that specified and/or shown. If greater capacity and/or more materials and/or more labor is required for the rough-in, circuitry or connections than for the item specified and provided for, then provide compensation for additional charges required for the proper rough-in, circuitry and connections for the equipment being furnished. No additional charges above the Base Bid, including resulting charges for work performed under other Divisions, will be allowed for such revisions. Coordinate with the requirements of "Submittals". For any product marked "or approved equivalent", a substitution request must be submitted to Department for approval prior to purchase, delivery or installation.
11. Shop Drawings: Provide coordinated shop drawings which include physical characteristics of all systems, equipment, ductwork and piping layout plans, and control wiring diagrams. Reference individual Division 23, HVAC Specification Sections for additional requirements for shop drawings outside of these requirements.
 - a. Provide Shop Drawings indicating access panel locations for items that require Code or maintenance access, size and elevation for approval prior to installation.
12. Samples: Provide samples when requested by individual Sections.
13. Resubmission Requirements:
 - a. Make any corrections or change in submittals when required. Provide submittals as specified. The Professional will not be required to edit and/or interpret the Contractor's submittals. Indicate changes for the resubmittal in a cover letter with reference to page(s) changed and reference response to comment. Cloud changes in the submittals.
 - 1) Resubmit for review until review indicates no exception taken or make "corrections as noted".

- 2) When submitting drawings for Professionals re-review, clearly indicate changes on drawings and "cloud" any revisions. Submit a list describing each change.

14. Operation and Maintenance Manuals, Owner's Instructions:

- a. Submit, at one time, electronic files (native/searchable PDF format) of manufacturer's operation and maintenance instruction manuals and parts lists for equipment or items requiring servicing. Include valve charts. Submit data when work is substantially complete and in same order format as submittals. Include name and location of source parts and service for each piece of equipment.
 - 1) Include copy of approved submittal data along with submittal review letters received from Professional. Data to clearly indicate installed equipment model numbers. Delete or cross out data pertaining to other equipment not specific to this project.
 - 2) Include copy of manufacturer's standard Operations and Maintenance for equipment. At front of each tab, provide routine maintenance documentation for scheduled equipment. Include manufacturer's recommended maintenance schedule and highlight maintenance required to maintain warranty. Furnish list of routine maintenance parts, including part numbers, sizes, quantities, relevant to each piece of equipment: belts, motors, lubricants, and filters.
 - 3) Include Warranty per Division 00, Procurement and Contracting Requirements and Division 01, General Requirements, Section 23 00 00, HVAC Basic Requirements and individual Sections.
 - 4) Include product certificates of warranties and guarantees.
 - 5) Include copy of complete parts list for equipment. Include available exploded views of assemblies and sub assemblies.
 - 6) Include copy of startup and test reports specific to each piece of equipment.
 - 7) Include copy of final air and water systems balancing log along with pump, fan and distribution system operating data.
 - 8) Include commissioning reports.
 - 9) Include copy of valve charts/schedules.
 - 10) Professional will return incomplete documentation without review. Professional will provide one set of review comments in Submittal

Review format. Contractor must arrange for additional reviews; Contractor to bear costs for additional reviews at Professional's hourly rates.

- b. Thoroughly instruct Department in proper operation of equipment and systems. Where noted in individual Sections, training will include classroom instruction with applicable training aids and systems demonstrations. Field instruction per Section 23 00 00, HVAC Basic Requirements Article titled "Demonstration".
- c. Copies of certificates of code authority inspections, acceptance, code required acceptance tests, letter of conformance and other special guarantees, certificates of warranties, specified elsewhere or indicated on Drawings.

15. Record Drawings:

- a. Maintain at site at least one set of drawings for recording "As-constructed" conditions. Indicate on drawings changes to original documents by referencing revision document, and include buried elements, location of cleanouts, and location of concealed mechanical items. Include items changed by field orders, supplemental instructions, and constructed conditions.
- b. Record Drawings are to include equipment and fixture/connection schedules, control dampers, fire smoke dampers, fire dampers, valves, bottom of pipe, duct and equipment elevations and dimensioned locations for all distribution systems (hydronic and air). Invert elevations and dimensioned locations for underground systems below grade to 5-feet outside building that accurately reflect "as constructed or installed" for project.
- c. At completion of project, input changes to original project CAD Drawings or Revit Model and make one set of black-line drawings created from CAD Files or Revit Model in version/release equal to contract drawings. Submit CAD or Revit disk and drawings upon substantial completion.
- d. See Division 23, HVAC individual Sections for additional items to include in record drawings.

1.5 QUALITY ASSURANCE

- A. Regulatory Requirements: Work and materials installed to conform with all local, Commonwealth and Federal codes, and other applicable laws and regulations. Where code requirements are at variance with Contract Documents, meet code requirements as a minimum requirement and include costs necessary to meet these in Contract. Machinery and equipment are to comply with OSHA requirements, as currently revised and interpreted

for equipment manufacturer requirements. Install equipment provided per manufacturer recommendations.

- B. Whenever this Specification calls for material, workmanship, arrangement or construction of higher quality and/or capacity than that required by governing codes, higher quality and/or capacity take precedence.
- C. Drawings are intended to be diagrammatic and reflect the Basis of Design manufacturer's equipment. They are not intended to show every item in its exact dimensions, or details of equipment or proposed systems layout. Verify actual dimensions of systems (i.e., piping) and equipment proposed to assure that systems and equipment will fit in available space. Contractor is responsible for design and construction costs incurred for equipment other than Basis of Design, including, but not limited to, architectural, structural, electrical, HVAC, fire sprinkler, and plumbing systems.
- D. Manufacturer's Instructions: Follow manufacturer's written instructions. If in conflict with Contract Documents, obtain clarification. Notify Professional, in writing, before starting work.
- E. Items shown on Drawings are not necessarily included in Specifications or vice versa. Confirm requirements in all Contract Documents.
- F. Provide products that are UL listed.
- G. Piping and duct insulation products to contain less than 0.1 percent by weight PBDE in all insulating materials.
- H. ASME Compliance: ASME listed water heaters and boilers with an input of 200,000 BTUH and higher, hot water storage tanks which exceed 120 gallons, and hot water expansion tanks which are connected to ASME rated equipment or required by code or local jurisdiction.
- I. Provide safety controls required by National Boiler Code (ASME CSD 1) for boilers and water heaters with an input of 400,000 BTUH and higher.

1.6 WARRANTY

- A. Provide written warranty covering the work for a period of one year from date of Substantial Completion in accordance with Division 00, Contracting and Procurement Requirements, Division 01, General Requirements, Section 23 00 00, HVAC Basic Requirements and individual Division 23, HVAC Sections.
- B. Sections under this Division can require additional and/or extended warranties that apply beyond basic warranty under Division 01, General Requirements and the General Conditions. Confirm requirements in all Contract Documents.

1.7 COORDINATION DOCUMENTS

- A. Prior to construction, prepare and submit coordinated layout drawings (composite drawings), to coordinate installation and location of ductwork, grilles, diffusers, piping, fire sprinklers, plumbing, lights, and electrical services. Composite Drawings show services on single sheet. Key Drawings to structural column identification system. Prior to completion of Drawings, coordinate proposed installation with architectural and structural requirements, and other trades (including plumbing, HVAC, fire protection, electrical, ceiling suspension, and ceiling tile systems, etc.), and provide maintenance access requirements. Coordinate with submitted architectural systems (i.e. roofing, ceiling, finishes) and structural systems as submitted, including footings and foundation. Identify zone of influence from footings and ensure systems are not routed within the zone of influence. Unless otherwise required by Division 00, Procurement and Contracting Requirements and/or Division 01, General Requirements, Division 23, HVAC to combine information furnished by other trades onto master coordination documents.
- B. Prepare Drawings as follows:
1. Coordination models/drawings may be created using Revit 3D modeled elements or a 3D CAD software. The modeled elements to be graphically represented within the model as a specific system, object or assembly in terms of size, shape, location, quantity, and orientation with detailing, fabrication, assembly, and installation information. Non-graphic information may also be attached to the model elements. Model elements must have the ability to be spatially coordinated with other modeled elements using either Revit, Autodesk Navisworks or Autodesk A360.
 2. Drawings in CAD Format or Revit Model. CAD format or Revit Model release equal to design documents. Drawings to be same sheet size and scale as Contract Drawings and indicate location, size and elevation above finished floor of equipment and distribution systems.
 3. Review and revise, as necessary, section cuts in Contract Drawings after verification of field conditions.
 4. Indicate hydronic and air distribution system piping including fittings, hangers, access panels, valves, and bottom of pipe and duct elevations above finished floor.
 5. Indicate inverts and provision for piping that must be graded to have right-of-way over more flexible items. Drawings also to indicate proposed ceiling grid and lighting layout as shown on electrical drawings and architectural reflected ceiling drawings and HVAC equipment, ductwork and piping.
 6. Incorporate Addenda items and change orders.
 7. Distribute drawings to trades and provide additional coordination as requested by other trades.
- C. Advise Professional in event conflict occurs in location or connection of equipment. Bear costs resulting from failure to properly coordinate installation or failure to advise Professional

of conflict.

- D. Submit final Coordination Drawings with changes as Record Drawings at completion of project.

PART 2 - PRODUCTS

2.1 MANUFACTURERS

- A. Articles, fixtures, and equipment of a kind to be standard product of one manufacturer, including but not limited to pumps, fans, valves, control devices, air handlers, vibration isolation devices, etc.

2.2 STANDARDS OF MATERIALS AND WORKMANSHIP

- A. Base contract upon furnishing materials as specified. Materials, equipment, and fixtures used for construction are to be new, latest products as listed in manufacturer's printed catalog data and are to be UL or ETL approved or have adequate approval or be acceptable by Commonwealth, County, and City authorities.
- B. Names and manufacturer's names denote character and quality of equipment desired and are not to be construed as limiting competition.
- C. Hazardous Materials:
 - 1. Comply with local, Commonwealth of Pennsylvania, and Federal regulations relating to hazardous materials.
 - 2. Comply with Division 00, Procurement and Contracting Requirements and Division 01, General Requirements for this project relating to hazardous materials.
 - 3. Do not use any materials containing a hazardous substance. If hazardous materials are encountered, do not disturb; immediately notify the Department and Professional. Hazardous materials will be removed by Department under separate contract.

PART 3 - EXECUTION

3.1 ACCESSIBILITY AND INSTALLATION

- A. Confirm Accessibility and Installation requirements in Division 00, Procurement and Contracting Requirements and Division 01, General Requirements, Section 23 00 00, HVAC Basic Requirements and individual Division 23, HVAC Sections.
- B. Install equipment having components requiring access (i.e., drain pans, drains, control operators, valves, motors and vibration isolation devices) so that they may be serviced, reset, replaced or recalibrated by service people with normal service tools and equipment. Do not install equipment in obvious passageways, doorways, scuttles or crawlspaces which would impede or block intended usage.

- C. Install equipment and products complete as directed by manufacturer's installation instructions including all appurtenances recommended in manufacturer's installation instructions, at no additional charge to the Department. Obtain installation instructions from manufacturer prior to rough-in of equipment and examine instructions thoroughly. When requirements of installation instructions conflict with Contract Documents, request clarification from Professional prior to proceeding with installation. This includes proper installation methods, sequencing and coordination with other trades and disciplines.
- D. Earthwork:
1. Confirm Earthwork requirements in Contract Documents. In absence of specific requirements, comply with individual Division 23, HVAC Sections and the following:
 - a. Perform excavation, dewatering, shoring, bedding, and backfill required for installation of work in this Division in accordance with related earthwork Sections. Contact utilities and locate existing utilities prior to excavation. Repair any work damaged during excavation or backfilling.
 - b. Excavation: Do not excavate under footings, foundation bases, or retaining walls.
 - c. Provide protection of underground systems. Review the project Geotechnical Report for references to corrosive or deleterious soils which will reduce the performance or service life of underground systems materials.
- E. Firestopping:
1. Confirm Firestopping requirements in Division 07, Thermal and Moisture Protection. In absence of specific requirements, comply with individual Division 23, HVAC Sections and the following:
 - a. Coordinate location and protection level of fire and/or smoke rated walls, ceilings, and floors. When these assemblies are penetrated, seal around piping, ductwork and equipment with approved firestopping material. Install firestopping material complete as directed by manufacturer's installation instructions. Meet requirements of ASTM E814, Standard Test Method for Fire Tests of Through-Penetration Fire Stops.
- F. Pipe Installation:
1. Provide installation of piping systems coordinated to account for expansion and contraction of piping materials and building, as well as anticipated settlement or shrinkage of building. Install work to prevent damage to piping, equipment, and building and its contents. Provide piping offsets, loops, seismic flexible joints, expansion joints, sleeves, anchors or other means to control pipe movement and minimize forces on piping. Verify anticipated settlement and/or shrinkage of building with Project Structural professional. Verify construction phasing, type of building

construction products and rating for coordinating installation of piping systems. See Section 23 05 16 for additional information.

2. Include provisions for servicing and removal of equipment without dismantling piping.

G. Plenums:

1. Plenums: Materials within plenums shall be noncombustible or shall have a flame spread index of not more than 25 and a smoke-developed index of not more than 50 when tested in accordance with ASTM E 84 or UL 723. Immediately notify Professional of any discrepancy.

3.2 REVIEW AND OBSERVATION

A. Confirm Review and Observation requirements in Division 00, Procurement and Contracting Requirements, Division 01, General Requirements, Section 23 00 00, HVAC Basic Requirements and individual Division 23, HVAC Sections.

B. Notify Professional, in writing, at following stages of construction so that they may, at their option, visit site for review and construction observation:

1. Underground system installation prior to backfilling.
2. Prior to covering walls.
3. Prior to ceiling cover/installation.
4. After major equipment is installed.
5. When main systems, or portions of, are being tested and ready for inspection by AHJ.

C. Final Punch:

1. Prior to requesting a final punch visit from the Professional, request from Professional the Mechanical Precloseout Checklist, complete the checklist confirming completion of systems' installation, and return to Professional. Request a final punch visit from the Professional, upon Professional's acceptance that the mechanical systems are ready for final punch.
2. Costs incurred by additional trips required due to incomplete systems will be the responsibility of the Contractor.

3.3 CUTTING AND PATCHING

A. Confirm Cutting and Patching requirements in Division 00, Procurement and Contracting Requirements and Division 01, General Requirements. In absence of specific requirements, comply with individual Division 23, HVAC Sections and the following:

1. Proposed floor cutting/core drilling/sleeve locations to be approved by Project Structural professional. Submit proposed locations to Project Structural professional. Where slabs are of post tension construction, perform x-ray scan of proposed penetration locations and submit scan results including proposed penetration locations to Project Structural professional for approval. Where slabs are of waffle type construction, show column cap extent and cell locations relative to proposed penetration(s).
2. Cutting, patching and repairing for work specified in this Division including plastering, masonry work, concrete work, carpentry work, and painting included under this Section will be performed by skilled craftsmen of each respective trade in conformance with appropriate Division of Work.
3. Additional openings required in building construction to be made by drilling or cutting. Use of jack hammer is specifically prohibited. Patch openings in and through concrete and masonry with grout.
4. Restore new or existing work that is cut and/or damaged to original condition. Patch and repair specifically where existing items have been removed. This includes repairing and painting walls, ceilings, etc. where existing conduit and devices are removed as part of this project. Where alterations disturb lawns, paving, and walks, surfaces to be repaired, refinished and left in condition matching existing prior to commencement of work.
5. Additional work required by lack of proper coordination will be provided at no additional cost to the Department.

3.4 EQUIPMENT SELECTION AND SERVICEABILITY

- A. Replace or reposition equipment which is too large or located incorrectly to permit servicing, at no additional cost to Department.
- B. Maintain design intent where equipment other than as shown as Basis of Design in Contract Documents is provided. Where equipment requires ductwork or piping arrangement, controls/control diagrams, or sequencing different from that indicated in Contract Documents, provide at no additional cost to Department.

3.5 DELIVERY, STORAGE AND HANDLING

- A. Confirm requirements in Division 00, Procurement and Contracting Requirements and Division 01, General Requirements. In absence of specific requirements, comply with individual Division 23, HVAC Sections and the following:
 1. Handle materials delivered to project site with care to avoid damage. Store materials on site inside building or protected from weather, dirt and construction dust. Insulation and lining that becomes wet from improper storage and handling to be replaced before installation. Products and/or materials that become damaged due to water, dirt, and/or dust as a result of improper storage to be replaced before

installation.

2. Protect equipment and pipe to avoid damage. Close pipe openings with caps or plugs. Keep motors and bearings in watertight and dustproof covers during entire course of installation.
3. Protect bright finished shafts, bearing housings and similar items until in service.

3.6 DEMONSTRATION

- A. Confirm Demonstration requirements in Division 00, Procurement and Contracting Requirements and Division 01, General Requirements, Section 23 00 00, HVAC Basic Requirements and individual Division 23, HVAC Sections.
- B. Upon completion of work and adjustment of equipment and test systems, demonstrate to the Department and Professional that equipment furnished and installed or connected under provisions of these Specifications functions in manner required. Provide field instruction to Department's Maintenance Staff as specified in Division 01, General Requirements, Section 23 00 00, HVAC Basic Requirements and individual Division 23, HVAC Sections.
- C. Manufacturer's Field Services: Furnish services of a qualified person at time approved by Department, to instruct maintenance personnel, correct defects or deficiencies, and demonstrate to satisfaction of Department that entire system is operating in satisfactory manner and complies with requirements of other trades that may be required to complete work. Complete instruction and demonstration prior to final job site observations.
- D. Training and Demonstration per Section 01 91 13, General Commissioning Requirements and Section 23 08 00, Commissioning of HVAC.

3.7 CLEANING

- A. Confirm Cleaning requirements in Division 00, Procurement and Contracting Requirements, Division 01, General Requirements, Section 23 00 00, HVAC Basic Requirements and individual Division 23, HVAC Sections.
- B. Upon completion of installation, thoroughly clean exposed portions of equipment, removing temporary labels and traces of foreign substances. Throughout work, remove construction debris and surplus materials accumulated during work.

3.8 INSTALLATION

- A. Confirm Installation requirements in Division 00, Procurement and Contracting Requirements, Division 01, General Requirements, Section 23 00 00, HVAC Basic Requirements and individual Division 23, HVAC Sections.
- B. Install equipment and fixtures in accordance with manufacturer's installation instructions, plumb and level and firmly anchored to vibration isolators. Maintain manufacturer's recommended clearances.

- C. Start up equipment, in accordance with manufacturer's start-up instructions, and in presence of manufacturer's representative. Test controls and demonstrate compliance with requirements. Replace damaged or malfunctioning controls and equipment.
 - 1. Do not place equipment in sustained operation prior to initial balancing of HVAC systems.
- D. Provide miscellaneous supports/metals required for installation of equipment, piping and ductwork.

3.9 PAINTING

- A. Confirm Painting requirements in Division 01, General Requirements and Division 09, Finishes. In absence of specific requirements, comply with individual Division 23, HVAC Sections and the following:
 - 1. Ferrous Metal: After completion of work, thoroughly clean and paint exposed supports constructed of ferrous metal surfaces in mechanical rooms, i.e., hangers, hanger rods, equipment stands, with one coat of black asphalt varnish for exterior or black enamel for interior, suitable for hot surfaces.
 - 2. After acceptance by Authority Having Jurisdiction (AHJ), In a mechanical room, on roof or other exposed areas, machinery and equipment not painted with enamel to receive two coats of primer and one coat of rustproof enamel, colors as selected by Professional.
 - 3. See individual equipment Specifications for other painting.
 - 4. Structural Steel: Repair damage to structural steel finishes or finishes of other materials damaged by cutting, welding or patching to match original.
 - 5. Piping and Ductwork: Clean, primer coat and paint exposed piping and ductwork on roof or at other exterior locations with two coats paint suitable for metallic surfaces and exterior exposures. Color selected by Professional.
 - 6. Covers: Covers such as manholes, cleanouts and the like will be furnished with finishes which resist corrosion and rust.

3.10 ACCEPTANCE

- A. Confirm requirements in Division 00, Procurement and Contracting Requirements and Division 01, General Requirements. In absence of specific requirements, comply with individual Division 23, HVAC Sections and the following:
 - 1. System cannot be considered for acceptance until work is completed and demonstrated to Professional that installation is in strict compliance with Specifications, Drawings and manufacturer's installation instructions, particularly in reference to following:

- a. Testing and Balancing Reports
- b. Cleaning
- c. Operation and Maintenance Manuals
- d. Training of Operating Personnel
- e. Record Drawings
- f. Warranty and Guaranty Certificates
- g. Start-up/Test Document
- h. Commissioning Reports

3.11 FIELD QUALITY CONTROL

- A. Confirm Field Quality Control requirements in Division 01, General Requirements, Section 23 00 00, HVAC Basic Requirements and individual Division 23, HVAC Sections.
- B. Tests:
 - 1. Conduct tests of equipment and systems to demonstrate compliance with requirements specified. Reference individual Specification Sections for required tests. Document tests and include in Operation and Maintenance Manuals.
 - 2. During site evaluations by Professional, provide appropriate personnel with tools to remove and replace trims, covers, and devices so that proper evaluation of installation can be performed.

3.12 LETTER OF CONFORMANCE

- A. Provide Letter of Conformance, copies of manufacturers' warranties and extended warranties with a statement that HVAC items were installed in accordance with manufacturer's recommendations, UL listings and FM Global approvals. Include Letter of Conformance, copies of manufacturers' warranties and extended warranties in Operation and Maintenance Manuals.

3.13 ELECTRICAL INTERLOCKS

- A. Where equipment motors are to be electrically interlocked with other equipment for simultaneous operation, utilize equipment wiring diagrams to coordinate with electrical systems so that proper wiring of equipment involved is affected.

END OF SECTION 230000

**SECTION 230700
HVAC INSULATION**

PART 1 - GENERAL

1.1 SUMMARY

A. Stipulations:

1. The specifications sections "General Conditions to the Construction Contract", "Special Conditions" and "Division 01 - General Requirements" form a part of this Section by this reference thereto, and shall have the same force and effect as if printed herewith in full.

B. Work Included:

1. Type A, Flexible Glass Wool Blanket
2. Type B, Duct Liner
3. Type C, Rigid Glass Wool Board
4. Type E, Fire Protection Duct Wrap
5. Type F, Closed-Cell Polyisocyanurate Rigid Foam Board
6. Type 1, Glass Wool Pipe Insulation
7. Type 2, Flexible Elastomeric Pipe Insulation
8. Jacketing
9. Accessories
10. Duct Insulation Accessories
11. Duct Insulation Compounds
12. Outdoor Ducting Cover

1.2 RELATED SECTIONS

- A. Contents of Division 23, HVAC and Division 01, General Requirements apply to this Section.

1.3 REFERENCES AND STANDARDS

- A. References and Standards as required by Section 23 00 00, HVAC Basic Requirements and Division 01, General Requirements.
- B. In addition, meet the following:

1. Piping and duct insulation products to contain less than 0.1 percent by weight PBDE in all insulating materials.

1.4 SUBMITTALS

- A. Submittals as required by Section 23 00 00, HVAC Basic Requirements and Division 01, General Requirements.
- B. In addition, provide:
 1. Installer qualifications.
 2. Product Data: Identify thermal conductivity, thickness, and jackets (both factory and field applied, if any) for each type of product indicated.
 3. Material Test Reports: From a qualified testing agency acceptable to authorities having jurisdiction indicating, interpreting, and certifying test results for compliance of insulation materials, sealers, attachments, cements, and jackets with requirements indicated. Include dates of tests.
 4. Installer Certificates: Signed by the Contractor certifying that installers comply with requirements.
 5. Submit manufacturer's installation instructions.

1.5 QUALITY ASSURANCE

- A. Quality assurance as required by Section 23 00 00, HVAC Basic Requirements and Division 01, General Requirements.
- B. In addition, meet the following:
 1. Formaldehyde Free: Should be third-party certified with UL Environment Validation.
 2. Recycled Content: A minimum of 40 percent post-consumer recycled glass content certified and UL validated.
 3. Low Emitting Materials: For all thermal and acoustical applications of Glass Mineral Wool Insulation products, provide materials complying with the testing and products requirements of UL GREENGUARD Gold Certification.
 4. Installer to have minimum 5 years' experience in the business of installing insulation.

1.6 WARRANTY

- A. Warranty of materials and workmanship as required by Section 23 00 00, HVAC Basic Requirements and Division 01, General Requirements.

1.7 FIRE HAZARD CLASSIFICATION

- A. Maximum fire hazard classification of the composite insulation construction as installed to be not more than a Flame Spread Index (FSI) of 25 and Smoke Developed Index (SDI) of 50 as tested by current edition of ASTM E84 (NFPA 255) method.
- B. Test pipe insulation in accordance with the requirements of current edition of UL "Pipe and Equipment Coverings R5583 400 8.15".
- C. Test duct insulation in accordance with current edition of ASTM E84, UL 723, NFPA 255, NFPA 90A and NFPA 90B.

PART 2 - PRODUCTS

2.1 TYPE A, FLEXIBLE GLASS WOOL BLANKET

- A. Acceptable Manufacturers:
 - 1. Certainteed
 - 2. Johns Manville
 - 3. Knauf
 - 4. Owens-Corning
- B. ASTM C553, Type 1, Class B-2; flexible blanket.
- C. 'K' Value: 0.27 BTU*in/(hr*sf°F) at 75 degrees F installed, maximum service temperature: 250 degrees F.
- D. Density: 0.75 pounds per cubic foot.
- E. DBDE-free. UL/E validated to be formaldehyde-free.
- F. Vapor Barrier Jacket: FSK aluminum foil reinforced with glass wool yarn and laminated to fire resistant Kraft, secured with UL listed pressure sensitive tape or outward clinched expanded staples and vapor barrier mastic as needed.

2.2 TYPE B, DUCT LINER

- A. Acceptable Manufacturers:
 - 1. Certainteed
 - 2. Johns Manville
 - 3. Knauf
 - 4. Owens-Corning
- B. ASTM C1071; flexible blanket.

- C. 'K' Value: ASTM C518, 0.25 BTU*in/(hr*sf°F) at 75 degrees F, maximum service temperature: 250 degrees F.
- D. Noise Reduction Coefficient: 0.65 or higher based on ASTM C 423 "Type A mounting."
- E. Maximum Velocity on Mat or Coated Air Side: 5,000 FPM.
- F. Adhesive: UL listed waterproof type.
- G. Fasteners: Duct liner galvanized steel pins, welded or mechanically fastened.
- H. Erosion-Resistant Surfaces: UL 181.
- I. ASTM G21 and ASTM G22 Microbial Growth Resistance.
- J. UL GREENGUARD Certified does not support the growth of mold, fungi, or bacteria per ASTM C 1338 and meets UL Environment GREENGUARD Microbial Resistance Listing per UL 2824-"GREENGUARD Certification Program Method for Measuring Microbial Resistance". DBDE-free. UL/E validated to be formaldehyde-free.

2.3 TYPE C, RIGID GLASS WOOL BOARD

- A. Acceptable Manufacturers:
 - 1. Certainteed
 - 2. Johns Manville
 - 3. Knauf
 - 4. Owens-Corning
- B. ASTM C612; rigid board.
- C. 'K' Value: 0.23 BTU*in/(hr*sf°F) at 75 degrees F.
- D. Density: 3.0 pounds per cubic foot.
- E. Vapor Retardant Jacket: AP, bleached Kraft paper bonded to aluminum foil, reinforced with glass wool yarn; or FSK aluminum foil reinforced with glass wool yarn and laminated to fire resistant Kraft, secured with UL listed pressure sensitive tape or outward clinched expanded staples and vapor barrier mastic as needed.

2.4 TYPE D, FLEXIBLE ELASTOMERIC DUCT INSULATION

- A. Acceptable Manufacturers:
 - 1. Armacell LLC Armaflex
 - 2. Or approved equivalent.

- B. Elastomeric Foam: ASTM C534; flexible, cellular elastomeric, molded or sheet.
 - 1. Thermal Conductivity Value: 0.28 BTU*in/(hr*sf°F) at 75 degrees F.
 - 2. Maximum Service Temperature of 220 degrees F.
 - 3. Maximum Flame Spread: 25.
 - 4. Maximum Smoke Developed: 50 (1-inch thick and below).
 - 5. Connection: Waterproof vapor retarder adhesive as needed.
 - 6. UV Protection: UV outdoor protective coating as needed per manufacturer's requirements.
 - 7. Vapor Barrier Jacket for use in ceiling return air plenums: FSK aluminum foil reinforced with glass wool yarn and laminated to fire resistant Kraft, secured with UL listed pressure sensitive tape or outward clinched expanded staples and vapor barrier mastic as needed.
- C. Glue: Contact adhesive specifically manufactured for cementing flexible elastomeric foam.

2.5 TYPE E, FIRE PROTECTION DUCT WRAP

- A. Acceptable Manufacturers:
 - 1. Firemaster
 - 2. Unifrax
 - 3. 3M
- B. Firemaster: Thermal Ceramics "Firemaster" duct wrap ceramic wool blanket, minimum 3-inch thickness, ASTM E119, 2-hour rated assembly.
- C. Fyrewrap: Unifrax "Fyrewrap" duct wrap glass wool blanket, 1.5-inch thickness for 1-hour rated assembly, 3-inch thickness for 2-hour rated assembly. ASTM E-1119.
- D. Grease Ducts not enclosed in rated shaft: 3M Fire Barrier duct wrap 615+, compliant with UL1978, AC101 and ASTM 2336, foil encapsulated.

2.6 TYPE F, CLOSED-CELL POLYISOCYANURATE RIGID FOAM BOARD

- A. Acceptable Manufacturers:
 - 1. Johns Manville
 - 2. Certaineed
 - 3. Knauf

4. RMax
- B. ASTM C1289, Type 1, Class 1.
- C. Thermal Conductivity: 0.16 BTU*in/(hr*sf°F).
- D. Service Temperature: -100 degrees F to 250 degrees F.
- E. Jacketing: 0.024-inch thick multi-layered laminate with tensile strength of 187 lb/inch, puncture resistance of 68 pounds per ASTM D1000, emittance of 0.03 per ASTM C1371, WVTR of 0.00 perm per ASTM E96, and service temperature of -94 degrees F to 248 degrees F, as manufactured by 3M, VentureClad1579GCW-E, or approved equivalent.

2.7 TYPE 1, GLASS WOOL PIPE INSULATION

- A. Acceptable Manufacturers:
 1. Certainteed
 2. Johns Manville
 3. Knauf
 4. Owens-Corning
- B. Glass Wool: ASTM C547 Type I and IV; rigid molded, noncombustible.
 1. Thermal Conductivity Value: As indicated in the insulation tables below.
 2. Maximum Service Temperature: 850 degrees F to 1000 degrees F.
- C. Vapor Retarder Jacket: White Kraft paper reinforced with glass wool and bonded to aluminum foil, secure with self-sealing longitudinal laps and butt strips or vapor barrier mastic.

2.8 TYPE 2, FLEXIBLE ELASTOMERIC PIPE INSULATION

- A. Acceptable Manufacturers:
 1. Insulation:
 - a. Armacell LLC Armaflex
 - b. K-Flex
 - c. Or approved equivalent.
 2. Glue:
 - a. Armacell LLC Armaflex Low VOC Adhesive

- b. K-Flex
 - c. Or approved equivalent.
 - 3. Paint:
 - a. Armacell LLC Armaflex
 - b. K-Flex
 - c. Or approved equivalent.
- B. Elastomeric Foam: ASTM C534; flexible, cellular elastomeric, molded or sheet.
 - 1. Thermal Conductivity Value: As indicated in the insulation tables below.
 - 2. Maximum Service Temperature of 220 degrees F.
 - 3. Maximum Flame Spread: 25.
 - 4. Maximum Smoke Developed: 50 (1-inch thick and below).
 - 5. Vapor Retarder Jacket, for over 1-inch insulation thickness: White Kraft paper reinforced with glass wool and bonded to aluminum foil, secure with self-sealing longitudinal laps and butt strips or vapor barrier mastic.
 - 6. Connection: Waterproof vapor retarder adhesive as needed.
 - 7. UV Protection: UV outdoor protective coating per manufacturer's requirements.
- C. Glue: Contact adhesive specifically manufactured for cementing flexible elastomeric foam.
- D. Paint (for exterior insulation only): Nonhardening high elasticity type, specifically manufactured as protective covering of flexible elastomeric foam insulation for prevention of degradation due to exposure to sunlight and weather.

2.9 TYPE 3, CALCIUM SILICATE

- A. Acceptable Manufacturers:
 - 1. IIG (Industrial Insulation Group)
 - 2. Or approved equivalent.
- B. Hydrous calcium silicate, tested in accordance with ASTM C533 Type I with minimum of 1200 PSI at 5 percent compression. Field applied jacket, Class II. Maximum 1200 degrees F temperature limit. Thermal conductivity as indicated in the insulation tables below.

2.10 TYPE 4, CELLULAR GLASS

- A. Acceptable Manufacturers:
 - 1. Pittsburgh Corning
 - 2. Or approved equivalent.
- B. Cellular Glass Insulation: Foamglass pipe insulation fabricated in accordance with ASTM C552 and C585. Thermal conductivity as indicated in the insulation tables below.

2.11 TYPE 5, GLASS MINERAL WOOL EQUIPMENT INSULATION

- A. Acceptable Manufacturers:
 - 1. Certainteed
 - 2. Johns Manville
 - 3. Knauf
 - 4. Owens-Corning
- B. Flexible Glass Mineral Wool Blanket: ASTM C612; flexible.
 - 1. Thermal Conductivity Value: As indicated in the insulation tables below.
 - 2. Maximum Service Temperature: 450 degrees F.

2.12 JACKETING

- A. Acceptable Manufacturers:
 - 1. ITW Insulation Systems
 - 2. General Insulation Company
 - 3. 3M
 - 4. Or approved equivalent.
- B. Insulation Jacketing and Insulation Jacketing Tape for Ductwork and Piping: 0.024-inch thick multi-layered laminate with tensile strength of 187 lb/inch, puncture resistance of 68 pounds per ASTM D1000, emittance of 0.03 per ASTM C1371, WVTR of 0.00 perm per ASTM E96, and service temperature of -94 degrees F to 248 degrees F, as manufactured by 3M, VentureClad1579GCW-E, or approved equivalent.
- C. PVC preformed molded insulation covers, for piping. Zeston or approved equivalent.
- D. Stainless Steel Jacket: Type 304 stainless steel, 0.010-inch, smooth finish.

2.13 ACCESSORIES

- A. Acceptable Manufacturers:
 - 1. ITW Insulation Systems
 - 2. Or approved equivalent.
- B. Equipment Insulation Jacketing: Presized glass cloth, not less than 7.8 ounces/sq.yd., except as otherwise indicated. Coat with gypsum based cement.
- C. Equipment Insulation Compounds: Provide adhesives, cement, sealers, mastics and protective finishes as recommended by insulation manufacturer for applications indicated.
- D. General: Provide staples, bands, wire, wire netting, tape corner angles, anchors, stud pins and metal covers as recommended by insulation manufacturer for applications indicated. Accessories, i.e., adhesives, mastics, cements and tape to have the same flame and smoke component ratings as the insulation materials with which they are used. Shipping cartons to bear a label indicating that flame and smoke ratings do not exceed those listed above. Provide permanent treatment of jackets or facings to impart flame and smoke safety. Provide non-water-soluble treatments. Provide UV protection recommended by manufacturer for outdoor installation.

2.14 DUCT INSULATION ACCESSORIES

- A. Acceptable Manufacturers:
 - 1. Certainteed
 - 2. Johns Manville
 - 3. Owens-Corning
- B. Staples, bands, wires, tape, anchors, corner angles and similar accessories as recommended by insulation manufacturer for applications indicated.

2.15 DUCT INSULATION COMPOUNDS

- A. Acceptable Manufacturers:
 - 1. Certainteed
 - 2. Johns Manville
 - 3. Owens-Corning
- B. Cements, adhesives, coatings, sealers, protective finishes and similar accessories as recommended by insulation manufacturer for applications indicated. Comply with South Coast Air Quality Management District (SCAQMD) Rule #1168 in accordance with LLE EQ 4.1.

2.16 OUTDOOR DUCTING COVER

- A. Acceptable Manufacturers:
 - 1. 3M
 - 2. Certainteed
 - 3. Johns Manville
 - 4. Owens-Corning
- B. Aluminum Jacket: 0.024-inch thick multi-layered laminate with tensile strength of 187 lb/inch, puncture resistance of 68 pounds per ASTM D1000, emittance of 0.03 per ASTM C1371, WVTR of 0.00 perm per ASTM E96, and service temperature of -94 degrees F to 248 degrees F, as manufactured by 3M, VentureClad1579GCW-E, or approved equivalent, with longitudinal slip joints and 3-inch laps.
- C. UV resistant polyvinyl chloride covering with joints secured and sealed.

PART 3 - EXECUTION

3.1 GENERAL INSTALLATION REQUIREMENTS

- A. Verification of Conditions:
 - 1. Do not apply insulation until pressure testing and inspection of ducts and piping has been completed.
 - 2. Examine areas and conditions under which duct and pipe insulation will be installed. Do not proceed with work until unsatisfactory conditions have been corrected.
- B. Preparation: Clean and dry surfaces to be insulated.
- C. Installation:
 - 1. Insulation: Continuous through walls, floors and partitions except where noted otherwise.
 - 2. Piping and Equipment:
 - a. Install insulation over clean, dry surfaces with adjoining sections firmly butted together and covering surfaces. Fill voids and holes. Seal raw edges. Install insulation in a manner such that insulation may be split, removed, and reinstalled with vapor barrier tape on strainer caps and unions. Do not install insulation until piping has been leak tested and has passed such tests. Do not insulate manholes, equipment manufacturer's nameplates, handholes, and ASME stamps. Provide beveled edge at such insulation interruptions. Repair voids or tears.

- b. Cover insulation on pipes above ground, outside of building, with aluminum jacketing. Position seam on bottom of pipe.
- D. Cover insulation on exposed refrigerant piping above ground, outside of building with heavy duty multi-layered laminated jacketing tape. Position seams on bottom of pipe. Use Venture Tape VentureClad Plus 1579GCW-E or approved equal.
- E. Provide accessories as required. See Part 2 Article "Accessories" above.
- F. Protection and Replacement: Installed insulation during construction. Replace damaged insulation which cannot be repaired satisfactorily, including units with vapor barrier damage and moisture saturated units.
- G. Labeling and Marking: Provide labels, arrows and color on piping and ductwork. Attach labels and flow direction arrows to the jacketing per Section 23 05 53, Identification for HVAC Piping, Ductwork and Equipment.
- H. Ductwork:
 - 1. Install insulation in conformance with manufacturer's recommendations to completely cover duct.
 - 2. Butt insulation joints firmly together and install jackets and tapes smoothly and securely.
 - 3. Apply duct insulation continuously through sleeves and prepared openings, except as otherwise specified. Apply vapor barrier materials to form complete unbroken vapor seal over insulation.
 - 4. Coat staples and seals with vapor barrier coating.
 - 5. Cover breaks in jacket materials with patches of same material as vapor barrier. Extend patches not less than 3-inches beyond break or penetration on all directions and secure with adhesive and staples. Seal staples and joints with vapor barrier coating.
 - 6. Fill jacket penetrations. i.e., hangers, thermometers and damper operating rods, and other voids in insulation with vapor barrier coating. Seal penetration with vapor barrier coating. Insulate hangers and supports for cold duct in un-conditioned spaces to extent to prevent condensation on surfaces.
 - 7. Seal and flash insulation terminations and pin punctures with reinforced vapor barrier coating.
 - 8. Continue insulation at fire dampers and fire/smoke dampers up to and including those portions of damper frame visible at outside of the rated fire barrier. Insulating terminations at fire dampers in accordance with this Section.

9. Do not conceal duct access doors with insulation. Install insulation terminations at access door in accordance with this Section.
- I. Insulated Pipe Exposed to Weather: Where piping is exposed to weather, cover insulation with aluminum jacket. Seal watertight jacket per manufacturer's recommendations. Install metal jacket with 2-inch overlap at longitudinal and butt joints with exposed lap pointing down. Secure jacket with stainless-steel draw bands 12-inches on center and at butt joints.
- J. Insulation Shields: Provide hangers and shields (18 gauge minimum) outside of insulation for cold piping (<60 degrees F). Hot water piping hangers may penetrate insulation to contact pipe directly. Provide 18-inch long, noncompressible insulation section at insulation shields for lines 2-inches and larger (hot and cold) piping.
- K. Ductwork Surfaces to be Insulated:

Item to be Insulated	System Insulation Type	Duct Size	Insulation Thickness
Supply ductwork where duct is not specified to be lined.	A	All	1.5-inch
Return ductwork where duct is not specified to be lined.	--	All	None
Supply ductwork (located outside building thermal envelope)	A (for round ductwork) F (for rectangular ductwork)	All	3-inch (for round ductwork) 1.5-inch (for rectangular ductwork)
Return ductwork (located outside building thermal envelope)	A (for round ductwork) F (for rectangular ductwork)	All	3-inch (for round ductwork) 1.5-inch (for rectangular ductwork)
Duct Silencers	C	All	1.5-inch
Outside Air Ducts	A	All	3-inch
HVAC plenums and unit housings not preinsulated	B	All	1.5-inch
Grease Exhaust	E	All	Per rating level

Exhaust ducts within 10-feet of exterior	A	All	3-inch
Exposed insulation in mechanical rooms or areas subject to damage	C, D	All	1.5-inch

1. Note: Insulation thickness shown is a minimum. If commonwealth codes require additional thickness, then provide insulation thickness per code requirements.

L. Piping Surfaces to be Insulated:

Item to be Insulated	System Insulation Type	Conductivity Range (Btu-inch per hour per SF per degrees F)	Pipe Size (Inches)	Insulation Thickness (Inches)
Heating, Steam, and Steam Condensate (above 350F)	1, 4	0.32-0.34 at a mean rating temperature of 250 degrees F	<1	4.5
			1 to <1.5	5.0
			1.5 to <4	5.0
			4 to <8	5.0
			>= 8	5.0
Heating, Steam, and Steam Condensate (251F to 350F)	1, 4	0.29-0.32 at a mean rating temperature of 200 degrees F	<1	3.0
			1 to <1.5	4.0
			1.5 to <4	4.5
			4 to <8	4.5
			>= 8	4.5
Heating, Steam, and Condensate (201F to 250F)	1, 4	0.27-0.30 at a mean rating temperature of 150 degrees F	<1	2.5
			1 to <1.5	2.5
			1.5 to <4	2.5
			4 to <8	3.0

			>= 8	3.0
Heating, Steam, and Steam Condensate (141F to 200F)	1, 4	0.25-0.29 at a mean rating temperature of 125 degrees F	<1 1 to <1.5 1.5 to <4 4 to <8 >= 8	1.5 1.5 2.0 2.0 2.0
Heating, Steam, and Steam Condensate (105F to 140F)	1, 4	0.21-0.28 at a mean rating temperature of 100 degrees F	<1 1 to <1.5 1.5 to <4 4 to <8 >= 8	1.0 1.0 1.5 1.5 1.5
Chilled Water (40F to 60F)	1, 4	0.21-0.27 at a mean rating temperature of 75 degrees F	<1 1 to <1.5 1.5 to <4 4 to <8 >= 8	0.5 0.5 1.0 1.0 1.0
Chilled Water (<40F)	1, 4	0.20-0.26 at a mean rating temperature of 50 degrees F	<1 1 to <1.5 1.5 to <4 4 to <8 >= 8	0.5 1.0 1.0 1.0 1.5
Refrigerant Suction and Liquid Piping (40F to 60F)	2	0.21-0.27 at a mean rating temperature of 75 degrees F	<1 1 to <1.5 1.5 to <4 4 to <8	0.5 0.5 1.0 1.0

			>= 8	1.0
Refrigerant Suction and Liquid Piping (<=40F)	2	0.20-0.26 at a mean rating temperature of 50 degrees F	<1 1 to <1.5 1.5 to <4 4 to <8 >= 8	0.5 1.0 1.0 1.0 1.5
Refrigerant Hot Gas Piping for VRF Systems	2	0.20-0.26 at a mean rating temperature of 50 degrees F	All	0.5
Breeching, Generator Exhaust	3	0.52-0.58 at a mean rating temperature of 500 degrees F	All	4.0
Heating Water Storage and Air Separation Tanks	2, 5	0.24-0.28 at a mean rating temperature of 75 degrees F	N/A	2.0
Chilled Water Storage and Air Separation Tanks	2, 5	0.24-0.28 at a mean rating temperature of 75 degrees F	N/A	1.0
Heat Exchangers (Steam)	2, 5	0.24-0.28 at a mean rating temperature of 75 degrees F	N/A	4.0
Heat Exchangers (Hydronic)	2, 5	0.24-0.28 at a mean rating temperature	N/A	2.0

		of 75 degrees F		
Condenser Water (Exterior)	1, 2, aluminum jacketing	0.21-0.27 at a mean rating temperature of 75 degrees F	1 to 6 >=8	1.0 1.5

- Note: Insulation thickness shown is a minimum. If commonwealth code requires additional thickness, then provide insulation thickness per code requirements.

3.2 TYPE A, FLEXIBLE GLASS WOOL BLANKET

- Install insulation in conformance with manufacturer's recommendations and requirements.
- Duct Wrap: Cover air ducts per insulation table except ducts internally lined where internal duct lining is adequate to achieve adequate insulating values to meet local Energy Codes (indicate on shop drawings, locations where duct wrap is planned to be omitted and indicate internal duct lining insulating values to confirm they will meet the Energy Code.) Wrap tightly with circumferential joints butted and longitudinal joints overlapped minimum of 2-inches. On ducts over 24-inches wide, additionally secure insulation with suitable mechanical fasteners at 18-inches on center. Circumferential and longitudinal joints stapled with flare staples 6-inches on center and covered with 3-inch wide, foil reinforced tape.

3.3 TYPE B, DUCT LINER

- Install insulation in conformance with manufacturer's recommendations and requirements.
- Duct Liners: Mat finish surface on air stream side. Secure insulation to cleaned sheet metal duct with continuous (minimum 90) percent coat of adhesive. Secure liner with mechanical fasteners 15-inches on center or per manufacturer requirements. Accurately cut liner and thoroughly coat ends with adhesive. Butt joints tightly. Top and bottom sections of insulation overlap sides. Factory/field coat exposed edges. Metal nosing for exposed leading or transverse edges and when velocity exceeds 3500 FPM or manufacturer rating on exposed edges. Keep duct liner clean and free from dust. At completion of Project, vacuum duct liner if it is dirty or dusty. Do not use small pieces. If insulation is installed without horizontal, longitudinal, and end joints butted together, installation will be rejected and work removed and replaced with work that conforms to this Specification.

3.4 TYPE C, RIGID GLASS WOOL BOARD

- Install insulation in conformance with manufacturer's recommendations and requirements.

3.5 TYPE E, FIRE PROTECTION DUCT WRAP

- Install insulation in conformance with manufacturer's recommendations and requirements.

- B. Coordinate layers of wrap and thickness with required enclosure rating.
- C. Minimum 3-inch overlap required on joints.
- D. Cut edges and joints sealed with aluminum foil tape.
- E. Install according to manufacturer's recommendations to maintain UL installation requirements.
- F. Provide manufacturer's insulation system over duct access doors without impeding access.
- G. Provide fire wrap on makeup air duct connections to hood within 18-inches of combustible construction.

3.6 TYPE F, CLOSED-CELL POLYISOCYANURATE RIGID FOAM BOARD

- A. Install insulation in conformance with manufacturer's recommendations and requirements.

3.7 TYPE 1, GLASS WOOL PIPE INSULATION

- A. See General Installation Requirements above.
- B. Install insulation in conformance with manufacturer's recommendations and requirements.
- C. Lap seal insulation with waterproof adhesive. Do not use staples or other methods of attachment which would penetrate vapor barrier. Apply fitting covers with seated tacks and vapor barrier tape.
- D. Apply insulation to pipe and seal with self-sealing lap. Use self-sealing butt strips to seal butt joints. Insulate fittings, valves and unions with single or multiple layers of insulation and cover to match pipe or use preformed PVC molded insulation covers.

3.8 TYPE 2, FLEXIBLE ELASTOMERIC PIPE INSULATION

- A. Flexible Elastomeric Insulation:
 - 1. Slip insulation on pipe prior to connection. Butt joints sealed with manufacturer's adhesive. Insulate fitting with miter-cut pieces. Cover insulation exposed to weather and below grade with two coats of finish as recommended by manufacturer.
- B. Flexible Elastomeric Tubing:
 - 1. Flexible Elastomeric Tubing: Slip insulation over piping or, if piping is already installed, slit insulation and snap over piping. Joints and butt ends must be adhered with 520 adhesive.
- C. See General Installation Requirements above.
- D. Install insulation in conformance with manufacturer's recommendations and requirements.

- E. Slip insulation on pipe prior to connection. Butt joints sealed with manufacturer's adhesive. Insulate fitting with miter-cut pieces. Cover insulation exposed to weather and undergrade with two coats of finish as recommended by manufacturer.
- F. Install in accordance with manufacturer's instructions for below grade installation.

3.9 JACKETING

- A. See General Installation Requirements above.
- B. Install in accordance with manufacturer's instructions.

3.10 ACCESSORIES

- A. Install insulation in conformance with manufacturer's instructions, recommendations and requirements.
- B. See General Installation Requirements above.
- C. Furnish and install accessories for all insulation types listed in this Section.

3.11 DUCT INSULATION ACCESSORIES

- A. Install insulation in conformance with manufacturer's recommendations and requirements.

3.12 DUCT INSULATION COMPOUNDS

- A. Install insulation in conformance with manufacturer's recommendations and requirements.

3.13 OUTDOOR DUCTING COVER

- A. Install insulation in conformance with manufacturer's recommendations and requirements.
- B. Outdoor Duct Exposed to Weather:
 - 1. Install jacket with brakes/slope to prevent standing water on duct. Use weatherable components.
 - 2. Weatherproof seal at joints and seams. Minimum 3-inch overlap.
 - 3. Label jacket every 6-feet and within 2-feet of building penetrations and equipment connections: "Do not stand or place equipment on duct."

END OF SECTION 230700

SECTION 321400

UNIT PAVING

PART 1 – GENERAL

1.1 SUMMARY

A. Stipulations

1. The specifications sections “General Conditions to the Construction Contract”, “Special Conditions” and “Division 01 - General Requirements” form a part of this Section by this reference thereto, and shall have the same force and effect as if printed herewith in full.

B. General: Provide Unit Paving in accordance with requirements of the Contract Documents.

C. Section Includes the Following:

1. PAV-01: Concrete Pavers at Grade
2. PAV-02: Concrete Pavers at Grade
3. PAV-03: Concrete Pavers
4. PAV-04: Concrete Pavers at Grade

D. Related Requirements:

1. Division 3 Concrete
2. Section 32 43 00- Landscape Stone Masonry
3. Section 07 92 00- Joint Sealants
4. Section 12 93 00- Site Furnishings
5. Section 32 84 00- Planting Irrigation
6. Section 32 93 00- Planting

1.2 REFERENCES

A. American Society for Testing and Materials (ASTM):

1. ASTM A153: Zinc Coating (Hot-Dip) on Iron and Steel Hardware.
2. ASTM A307: REV A-88: Carbon Steel Threaded Standard Fasteners.
3. ASTM C5: Quicklime for Structural Purposes.
4. ASTM C91: Masonry Cement.
5. ASTM C97: Absorption and Bulk Specific Gravity of Natural Building Stone.
6. ASTM C144: Aggregate for Masonry Mortar.
7. ASTM C150: Portland Cement.
8. ASTM C170: Compressive Strength of Natural Building Stone.
9. ASTM C207: Hydrated Lime for Masonry Purposes.
10. ASTM C217: Weather Resistance of Slate (for quartzite).
11. ASTM C241: Abrasion Resistance to Stone Subjected to Foot Traffic.

12. ASTM C295: Guide for Petrographic Examination of Aggregates for Concrete.
13. ASTM C880: Test Method for Flexural Strength of Dimensional Stone.
14. ASTM C503: Marble Building Stone.

1.3 SUBMITTALS

- A. Submit in accordance with the requirements of Division 01, Submittal Procedures and the following:
 1. Product Data:
 - a. Include data on physical properties required by referenced ASTM standards.
 - b. Pavers, accessories and other manufactured products.

- B. Paver Samples for Verification: Submit 5 sets for color, grade, finish, and variety of pavers required;
 1. Submit 2 samples of each paving stone type in a size not less than 12 inches by 12 inches by the specified thickness for each color, grade and finish of stonework required; provide specified finish on (1) face of each sample.
 2. The samples, when reviewed and marked No Exceptions Taken, by the Professional will be considered the project control samples.
 3. Maintain and protect one full set of approved samples at the Department's construction office for the duration of the Project.

- C. Shop Drawings: Show plans, sections, and details for each location indicating details of installation and adjacencies of other work.
 1. At contractor's request, within 30 days of award of contract, Professional will provide electronic ACAD drawings for coordination, layout, and detailing of stone paving features. Electronic files are provided for contractor convenience in production of shop drawings. In using electronic files contractor will agree to stipulations of use as put forward by Professional at time of file transmittal.
 2. Show dimensions and finishes of stone paving.
 3. Include details of mortar joints, sealant joints and expansion joints.
 4. Show locations and details of anchors.

- D. Grout and Sealant: Submit samples for verification of Custom Grout and Sealant in accordance with requirements under Sections 07 9200 Joint Sealants, submit samples for each type and color of grout and sealant required.

1.4 QUALITY ASSURANCE

- A. Manufacturer's Qualifications: Not less than 5 years experience in the actual production of specified products.

- B. **Installer's Qualifications:** In order to qualify for the work on this project, Trade Contractor must submit the following information for review and approval.:
1. Installer must be experienced in application or installation of work and exterior unit paving similar in complexity to that required for this Project.
 2. Installer must be acceptable to or licensed by manufacturer.
 3. Not less than 5 year experience with exterior unit paving.
 4. Successfully completed not less than 4 projects, reasonably comparable in scale, and references from Departments or Professionals of same.
- C. **Source Limitations:** Obtain each type of unit paver, setting pedestals and spacers from one source with resources to provide materials and products of consistent quality in appearance and physical properties.
- D. **Source Limitations for Other Materials:** Obtain each type of cementitious material, grout, admixture, stone accessory, sealant, and other material from a single manufacturer.
- E. **Preconstruction Compatibility and Adhesion Testing:** Submit to latex-additive manufacturer, for testing indicated below, samples of paving materials that will contact or affect mortar and grout that contain latex additives.
1. Use manufacturer's standard test methods to determine whether mortar and grout materials will obtain optimum adhesion with and will be non-staining to, installed pavers and other materials constituting a complete paver installation.
- F. **Mock-ups:** Following approval of samples submitted and in accordance with final approved shop drawings, the Contractor shall construct a 5' x 5' sample panel for each stone type. Build mock-ups to demonstrate aesthetic effects and set quality standards for materials and execution.
1. Construct mock-ups that accurately represent all materials, jointing, and any other elements of the finished assembly.
 2. Where paving is adjacent to stone veneer edge include veneer edge assembly into mock-up.
 3. Include expansion joint.
 4. Correct areas, modify method of application/installation, or adjust finish texture as directed by Professional to comply with specified requirements.
 5. Approval of mock-ups does not constitute approval of deviations from the Contract Documents unless Professional specifically approves such deviations in writing.
 6. Refinish mock-up area as required to produce acceptable work.
 7. Approved mock-ups may become part of the completed work if properly protected and undisturbed at time of Substantial Completion.
- G. **Pre-Installation Conference:** Conduct a pre-installation conference in accordance with Division 01 Project Management and Coordination.

1.5 DELIVERY, STORAGE, AND HANDLING

- A. Store pavers on elevated platforms in a dry location. If units are not stored in an enclosed location, cover tops and sides of stacks with waterproof sheeting, securely tied.
- B. Store cementitious materials on elevated platforms, under cover, and in a dry location. Do not use cementitious materials that have become damp.
- C. Deliver pre-blended, dry mortar mix in moisture-resistant containers designed for lifting and emptying into dispensing silo. Store pre-blended, dry mortar mix in delivery containers on elevated platforms, under cover, and in a dry location or in a metal dispensing silo with weatherproof cover.
- D. Store masonry accessories, including metal items, to prevent corrosion and accumulation of dirt and oil.
- E. Store aggregates where grading and other required characteristics can be maintained and contamination avoided.
- F. Store liquids in tightly closed containers protected from freezing.
- G. Store asphalt cement and other bituminous materials in tightly closed containers.

1.6 PROJECT CONDITION

- A. Cold-Weather Protection: Do not use frozen materials or materials mixed or coated with ice or frost. Do not build on frozen subgrade or setting beds. Remove and replace stone paving work damaged by frost or freezing. Do not build on frozen subgrade or setting beds.
- B. Protection of Paving: During construction, cover tops of walls, projections, and sills with waterproof sheeting at end of each day's work. Cover partially completed stone paving when construction is not in progress.
 - 1. Increase extent of cover in subparagraph below as needed to suit climatic conditions.
 - 2. Extend cover a minimum of 24 inches down both sides and hold cover securely in place.
- C. Stain Prevention: Immediately remove mortar and soil to prevent them from staining the face of paving.
 - 1. Protect base of walls from rain-splashed mud and mortar splatter by coverings spread on the ground and over the wall surface.
 - 2. Protect sills, ledges, and projections from mortar droppings.
 - 3. Protect surfaces of window and door frames, as well as similar products with painted and integral finishes, from mortar droppings.
- D. Cold-Weather Requirements: Do not use frozen materials or materials mixed or coated with ice or frost. Do not build on frozen substrates. Remove and replace stone paving damaged by frost or freezing conditions. Comply with cold-weather construction requirements contained in ACI 530.1/ASCE 6/TMS 602.

1. Cold-Weather Cleaning: Use liquid cleaning methods only when air temperature is 40 deg F and above and will remain so until masonry has dried, but not less than 7 days after completing cleaning.
- E. Hot-Weather Requirements: Comply with hot-weather construction requirements contained in ACI 530.1/ASCE 6/TMS 602.
- F. Weather Limitations for Mortar and Grout:
1. Cold-Weather Requirements: Protect stone paving work against freezing when ambient temperature is 40 deg F and falling. Heat materials to provide mortar and grout temperatures between 40 and 120 deg F. Provide the following protection for completed portions of work for 24 hours after installation when the mean daily air temperature is as indicated: below 40 deg F, cover with weather-resistant membrane; below 25 deg F, cover with insulating blankets; below 20 deg F, provide enclosure and temporary heat to maintain temperature above 32 deg F.
 2. Hot-Weather Requirements: Protect stone paving work when temperature and humidity conditions produce excessive evaporation of setting beds and grout. Provide artificial shade and windbreaks and use cooled materials as required. Do not apply mortar to substrates with temperatures of 100 deg F and higher.
 3. When ambient temperature exceeds 100 deg F, or when wind velocity exceeds 8 mph and ambient temperature exceeds 90 deg F, set stone paving within 1 minute of spreading setting-bed mortar.

1.7 WARRANTY

- A. At project closeout provide to the Department or Departments Representative an executed copy of the manufacturer's standard document outlining the terms, conditions and limitations of their limited warranty against manufacturing defect for a period of three (3) years.
- B. The Contractor warrants that his work will remain free from defects of labor and materials used in conjunction with his work in accordance with the General Conditions for this project or a maximum of three (3) years.
- C. It is the responsibility of the Contractor installing the product listed in this section to coordinate warranty requirements with any related sections or adjacent Work. Notify the Professional immediately of any potential lapses or limitations in warranty coverage.

PART 2 - PRODUCTS

2.1 PAV-01, PAV-02, PAV-03, PAV-04 – CONCRETE PAVERS:

A. Manufacturer:

1. UNILOCK

51 International Blvd
Brewster, NY 10509
<https://unilock.com/>

2. Hanover Professionalural Products

5000 Hanover Road
Hanover, PA 17331
voice : (717) 637-0500
toll free : (800) 426-4242
fax : (717) 637-7145
<http://www.hanoverpavers.com>

3. Nitterhouse Masonry Products, LLC

859 Cleveland Avenue
Chambersburg, PA 17201
Phone (717) 268-4137
Fax (717) 267-4585
masonry@nitterhouse.com

B. Product: As noted on drawings

C. Color: As noted on drawings

D. Finish: As noted on drawings

E. Size: As noted on drawings

2.2 — GRATE DRAIN COVER

A. ~~Manufacturer: Ironage~~

~~2104 SW 152nd St. Suite #4~~

~~Burien, WA 98166~~

~~info@ironagegrates.com~~

1. ~~Product: See material schedule~~

2. ~~Size: As noted on drawings~~

3. ~~Material: As noted on drawings~~

4. ~~Finish: As noted on drawings~~

2.3 — PAVING AREA DRAIN COVER

A. ~~Manufacturer: Ironage~~

~~2104 SW 152nd St. Suite #4~~

~~Burien, WA 98166~~

~~info@ironagegrates.com~~

1. ~~Product: See material schedule~~
2. ~~Size: As noted on drawings~~
3. ~~Material: As noted on drawings~~
4. ~~Finish: As noted on drawings~~

2.4 MORTAR MATERIALS

- A. Portland Cement: ASTM C 150, Type I or II. Provide natural color or white cement as required to produce mortar color indicated.
 1. Low-Alkali Cement: Not more than 0.60 percent total alkali when tested according to ASTM C 114.
- B. Hydrated Lime: ASTM C 207, Type S.
- C. Portland Cement-Lime Mix: Packaged blend of portland cement complying with ASTM C 150, Type I or II, and hydrated lime complying with ASTM C 207.
- D. Mortar Cement: ASTM C 1329.
- E. Masonry Cement: ASTM C 91.

2.5 CONCRETE SAND

- A. Concrete Sand for paver joints and setting bed shall comply with ASTM C 33 Specification for Concrete Aggregate.

2.6 SAND CEMENT MIX

- A. The mix shall be 1 part cement to 4 parts concrete sand.

2.7 MORTAR AND GROUT MIXES

- A. Mortar: Comply with referenced standards and with manufacturers' written instructions for mix proportions, mixing equipment, mixer speeds, mixing containers, mixing time, and other procedures needed to produce mortar of uniform quality and with optimum performance characteristics.
 1. Do not use admixtures, including pigments, air-entraining agents, accelerators, retarders, water-repellent agents, antifreeze compounds, or other admixtures, unless otherwise indicated. Do not use calcium chloride.
 2. Combine and thoroughly mix cementitious materials, water, and aggregates in a mechanical batch mixer, unless otherwise indicated. Discard mortar when it has reached initial set.

- B. Latex-Modified Portland Cement Setting Mortar: Proportion and mix portland cement, aggregate, and latex additive to comply with written instructions of latex-additive manufacturer and as necessary to produce stiff mixture with a moist surface when bed is ready to receive stone.
- C. Mortar: Portland Cement-Lime Mix.
 - 1. Packaged blend of portland cement complying with ASTM C 150, Type I or Type II, and hydrated lime complying with ASTM C 207.
- D. Drypack Mortar: Mortar setting bed consisting of one part ASTM C150, Type I/II Portland Cement and three to four parts sand (cement to sand ratio by volume of 1:3 to 1:4 adjusted for climate conditions at time of mixing).
 - 1. Water: Potable.
- E. Latex-Modified Portland Cement Bond Coat: Proportion and mix portland cement, aggregate, and latex additive to comply with latex-additive manufacturer's written instructions.
 - 1. For latex-modified Portland cement setting-bed mortar, substitute latex admixture for part or all of water, according to latex-additive manufacturer's written instructions.
- F. Joint Grout: Comply with mixing requirements of referenced ANSI standards and manufacturer's written instructions.
 - 1. Custom color to be approved by Professional.
- G. Latex Portland Cement Grout: Custom Color mix as selected by Professional to match stone paving. Comply with mixing requirements of referenced ANSI standards and manufacturer's written instructions:
 - 1. C-Cure Corporation.
 - 2. Custom Building Products.
 - 3. Laticrete International, Inc.
 - 4. Mapei Corporation.
 - 5. TEC Specialty Products, Inc.
- H. Water-Cleanable Epoxy Grout for use at Display Panels: ANSI 118.3, non-toxic, non-flammable, non-hazardous during storage, mixing, application and when cured and shall meet the following requirements:
 - 1. Compressive strength: ANSI 118.3 – 3500 psi.
 - 2. Shear bond strength: ANSI 118.3 – 1000 psi.
 - 3. Water absorption: ANSI 118.3 <0.5%.
 - 4. Cured epoxy grout to be chemically and stain resistant to ketchup, mustard, tea, coffee, milk, soda, beer, wine, bleach (5% solution), ammonia, juices, vegetable oil, brine, sugar, cosmetics, and blood, as well as chemically resistant to dilute acids and dilute alkalis.

5. Custom Color as selected by Professional.
6. SpectraLock Pro, by Laticrete International, Inc.
7. Epoxy grout for use at Display Panels as indicated per Drawings.
8. Or approved equivalent.

2.8 MORTAR WELDED WIRE REINFORCEMENT

- A. Welded wire reinforcement for stone paving mortar setting bed shall be stainless steel, 2"x2" mesh x 16 gauge. It shall meet all requirements for this application. It shall conform to ASTM A 1022, ASTM A 1064* , ASTM A 185 and ASTM A 82 as appropriate.

2.9 MORTAR STOPS

- A. Where indicated per Drawings, provide painted carbon steel mortar stops.
 1. Dimension: As indicated per Drawings.
 2. Finish: High performance polyurethane coating. Color to be determined by Professional.

2.10 METAL EDGING

- A. Supplier or approved equal:
 1. Permaloc
13505 Barry Street, Holland, MI 49424
<https://permaloc.com/>
 2. Border Concepts, Inc.
P.O. Box 471185, Charlotte, NC 28247
<https://borderconcepts.com/>
- B. Product: As noted on drawings
- C. Size: As noted on drawings
- D. Material: As noted on drawings
- E. Color: As noted on drawings

2.11 BITUMINOUS SETTING

- A. Asphalt cement to be used in the bituminous setting bed shall conform to ASTM Designation D-946-69A with a penetration at 77 degrees F. 100 G., 5 sec of minimum 3.346 inches and a maximum of 3.937 inches.
- B. The fine aggregate to be used in the bituminous setting bed shall be clean, hard sand with durable particles and free from adherent coatings, lumps of clay, alkali salts and organic matters. It shall be uniformly graded from "coarse" to "fine" and all passing the No. 4 sieve and

meet with gradation requirements when tested in accordance with the standard method of test for sieve and screen analysis for fine and coarse aggregates ASTM Designation C-136-67. The dried fine aggregates shall be combined with hot asphalt cement, and the mix shall be heated to approximately 300 degrees F. at asphalt plant. The appropriate proportion of materials shall be seven (7) percent asphalt cement and ninety-three (93) percent sand by weight in the approximate ratio of 145 pounds asphalt to 1,855 pounds of sand. The contractor shall determine the exact proportions to produce the best possible mixture for construction of the bituminous setting bed to meet construction requirements

C. Neoprene Tack Coat

1. Use Paver Mastic as supplied by Hanover Pavers.

2.12 EPOXY SETTING

A. Manufacturer:

Surebond, Inc.
International Lane
Madison, WI 53704
Tel. 608-237-7554
Fax. 608-237-7558

- B. Product: Paver Bond, SB10, quart containers (contractor grade)

2.13 FABRICATION

- A. Fabricate stone to comply with sizes, shapes, and tolerances recommended by applicable stone association or, if none, by stone source, for faces, edges, beds, and backs.
- B. Cut and Select stone to produce pieces of thickness, size, and shape indicated, including details on Drawings. Dress joints (bed and vertical) straight and at right angle to face unless otherwise indicated.
- C. Cut and drill sinkages and holes in stone for any required anchors and supports.
- D. Finish exposed faces and edges of stone to comply with requirements indicated for finish and to match approved samples and mockups.

PART 3 - EXECUTION

3.1 EXAMINATION

- E. Verify installation conditions as satisfactory to receive work of this Section. Do not install until unsatisfactory conditions are corrected. Beginning work constitutes acceptance of conditions as satisfactory.

3.2 INSTALLATION

- A. Install the work in accordance with “Quality Assurance” provisions, References, Specifications, Drawings, and Manufacturers’ directions.
- B. General:
1. Do not use stone pavers with chips, cracks, voids, discoloration, and other defects that might be visible or cause staining in the finished work.
 2. Use full units without field cutting to greatest extent possible. Where required, cut stone with motor-driven masonry saw equipment with diamond blades to provide clean, sharp, and unchipped edges. All cut lines to be straight and true. Hammer cutting is not acceptable.
 3. Joint pattern: See Drawings for layout pattern.
 4. Set pavers to comply with requirements indicated on Drawings and Shop Drawings. Install anchors, supports, fasteners, pedestals and other attachments indicated or necessary to secure pavers in place. Shim and adjust anchors, supports, and accessories to set stone accurately in locations indicated with uniform joints of widths indicated and with edges and faces aligned according to established relationships and indicated tolerances.
 5. Arrange paver pattern to provide consistent joint work throughout as shown in Drawings.
 6. Expansion and Control Joints: Provide for sealant-filled joints at locations and of widths indicated. Provide foam filler as backing for sealant-filled joints; where unfilled joints are indicated, provide temporary filler until paver installation is complete. Install joint filler before setting pavers. Section 32 1373 “Concrete Paving Joint Sealants”
 7. Identify and confirm with Professional areas of paving to receive different types of mortar and grout as indicated under Part 2 – Products.
- C. Set stone to comply with requirements indicated on Drawings and Shop Drawings. Install anchors, supports, fasteners, and any other attachments indicated or necessary to secure stone coping and veneer in place. Shim and adjust anchors, supports, and accessories to set stone accurately in locations indicated with uniform joints of widths indicated and with edges and faces aligned according to established relationships and indicated tolerances.
- D. Isolation Membrane: Where indicated in Drawings install isolation membrane between topping slab expansion joints and expansion joints in stone paving.
1. Install per manufacturers’ recommendations and requirements.
- E. Mortar Base: Install in conformance with manufacturer’s directions for thick bed, bonded to underlying substrate and the following:
1. Concrete subbase may be damp but no standing water should be present.
 2. Apply mortar-bed bond coat over surface of concrete subbase about 15 minutes before placing setting bed. Limit area of bond coat to avoid its drying out before placing setting bed. Do not exceed 1/16-inch thickness for bond coat.

3. Apply mortar bed over bond coat immediately after applying bond coat. Spread and screed setting bed to uniform thickness at subgrade elevations required for accurate setting of pavers to finished grades indicated.
 4. Place reinforcing wire over concrete subbase, lapped at joints by at least one full mesh and supported so mesh becomes embedded in the middle of setting bed. Hold edges back from vertical surfaces approximately 1/2 inch.
 5. Place mortar bed with reinforcing wire fully embedded in middle of setting bed. Spread and screed setting bed to uniform thickness at subgrade elevations required for accurate setting of pavers to finished grades indicated.
- F. Mix and place only that amount of mortar setting bed that can be covered with stone prior to initial set. Cut back, bevel edge, remove, and discard setting bed material that has reached initial set prior to placing stone.
- G. Arrange stone pattern(s) to provide consistent joint work throughout. Always work with a sufficient number of stone pieces to allow for selection of pieces to establish gradual transitions of differential coloration throughout the stone field. Select stone pieces to avoid abrupt light to dark edge transitions between individual pieces.
- H. Tamp and beat stone with a wooden block or rubber mallet to obtain full contact with setting bed and to bring finished surfaces within indicated tolerances. Set each unit in a single operation before initial set of mortar; do not return to areas already set and disturb stone for purposes of realigning finished surfaces or adjusting joints.
- I. Do necessary field cutting, as stone paving is set. Use power saws with diamond blades to cut stone. Cut lines straight and true, with edges eased slightly to prevent chipping.
- J. Installation Tolerances:
1. Variation from Level: For horizontal bands, horizontal grooves, and other conspicuous lines, do not exceed 1/16 inch in 10 feet, 1/8 inch in 20 feet, or 1/4 inch in 40' or more. Slope to drain as noted per Drawings.
 2. Variation of Linear Line: For positions shown in plan and related portions of walls and partitions, do not exceed 1/8 inch in 20 feet or 1/4 inch in 40 feet or more.
 3. Variation in Cross-Sectional Dimensions: For thickness of units from dimensions indicated, do not exceed plus or minus 1/8 inch.
 4. Variation in Joint Width: Do not vary joint thickness more than twenty-five percent of nominal joint width.
 5. Variation in Plane between Adjacent Stone Units (Lippage): Do not exceed 1/16-inch difference between planes of adjacent units.
- K. Provide joint widths as indicated in the Drawings or approved shop drawings.
- L. Grout joints as soon as possible after initial set of setting bed.

1. Force grout into joints, taking care not to smear grout on adjoining surfaces.
 2. Clean pavers as grouting progresses by dry brushing or rubbing with dry burlap to remove smears before tooling joints.
 3. Tool exposed joints slightly concave when thumbprint hard, using a jointer larger than joint thickness, unless otherwise indicated.
 4. If tooling squeezes grout from joints, remove excess grout and smears by dry brushing or rubbing with dry burlap and tool joints again to produce a uniform appearance.
- M. Cure grout by maintaining in a damp condition for seven days, unless otherwise recommended by grout or liquid-latex manufacturer.

3.3 BITUMINOUS SETTING-BED APPLICATIONS

- A. Placing of the Setting Bed:
1. Install the setting bed directly over a prepared concrete sub-base. Place two screed rails at desired width to serve as guides for the striking board. The screed rails should be carefully set to ensure proper setting bed depth and finished paver grade. If necessary, adjustments can be made under the screed rails with wood chucks or shims; typical setting bed depth is $\frac{3}{4}$ ". Place the bituminous material between the parallel screed rails. Position striking board perpendicularly over the screed rails and pull smooth. Repeat several times showering low porous spots with fresh bituminous material to yield a smooth, firm and even setting bed. As soon as this initial panel is completed advance the first bar to the next position in readiness for striking the next panel. Carefully fill any depressions that remain after removing the screed rails and wood chucks. The bed depth shall be adjusted to ensure the top surface of the placed pavers will be at the required finished grade.
- B. Jointing:
1. Asphalt Block: Pavers should be laid with joints hand tight to a maximum of 1/16" wide. The joints must be filled with a dry sand. This can be achieved by brushing the sand into the joints. Any surplus sand should be removed from the completed paving.
 2. Concrete Unit Pavers: Concrete Unit Pavers should be laid with a minimum joint width of 1/16" to a maximum 1/8". Care should always be taken to maintain this minimum joint spacing to minimize paver-to-paver contact. The joints should then be swept with dry sand. Any surplus sand should be removed from the completed paving.
 3. Application: for all on-grade applications, gauging of pavers is needed.
- C. For vehicular applications: The setting bed shall be screeded and rolled with a power roller while hot, to a nominal $\frac{3}{4}$ " depth. The thickness of the bed shall be adjusted so that when the pavers are placed, the top surface of the paver will be at the required finished grade. A neoprene tack coat should be used on a rolled bituminous setting bed. Install per manufacturer's specifications.

3.4 EPOXY SETTING-BED APPLICATIONS

- A. Apply per manufacturer's specifications

- B. Apply 4 beads of Paver Bond to back of paver

3.5 MORTAR SETTING BED APPLICATIONS

- A. Mortar Base: Install in conformance with manufacturer's directions for thick bed, bonded to underlying substrate and the following:
 - 1. Concrete subbase may be damp but no standing water should be present.
 - 2. Apply mortar-bed bond coat over surface of concrete subbase about 15 minutes before placing setting bed. Limit area of bond coat to avoid its drying out before placing setting bed. Do not exceed 1/16-inch thickness for bond coat.
 - 3. Apply mortar bed over bond coat immediately after applying bond coat. Spread and screed setting bed to uniform thickness at subgrade elevations required for accurate setting of pavers to finished grades indicated.
 - 4. Place reinforcing wire over concrete subbase, lapped at joints by at least one full mesh and supported so mesh becomes embedded in the middle of setting bed. Hold edges back from vertical surfaces approximately 1/2 inch (13 mm).
 - 5. Place mortar bed with reinforcing wire fully embedded in middle of setting bed. Spread and screed setting bed to uniform thickness at subgrade elevations required for accurate setting of pavers to finished grades indicated.
- B. Mix and place only that amount of mortar setting bed that can be covered with stone prior to initial set. Cut back, bevel edge, remove, and discard setting bed material that has reached initial set prior to placing stone.
- C. Arrange unit paver pattern(s) to provide consistent joint work throughout. Always work with a sufficient number of unit paver pieces to allow for selection of pieces to establish gradual transitions of differential coloration throughout the stone field. Select pieces to avoid abrupt light to dark edge transitions between individual pieces.
- D. Tamp and beat unit paver with a wooden block or rubber mallet to obtain full contact with setting bed and to bring finished surfaces within indicated tolerances. Set each unit in a single operation before initial set of mortar; do not return to areas already set and disturb pavers for purposes of realigning finished surfaces or adjusting joints.
- E. Do necessary field cutting, as unit paving is set. Use power saws with diamond blades to cut unit pavers. Cut lines straight and true, with edges eased slightly to prevent chipping.
- F. Provide joint widths as indicated in the Drawings or approved shop drawings.
- G. Grout joints as soon as possible after initial set of setting bed.
 - 1. Force grout into joints, taking care not to smear grout on adjoining surfaces.
 - 2. Clean pavers as grouting progresses by dry brushing or rubbing with dry burlap to remove smears before tooling joints.
 - 3. Tool exposed joints slightly concave when thumbprint hard, using a jointer larger than joint thickness, unless otherwise indicated.

4. If tooling squeezes grout from joints, remove excess grout and smears by dry brushing or rubbing with dry burlap and tool joints again to produce a uniform appearance.
- H. Cure grout by maintaining in a damp condition for seven days, unless otherwise recommended by grout or liquid-latex manufacturer.

3.6 ADJUSTING

- A. Remove and replace broken, chipped, stained, or otherwise damaged pavers and steps, defective joints, and pavers and steps that do not match approved samples and mockups. Damaged pavers and steps may be repaired if Professional approves methods and results.
- B. Replace in a manner that result in pavers and steps matching approved samples and mockups, complying with other requirements, and showing no evidence of replacement.
- C. In-Progress Cleaning: Clean pavers and steps as work progresses. Remove mortar fins and smears before tooling joints.

3.7 CLEANING, AND PROTECTION

- A. Clean stone paving no fewer than seven days after completion of pointing and sealing, using clean water and stiff-bristle fiber brushes. Do not use wire brushes, acid-type cleaning agents, cleaning agents containing caustic compounds or abrasives, or other materials or methods that could damage pavers and steps.
- B. Prohibit traffic from installed stone for a minimum of 72 hours.

3.8 WASTE MANAGEMENT

- A. Conform to waste management plan as specified in Section 01 74 19, Construction Waste Management and Disposal.

END OF SECTION

SECTION 323113

CHAIN LINK FENCES AND GATES

PART 1 - GENERAL

1.1 SUMMARY

- A. Stipulations
 - 1. The specifications sections "General Conditions to the Construction Contract", "Special Conditions" and "Division 01 - General Requirements" form a part of this Section by this reference thereto, and shall have the same force and effect as if printed herewith in full.
- B. General: Provide Chain Link Fences and Gates in accordance with requirements of the Contract Documents.
- C. Section Includes:
 - 1. Chain-link fences.
 - 2. Swing gates.
 - 3. Privacy slats.

1.2 ACTION SUBMITTALS

- A. Product Data: For each type of product.
- B. Shop Drawings: For each type of fence and gate assembly.
 - 1. Include plans, elevations, sections, details, and attachments to other work.
- C. Samples: For each exposed product and for each color and texture specified.

1.3 INFORMATIONAL SUBMITTALS

- A. Product certificates.
- B. Product test reports.
- C. Sample warranty.

1.4 WARRANTY

- A. Special Warranty: Installer agrees to repair or replace components of chain-link fences and gates that fail in materials or workmanship within specified warranty period.

1. Warranty Period: Five years from date of Substantial Completion.

PART 2 - PRODUCTS

2.1 MANUFACTURERS

- A. Long Fence
- B. Or approved equal

2.2 CHAIN-LINK FENCE FABRIC AND FRAMEWORK

- A. Products:
 1. Basis of Design: Long Fence Galvanized Chain Link Fence
 - a. Mesh Size: 2 inches (50 mm)
 - b. Posts and Rails: ASTM F1043 for framework, including rails, braces, and line; terminal; and corner posts. Provide members with minimum dimensions and wall thickness according to ASTM F1043 or ASTM F1083 based on the following:
 - c. Fence Height: 72 inches (1830 mm)

2.3 SWING GATES

- A. General: ASTM F900 for gate posts and single.
 1. Gate Leaf Width: ~~36 inches (914 mm)~~ **See Drawings**
- B. Pipe and Tubing:
 1. Zinc-Coated Steel: ASTM F1043 and ASTM F1083; protective coating and finish to match fence framework
- C. Frame Corner Construction: Assembled with corner fittings.
- D. Hardware:
 1. Hinges: 180-degree outward swing.
 2. Latch: Permitting operation from both sides of gate.

2.4 FITTINGS

- A. Provide fittings according to ASTM F626.
- B. Finish:
 1. Metallic Coating for Pressed Steel or Cast Iron: Not less than 1.2 oz./sq. ft. (366 g/sq. m) of zinc.

2.5 PRIVACY SLATS

- A. Fiber-Glass-Reinforced Plastic Slats: UV-light-stabilized fiber-glass-reinforced plastic, not less than 0.06 inch (1.5 mm) thick, sized to fit mesh specified for direction indicated, with vandal-resistant fasteners and lock strips.
- B. Color: Match PT-03 CMU

2.6 GROUT AND ANCHORING CEMENT

- A. Nonshrink, Nonmetallic Grout: Factory-packaged, nonstaining, noncorrosive, nongaseous grout complying with ASTM C1107/C1107M. Provide grout, recommended in writing by manufacturer, for exterior applications.
- B. Anchoring Cement: Factory-packaged, nonshrink, nonstaining, hydraulic-controlled expansion cement formulation for mixing with water at Project site to create pourable anchoring, patching, and grouting compound. Provide formulation that is resistant to erosion from water exposure without needing protection by a sealer or waterproof coating, and that is recommended in writing by manufacturer for exterior applications.

PART 3 - EXECUTION

3.1 EXAMINATION

- A. Do not begin installation before final grading is completed unless otherwise permitted by Architect.

3.2 PREPARATION

- A. Stake locations of fence lines, gates, and terminal posts. Do not exceed intervals of 500 feet (152 m) or line of sight between stakes. Indicate locations of utilities, lawn sprinkler system, underground structures, benchmarks, and property monuments.

3.3 CHAIN-LINK FENCE INSTALLATION

- A. Install chain-link fencing according to ASTM F567 and more stringent requirements specified.
- B. Post Excavation: Drill or hand-excavate holes for posts to diameters and spacings indicated, in firm, undisturbed soil.
- C. Post Setting: Set posts in concrete at indicated spacing into firm, undisturbed soil.

1. Verify that posts are set plumb, aligned, and at correct height and spacing, and hold in position during setting with concrete or mechanical devices.
 2. Concrete Fill: Place concrete around posts to dimensions indicated and vibrate or tamp for consolidation. Protect aboveground portion of posts from concrete splatter.
 - a. Concealed Concrete: Place top of concrete 2 inches (50 mm) below grade to allow covering with surface material.
- D. Terminal Posts: Install terminal end, corner, and gate posts according to ASTM F567 and terminal pull posts at changes in horizontal or vertical alignment of 15 degrees or more. For runs exceeding 500 feet (152 m), space pull posts an equal distance between corner or end posts.
- E. Line Posts: Space line posts uniformly at 10 feet o.c.
- F. Chain-Link Fabric: Apply fabric to outside of enclosing framework. Leave 2-inch (50-mm) bottom clearance between finish grade or surface and bottom selvage unless otherwise indicated. Pull fabric taut and tie to posts, rails, and tension wires. Anchor to framework so fabric remains under tension after pulling force is released.
- G. Privacy Slats: Install slats in direction indicated, securely locked in place.
 1. Diagonally

3.4 ADJUSTING

- A. Gates: Adjust gates to operate smoothly, easily, and quietly, free of binding, warp, excessive deflection, distortion, nonalignment, misplacement, disruption, or malfunction, throughout entire operational range. Confirm that latches and locks engage accurately and securely without forcing or binding.
- B. Lubricate hardware and other moving parts.

END OF SECTION

DATE: June 30, 2023

DEPARTMENT OF GENERAL SERVICES
BUREAU OF CAPITAL PROJECT DESIGN MANAGEMENT
1800 HERR STREETS
HARRISBURG, PENNSYLVANIA

ADDENDUM NO. 29

on

PROJECT NO. DGS C-0211-0005 PHASE 005
PROJECT TITLE - PA State Police Academy - Core Bldgs, BESO & Sitework
PROFESSIONAL:
SOM
7 World Trade Center
New York, NY, 10007

If you submitted a bid prior to this Addendum being issued, your bid has been discarded and you must re-submit your bid(s) prior to the bid opening date and time.

GENERAL CHANGES – ALL CONTRACTS

Item 1 - Please note the following:

Final questions must be submitted via e-Builder no later than 5:00 PM ET on Tuesday, July 18.

Final Addendum will be issued via e-Builder no later than Tuesday, July 25th.

Bids are due by Tuesday, August 1, no later than 2:00 PM. This is a very tight bidding schedule so please manage your time effectively.

Item 2 - Addendums for this bid begin with Addendum 24. Please note that Addendums 1-23 were issued in the course of the previous bid process and can be disregarded for the purposes of this bid. Items issued in addendums from the previous bid process have been incorporated into the current, re-issued bid documents.

Item 3 - Additional individuals from any bidder wishing to gain access to the bid documents must register through eMarketplace and create an account to access e-Builder. Access cannot be granted in any other fashion.

Item 4 - The optional pre-bid conference was held at the Pennsylvania State Police Academy on Friday, June 16 as notified in Addendum 26. Issued with the addendum are materials presented by SOM at that meeting for reference only. Concept phasing diagrams are shared for reference only, final phasing to be coordinated by contractors under means & methods of construction.

Item 5 - In response to questions submitted, please note the following:

.1 CONTRACT

- Question 72: CLT: What aspect of the CLT is delegated design? The documents indicate size, species and loading. Please advise.

- Response: The entire CLT construction should be delegated design to satisfy the design requirements in Mass Timber notes on GEN-S-016 and APA PRG 320. The CLT construction includes CLT panel and connections. The proposal of using alternative species should meet the required design strength and APA PRG 320. However, Douglas Fir should be used at the bottom exposed layer for architectural aesthetics, refer to Mass Timber notes on GEN-S-016.
- Question 73: CLT: Spec section 061719 - 2.1 - B indicates a certification showing timber is to be sustainably sourced and harvested. What are the sustainability requirements?
- Response: Acceptable industry standard certifications include the following: Forest Stewardship Council (FSC), Sustainable Forestry Initiative (SFI), American Tree Farm System (ATFS), and Canadian Standards Association (CSA).
- Question 74: CLT: Spec section 061719 - 2.1 - G indicates FRT treatment is required. It is our understanding that CLT cannot be fabricated with FRT lumber. Please advise.
- Response: Refer to revised specification 061719 as revised in Addendum 29. FRT treatment has been removed.
- Question 75: Glulam: Spec section 061800 - 2.1 - B indicates a certification showing timber is to be sustainably sourced and harvested. What are the sustainability requirements?
- Response: Acceptable industry standard certifications include the following: Forest Stewardship Council (FSC), Sustainable Forestry Initiative (SFI), American Tree Farm System (ATFS), and Canadian Standards Association (CSA).
- Question 83: Addendum #27 Question 26: The answer to this question is that the .1 and .2 contractors need to coordinate electricity and fuel requirements for temporary heat. That can't be done until after contracts are awarded so the .1 contractor doesn't know what to include in bid for fuel and electric for temporary heat. Please advise.
- Response: Bidders are to provide bids for estimation of temporary heat provisions during construction. Further adjustment requiring coordination with other contractors will be coordinated after award.
- Question 84: Owner Parking: What are the parking requirements, per phase, that need to be maintained for the Owner?
- Response: 125 spaces to be provided on site, remaining owner spaces will be provided off-site at adjacent facility, coordinated by owner.
- Question 85: Addendum 27 Questions 28 and 29: The answer provided on these is to coordinate with Package 2.1 contractor. This doesn't provide any direction for bidding purposes. We need to know the duration provided for these two buildings in order to insert into our schedule. Please advise.
- Response: Durations for not-in-contract work will be coordinated after award.
- Question 86: Addendum 27 Question 35 TE-01: Response to Question 35 regarding TE-01 only tells us that the fence is 6' tall. Please provide details. What is the gate width? Spec 323113 says 3' but that doesn't make sense for a trash enclosure. Are there bollards? Are we to scale the size of these enclosures?
- Response: Please see new detail 3/STE-L-901 for additional information on gate width, bollards, and general sizing for trash enclosures included in Addendum 29. Specification section 323113 has been revised.
- Question 89: Addendum 27 Question 46: Addendum 27 Response #46 calls for us to provide a lump sum to underpin/support the existing building. The EOR needs to provide the extent of underpinning required in

order to price. We don't have locations, dimensions, depths, quantities, or existing drawings to provide a price for this work.

- Response: Refer to Question 3 response as issued in Addendum 24. The evaluation of the of the existing building to remain adjacent to the soil nail wall is part of the soil nail wall design. Contractor bids should include the cost to retain a Professional Engineer licensed in Pennsylvania to design all aspects of the soil nail wall including any necessary support of the adjacent existing building to remain during construction that are deemed necessary as part of the soil nail wall design to allow construction of the soil nail wall without impacting the existing building. The contractor's engineer must determine the type of support, locations, dimensions, depths and quantities of any support required to the existing building. No drawings are available for the existing building to remain; any exploration of the building foundations needed for the design should be included in the bid cost.
- Question 92: Excavation: Please confirm that the .2, .3, and .4 contractors have all of their own excavation and backfill within 5' of the buildings and within the building footprints.
- Response: The .1 General Contractor is responsible for all excavation & backfill. The .1 General Contractor is responsible for installation for incoming service duct bank and all utility work 5' outside the building footprints.
- Question 93: Geothermal Excavation: Please confirm the .2 contractor is responsible for excavation and backfill for geothermal work since this is delegated design and is not currently shown on the documents.
- Response: The .1 General Contractor is responsible for all excavation & backfill. Work will need to be coordinated with .2 contractor during construction. Bidders are to provide bids for estimation of excavation during construction.
- Question 94: Generator Conduit: On drawing STE-C-701 the emergency generator conduit to the Marquee building runs through the existing building that needs to remain during the Marquee construction. Please advise.
- Response: Refer to revised drawing STE-C-701 as issued in Addendum 29 for the emergency generator conduit routing around existing academy.
- Question 95: Parking for Marquee: Please confirm what parking is needed to be turned over when the Marquee building is occupied.
- Response: 125 spaces to be provided on site through duration of project, remaining owner spaces will be provided off-site at adjacent facility, coordinated by owner.
- Question 96: Wage Rates: Please confirm the wage rates provided are good for the entire duration of the project. If not, please provide wage rates for entire duration.
- Response: Confirmed, bidders are only responsible for wage rates at time of issuance.
- Question 97: Excess Soils: Please confirm all excess soils can be placed on the site and that they don't need to be hauled away.
- Response: The design intent is that no material will be exported from the site. Please note that 20,000 CY of export material from this contract must be coordinated with adjoining contract area as shown on plans. Any remaining material could either be further coordinated with adjoining contract or spoiled on undeveloped areas on the site within the limit of disturbance.

- Question 98: Site Electric: Please confirm that the prime electrical contractor will have excavation and backfill and duct banks for the site electric. Profiles, amount of pipes, and pipes sizes are not provided for the .1 contractor to price this work.
- Response: The .1 General Contractor is responsible for excavation, backfill, duct banks, concrete encasement, manholes and any associated site work. The .4 Electrical contractor is responsible for all raceways, conduits, cabling initiated at the switchgear.
- Question 99: Masonry: Drawings ITV-A-111 and ITV-A-602 shows a masonry partition along column line M10 that does not have a label. Please confirm N1 is the correct masonry partition type.
- Response: Response will be provided in an upcoming addendum.
- Question 100: Masonry: The exterior masonry walls in the Auditorium of the Marquee Building are not completely labeled. Only the exterior finish is labeled as CMU-01 however, the backup CMU does not have a label. Please confirm CMU-08A is correct. See MAQ-A-568, 1/MAQ-A-515, 3/MAQ-A-565, MAQ-A-516, GEN-A-520 for reference.
- Response: Backup walls to be CMU-08 per Wall Type buildup described on GEN-A-500 - EXTERIOR WALL TYPES. For Wall Type, see MAQ-A-500 - WALL TYPE KEY ELEVATION.
- Question 101: Phasing Plan: A phasing plan was shared at the pre-bid meeting but was not issued in Addendum #28. Please provide.
- Response: Presentation is issued in Addendum 29 for reference only, final phasing to be coordinated by contractor under means & methods of construction.
- Question 102: STE-L-900: Please confirm where detail 8/STE-L-900 applied. I don't see where PV 4.0 is set up against the building and the Materials Schedule doesn't show PV 4.0 getting a concrete setting bed below it. PAV-03 is shown up against the building and does have a concrete setting bed underneath.
- Response: Detail occurs at paving that leads to main/central entry to Marquee Building. See revised detail in Addendum 29 drawings which indicates PAV-03 in lieu of PV 4.0.
- Question 103: Splash Pad: 4/STE-L-901 shows details for a splash pad and there a few questions regarding these details. A) Where are these splash pads shown in plan to quantify them? B) These details reference a material ST which doesn't show up in the material schedule to know that ST is. C) Please provide details for the concrete trench. D) Details points to a 4" wide concrete trench under ST but the concrete is shown to go up to grade. Please advise.
- Response: A) Refer to Sheet STE-L-104_D for splash pad location. B) ST revised to LST-01 C) Please see revised detail 4/STE-L-901 included in Addendum 29. D) Please see revised detail 4/STE-L-901 included in Addendum 29.
- Question 104: Retaining Walls: STE-C-454 has a detail for retaining wall. 5/STE-L-901 also has detail for site retaining wall. Please confirm which details apply where.
- Response: Detail 5/STE-L-901 only applies to the site wall explicitly called out in the Landscape drawings on Sheet STE-L-104. Refer to Civil details for all other site retaining walls.
- Question 105: Drain Covers: Spec 321400 2.2 and 2.3 call for drain covers in the unit pavers and mention to see material schedule and drawings for material type, size, and finish. Please confirm where this information is shown on the drawings.
- Response: 321400, 2.2-2.3 are not applicable and have been removed from the Specification.

- Question 106: Bollards: STE-C-451 has a bollard detail and STE-L-901 has a different bollard detail. Please confirm which detail goes where.
- Response: Bollards shown in details 2/STE-L-901 and included in Materials Schedule apply only to bollards explicitly called out in the Landscape drawings on Sheets STE-L-104 and STE-L-104_D. All other bollards, including at trash enclosure should follow the Civil detail.
- Question 107: Abatement: Spec 020800 notes that all layers of flooring needs to be removed at areas where ACM is identified. Please confirms types of flooring and layers where ACM is identified in order to provide a price.
- Response: Response will be provided in an upcoming addendum.
- Question 108: Abatement: Abatement spec 020800 and H series drawings note that Abatement contractor is responsible for all ACM removal whether it has been identified or not. This is not quantifiable or reasonable for a hard bid situation to know what cost to include. Please provide specific direction/quantities or an allowance for this work.
- Response: Response will be provided in an upcoming addendum.
- Question 109: Builder's Risk: We are being told by our builder's risk broker that the Marquee building could be classified as a mass timber project and will require special insurance. Should this building be classified as mass timber?
- Response: Response will be provided in an upcoming addendum.
- Question 110: Existing Kennel Buildings: Spec section 013110 notes that the existing kennel building can be demolished at any time for the construction of the BESO building. At the pre-bid, it was mentioned that the BESO building needed to be in phase 2. Please confirm.
- Response: Response will be provided in an upcoming addendum.
- Question 111: Geothermal Wells: Do all of the geothermal well fields need to be installed and activated for the turnover of the Marquee building? If so, this creates a phasing issue with the existing buildings that need to remain during the construction of the Marquee building such as, stables, garage building A, garage building b, and existing headquarters.
- Response: Response will be provided in an upcoming addendum.
- Question 112: Temporary Access Roads: Drawing STE-C-811 shows a conceptual access road the goes through a drainage basin and yard inlet. Please advise.
- Response: Response will be provided in an upcoming addendum.
- Question 113: Food Service: Please confirm the Hot Line Serving M-1205A casework and countertops are part of the Food Service Equipment package. If not, please provide section details and labels for the casework and countertops. Reference MAQ-QF-111.
- Response: Confirmed, All equipment and casework in M-1205A, Hot Line Serving, are part of the Food Service Equipment package.
- Question 114: Servery: Please confirm the cabinets of the Cold Line Servery M-1204 and Beverage Station M-1202 part of the Food Service Equipment package. Reference MAQ-QF-113.
- Response: Confirmed, All equipment and casework in M-1204, Cold Line Serving, are part of the Food Service Equipment package.

- Question 115: FTU Wall: FTU Site wall detailed on 5/GEN-A-521 indicates a fully grouted CMU backup wall, however, the backup CMU wall is labeled as CMU-01A, which is a 4" split face CMU. Please confirm R2 or N12 is the correct CMU type.
- Response: Site wall to be CMU-02 backup, faced with CMU-01. See 5/, 11/GEN-A-521 as issued in Addendum #29. Please note that CMU-01A is an 8x8x24 block per 042000.2.3.B
- Question 116: Ceiling Trim: Specification Section 092116 Gypsum Board Assemblies 2.7 Trim Accessories B. Metal Specialty Accessories 1. (call out the following) b. Channel Wall Reveal, c. Rounded Outside Corner d. Base Reveal e. W-Reveal f. Corner Trim g. Column Collar h. Partition End Caps. I do not see any of these trims shown on the drawings. Are any of these trims to be used in the project?
- Response: Response will be provided in an upcoming addendum.
- Question 117: Abuse vs impact: Specification Section 092166 Gypsum Board Assemblies 2.4 Gypsum Board Materials Gypsum Board 1. Provide Abuse Resistant Panels for the first 8 ft. of all gypsum board partitions, unless otherwise indicated. 3.4 C. Panel Materials 1. General Install Impact Resistant panels for the first 8ft. of all gypsum board partitions. Please clarify either Abuse or Impact board. There is a significant difference in cost.
- Response: Response will be provided in an upcoming addendum.
- Question 118: Masonry: Drawing note B1 in the BSO-A drawings reads "SEE STRUCTURAL" regarding load bearing CMU, however, there is no information regarding load bearing CMU in the BSO-S drawings. Please advise.
- Response: Refer to BSO-S-101.

2 CONTRACT

- Question 2: HVAC -1: Specification 230700 3.1 K. Ductwork Table - Lists Insulation type "D" for Exposed insulation in mechanical rooms or areas subject to damage. There is no specification for Type D insulation. Provide if applicable.
- Response: Refer to revised specification section 230700, as issued in Addendum 29.
- Question 3: HVAC-2: Specification 230700 3.1 L. Pipe Table - Lists Insulation type "4" for many pipes. There is no specification for Type 4 insulation. Provide if applicable.
- Response: Refer to revised specification section 230700, as issued in Addendum 29.
- Question 4: HVAC-3: Drawing BSO-M-402 B-CRAC-1 has no associated condensing unit associated. Provide Unit schedule with performance and electrical characteristics and location.
- Response: Refer to BSO-M-402 CRAC Unit Schedule, Note 2 states that B-CRAC-1 is a self contained unit. No external CU needed. Heat rejected to return area plenum.
- Question 5: HVAC-4: Drawing BSO-M-401 Split System Condensing Units B-CU-1 has a scheduled capacity of 600MBH while corresponding B-AHU-1 has a scheduled total DX capacity of 646.3MBH. Confirm this is correct.
- Response: Scheduled condensing unit confirmed. B-AHU-1 has a coil capacity of 637 MBH and B-CU-1 has a nominal capacity of 600 MBH.
- Question 6: HVAC-5: Drawing BSO-M-401 Split System Condensing Units B-CU-7 lists related fan as B-FCU-3. Confirm this should be B-FCU-6.
- Response: Confirmed, this should be FCU-6. Refer to revised drawing BSO-M-401 as issued in Addendum 29.

- Question 7: HVAC-6: Specification 230933 1.5 3. c. & 1.5 4. e. states control conduits provided by electrical contractor. While 230933 3.1 A. 4. States all control conduits shall be provided by range ventilation contractor.
- Response: Spec 230933 3.1 A.4 applies to indoor firing range (FTU) building. For that building range ventilation contractor is to provide controls conduit. For all other buildings, Spec 230933 1.5.3.c & 1.5.4.e applies and controls conduit to be provided by electrical contractor.
- Question 8: HVAC-6: Specification 230933 1.5 3. c. & 1.5 4. e. states control conduits provided by electrical contractor. While 230933 3.1 A. 4. States all control conduits shall be provided by range ventilation contractor. Confirm who is providing / installing control conduit.
- Response: Spec 230933 3.1 A.4 applies to indoor firing range (FTU) building. For that building range ventilation contractor is to provide controls conduit. For all other buildings, Spec 230933 1.5.3.c & 1.5.4.e applies and controls conduit to be provided by electrical contractor.
- Question 9: HVAC-7: M-DEF-1 & M-DEF-2 dryer exhaust fans: Provide control sequence for M-DEF-1 & M-DEF-2 dryer exhaust fans.
- Response: Refer to revised MAQ-M-807 as issued in Addendum 29, including sequence of operations for M-DEF-1 & M-DEF-2 dryer exhaust fans.
- Question 10: HVAC-8: Specification 015000-3 1.4 k. states the Lead Contractor is to provide appropriate ventilation, dehumidification, humidification and cooling to meet building finish requirements. Specification 230000 3.14 A. instructs the Mechanical Contractor to do the same. Provide clarification of this duplication in scope.
- Response: Responsibility for General Contractor. Refer to revised specification section 230000 as issued in Addendum 29.
- Question 11: HVAC-9: Control Sequence: Provide a Control Sequence of Operation for G-DHU-1 serving Tank Training.
- Response: SOO on GYM-M-800 applies to G-DHU-1. SOO title to be revised to include G-DHU-1 in name. Refer to revised GYM-M-800 as issued in Addendum 29.
- Question 12: HVAC-10: GYM -M-122 depicts (2) 14" branch ducts serving Cardio Area (G-151); the branch ducts never reduce in size for the entire run of SG-1 outlets. Confirm this is the intent.
- Response: Confirmed, intent is to keep at 14".
- Question 13: HVAC-11: Mechanical Equipment Anchorage : General Detail for Mechanical Equipment Anchorage (all buildings) states that if anchorage embedment depth is deeper than ½" contractor shall hire a California registered structural engineer to perform analysis and calculations as required by the landlord. Confirm if this is applicable to the project.
- Response: Reference to California registered structural engineer is removed. Refer to revised MAQ-M-701, GYM-M-701 and FTU-M-701 drawings as issued in Addendum 29.
- Question 14: HVAC-12: Drawings MAQ-M-700 & BSO-M-701 depict a detail for: Slot with Integral Volume Damper. Note A. states: All slot diffusers located in ceilings are to be provided and installed by the ceiling contractor (S.A.D.). Confirm this is the intent.
- Response: Reference to be installed by ceiling contractor is removed. Refer to revised drawings MAQ-M-700 and BSO-M-701 as issued in Addendum 29.

- Question 15: HVAC-13 Drawing BSO-M-402 Diffuser, Register and Grille Schedule. CD-1, provide round neck size.
- Response: Refer to revised BSO-M-402 as issued in Addendum 29, indicating round neck size.
- Question 16: HVAC-14 Drawing BSO-M-121 BESO Lounge B-222 shows (4) CD-1 Diffusers at 300 CFM/Ea. Scheduled airflow for CD-1 is 200 CFM Max. Confirm this is correct.
- Response: Diffusers serving BESO Lounge B-222 should be CD-4. Airflows confirmed correct. Refer to revised BSO-M-121 as issued in Addendum 29 indicating correct diffuser type.
- Question 17: HVAC-15 Drawing BSO-M-111: Drawing BSO-M-111 K9 Classroom B-129 depicts (1) CD-1/185 CFM. What is the other ceiling diffuser designation and air flow in this room.
- Response: CD-1/185 cfm is typical for both diffusers in B-129 K9 Classroom. Refer to revised BSO-M-111 as issued in Addendum 29.
- Question 18: HVAC-16 Specification 230700 3.1, L.Breeching Insulation Table – Breeching, Generator Exhaust Lists only Type 3 Insulation. Provide Type 3 Insulation Specification. ALSO, Heating and Chilled Water Storage and Air Separation Tanks and Heat Exchangers (Steam & Hydronic) lists Type 5 Insulation. Provide Type 5 Insulation if applicable.
- Response: Refer to revised spec section 230700 as issued in Addendum 29, clarifying types 3 and 5.
- Question 19: HVAC-17 Specification Section 230517: References are made referring to Specification Section 230517 “Sleeves and Seals for HVAC Piping”. Provide 230517 Section if applicable.
- Response: Response will be provided in an upcoming addendum.
- Question 20: HVAC-18 Control Sequence for Unit G-DHU-1: Provide a control sequence for Unit G-DHU-1 serving Training Tank G-130.
- Response: Reference response to question 9 and revised documents as issued in Addendum 29.
- Question 21: BESO Building: Please clarify the emergency generator BAS integration and controls scope.
- Response: Refer to revised control drawings as issued in Addendum 29 clarifying generator monitoring.
- Question 22: Marquee Building: Please clarify the emergency Generator BAS integration and controls scope.
- Response: Refer to revised control drawings as issued in Addendum 29 clarifying generator monitoring.
- Question 23: PICVs: Regarding specification section 230900, 2.14, F, 4: Please clarify locations and BAS monitoring for PICVs.
- Response: Refer to control drawings for BAS monitoring requirements and plan drawings for equipment locations
- Question 24: ePICVs: Regarding specification section 230900, 2.14, G: Please clarify locations and BAS monitoring for ePICVs.
- Response: Refer to control drawings for BAS monitoring requirements and plan drawings for equipment locations
- Question 25: Construction Schedule: Please provide building construction schedules.
- Response: Building construction schedule is being coordinated by .1 General Contractor and will be provided after award. Refer to spec section 013110 for critical milestones.
- Question 26: Firearms Training Unit: Does the firing range control system integrate into the BAS?
- Response: Yes. Refer to controls drawings.
- Question 27: 3rd Party Integration

- Response: Spec section referenced provides direction for controls contractor to intergrate points as shown on controls drawings regardless of protocol.
- Question 28: Electric Meters: Specification 230900, 2.3, D, 9, d refers to electrical meter reporting but electrical meters are not shown on the electrical drawings. Please verify meter location(s).
- Response: Electrical meters are on one line diagrams, refer to electrical drawings.
- Question 29: Gas Meters: Specification 230900, 2.3, D, 9, e refers to gas meter reporting but gas meters are not shown on the plumbing drawings. Please verify meter location(s).
- Response: Plumbing drawings show gas meters, refer to plumbing drawings.
- Question 30: Airflow Station Alternates: Regarding specification 230900, 2.14, I, 3: Are Accutrol duct mounted airflow stations an acceptable alternate?
- Response: Provide equipment as listed in specifications, alternates will not be accepted prior to award.
- Question 31: Ethernet Cabling Responsibilities: Please clarify who is responsible for ethernet cabling from the data closets to IP based BAS control panels and equipment with BAS IP integration.
- Response: Response will be provided in an upcoming addendum.
- Question 32: Marquee Building: Please clarify if there is any BAS integration or monitoring for the trench heaters.
- Response: BAS integration is not required.

SPECIFICATION CHANGES – ALL CONTRACTS

Item 1 - Please refer to the attached documents for updated specifications as described in responses to questions and listed below.

NUMBER / NAME / ACTION

061719 / Cross Laminated Timber / Revised

230000 / Heating, Ventilating and Air Conditioning (HVAC) Basic Requirements / Revised

230700 / HVAC Insulation / Revised

321400 / UNIT PAVING / Revised

323113 / CHAIN LINK FENCES & GATES / Revised

DRAWING CHANGES – ALL CONTRACTS

Item 1 - Please refer to the attached documents for updated drawings as described in responses to questions and listed below.

NUMBER / NAME / ACTION

STE-L-110 / MATERIALS SCHEDULE / Revised (schedule revised)

STE-L-900 / HARDSCAPE DETAILS / Revised (paver detail clarified)

STE-L-901 / HARDSCAPE DETAILS / Revised (paver detail clarified)

GEN-A-521 / TYPICAL CMU DETAILS / Revised (Detail annotation revised)

MAQ-M-700 / AIRSIDE DETAILS / Revised (note revised)

MAQ-M-701 / AIRSIDE DETAILS / Revised (note revised)

MAQ-M-807 / CONTROLS - MECHANICAL / Revised (Controls clarified)

GYM-M-700 / AIRSIDE DETAILS / Revised (note revised)
GYM-M-701 / AIRSIDE DETAILS / Revised (note revised)
GYM-M-801 / CONTROLS – MECHANICAL / Revised (Controls clarified)
FTU-M-700 / AIRSIDE DETAILS / Revised (note revised)
FTU-M-701 / AIRSIDE DETAILS / Revised (note revised)
FTU-M-802 / CONTROLS - MECHANICAL / Revised (Controls clarified)
BSO-M-111 / FLOOR PART PLAN B - LEVEL 1 -MECHANICAL / Revised (airflows clarified)
BSO-M-121 / FLOOR PART PLAN B - LEVEL 2 -MECHANICAL / Revised (airflows clarified)
BSO-M-401 / SCHEDULES- MECHANICAL / Revised (schedule clarified)
BSO-M-402 / SCHEDULES- MECHANICAL / Revised (schedule clarified)
BSO-M-800 / CONTROLS - MECHANICAL / Revised (controls clarified)
OTV-M-800 / CONTROLS – MECHANICAL / Revised (controls clarified)

GENERAL SHEET NOTES

- PROVIDE ACOUSTIC LINING ON FIRST 5' OF DUCT DOWNSTREAM OF ANY VAV BOXES WITH SIZES OF 9" OR LESS.
- PROVIDE ACOUSTIC LINING ON FIRST 10' OF DUCT DOWNSTREAM OF ANY VAV BOXES WITH SIZES OF 9" OR MORE.
- PROVIDE ACOUSTIC LINING ON FIRST 15' OF DUCT DOWNSTREAM OF ANY FPB.
- PROVIDE ACOUSTIC LINING ON FIRST 20' OF SUPPLY AND EXHAUST/RETURN DUCT DOWNSTREAM OF ANY AHU.
- PROVIDE ACOUSTIC LINING ON FIRST 10' OF DUCT UPSTREAM AND DOWNSTREAM OF ANY FAN.

SHEET KEYNOTES

- PROVIDE EXHAUST LOUVER WITH 19 SQFT OF FREE AREA
- PROVIDE INTAKE LOUVER WITH 1.25 SQFT OF FREE AREA
- PROVIDE CONDENSATE DRAIN. DRAIN SIZE TO MATCH EQUIPMENT CONNECTION SIZE. SEE PLUMBING DRAWINGS FOR CONTINUATION.
- BALANCE TO 250 CFM
- PROVIDE EXHAUST LOUVER WITH 0.7 SQFT OF FREE AREA
- PROVIDE EXHAUST LOUVER WITH 0.8 SQFT OF FREE AREA
- PROVIDE 10" VENT CAP.
- PROVIDE SUPPLY GRILLES 7' FROM FF. SUPPLY AIR TO BE DIRECTED TOWARDS FLOOR.
- PROVIDE CONDENSATE DRAIN. DRAIN SIZE TO MATCH EQUIPMENT CONNECTION SIZE. PROVIDE DOMESTIC COLD WATER SUPPLY CONNECTION. SEE PLUMBING DRAWINGS FOR CONTINUATION.
- PROVIDE FIRE/SMOKE DAMPER IN SECOND FLOOR SLAB.
- PROVIDE 4" DRYER VENT CAP AT 16' ABOVE GRADE.
- BMS PANEL LOCATION

TACTICAL TRAINING DESIGN

Tactical Design North

231 E. Buffalo St #502, Milwaukee, WI 53202

LOCAL ARCHITECT

Jacobs Wyper Architects

1232 Chancellor St, Philadelphia, PA 19107

STRUCTURAL ENGINEER

Skidmore, Owings & Merrill LLP

250 Greenwich St, New York, NY 10007

ELECTRICAL, PLUMBING, FIRE PROTECTION, FIRE ALARM ENGINEER

A & J Consulting Engineering Services, P.C.

164 Brighton Rd, Clifton, NJ 07012

MECHANICAL AVIT ENGINEER

Interface Engineering, Inc.

2000 M Street NW, Suite 270, Washington, DC 20036

ACOUSTICAL ENGINEER

Cerami

1001 Ave of the Americas, 4th Floor, New York, NY 10018

CODE CONSULTING

CCI

215 W 40th St, 10th Floor, New York, NY 10018

CIVIL ENGINEER

Langan

1818 Market St #3300, Philadelphia, PA 19103

VERTICAL TRANSPORT

Michael Blades & Associates Ltd.

5409 Rapihan Ct, Lothian, MD 20711

SIGNAGE CONSULTANT

Patricia Hord Graphik Design

119 S. St. Asaph St, Alexandria, VA 22314

LANDSCAPE

Lee and Associates, Inc.

638 I Street NW, Washington, DC 20001

LIGHTING

MCLA

1000 Patomac St NW, Suite 121, Washington, DC 20007

FOOD SERVICE

Hopkins Foodservice Specialists, Inc.

7906 MacArthur Blvd, Suite 100, Cabin John, MD 20818

COST ESTIMATING

AECOM

1700 Market St, Suite 1600, Philadelphia, PA 19103

KEYPLAN

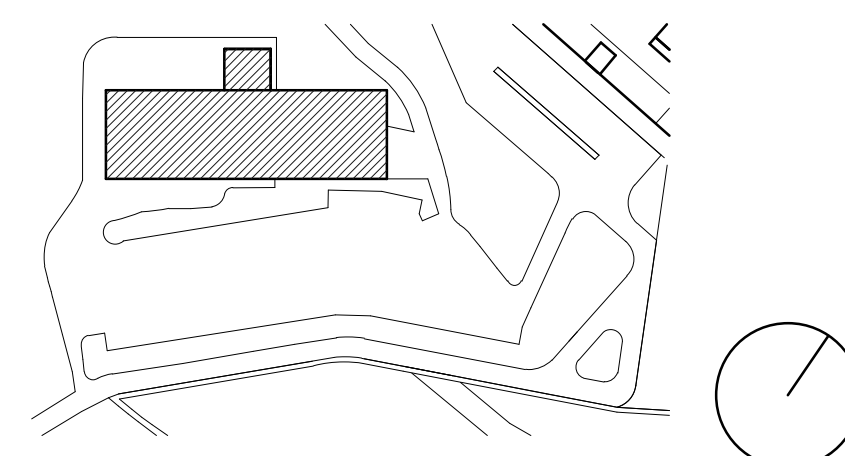

NO.	DATE	DESCRIPTION	NO.	DATE	DESCRIPTION
3	09 JUN 2023	ADDENDUM 26			
2	19 MAY 2023	ISSUED FOR BID			
1	28 JAN 2022	ISSUED TO L&I			

RECORD REVISIONS

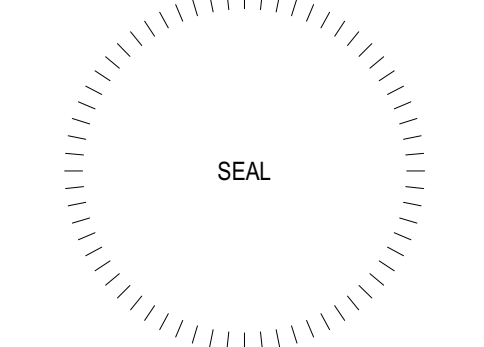

SIGNATURE DATE

ARCHITECT

SOM
Skidmore, Owings & Merrill LLP
250 Greenwich St, New York, 10007

COMMONWEALTH OF PENNSYLVANIA

DEPARTMENT OF GENERAL SERVICES

HARRISBURG, PENNSYLVANIA

D.G.S. PROJECT No.

C-0211-0005 PHASE 5

Pennsylvania State Police Academy

Core Buildings, BESO & Sitework

PENNSYLVANIA STATE POLICE

HERSHEY, DAUPHIN COUNTY, PA

SHEET No. **BSO-M-111**

CONTRACTOR SHALL FIELD VERIFY ALL DIMENSIONS. VARIANCE FROM CONTRACT DOCUMENTS NOT PERMITTED WITHOUT PROFESSIONAL & BUREAU OF CONSTRUCTION APPROVAL.

DRAWN BY: Author CHECKED BY: Checker DATE: SCALE: AS NOTED

FLOOR PART PLAN B - LEVEL 1 -MECHANICAL

1/8" = 1'-0"

1/8" = 1'-0"

1/8" = 1'-0"

1/8" = 1'-0"

1/8" = 1'-0"

1/8" = 1'-0"

1/8" = 1'-0"

1/8" = 1'-0"

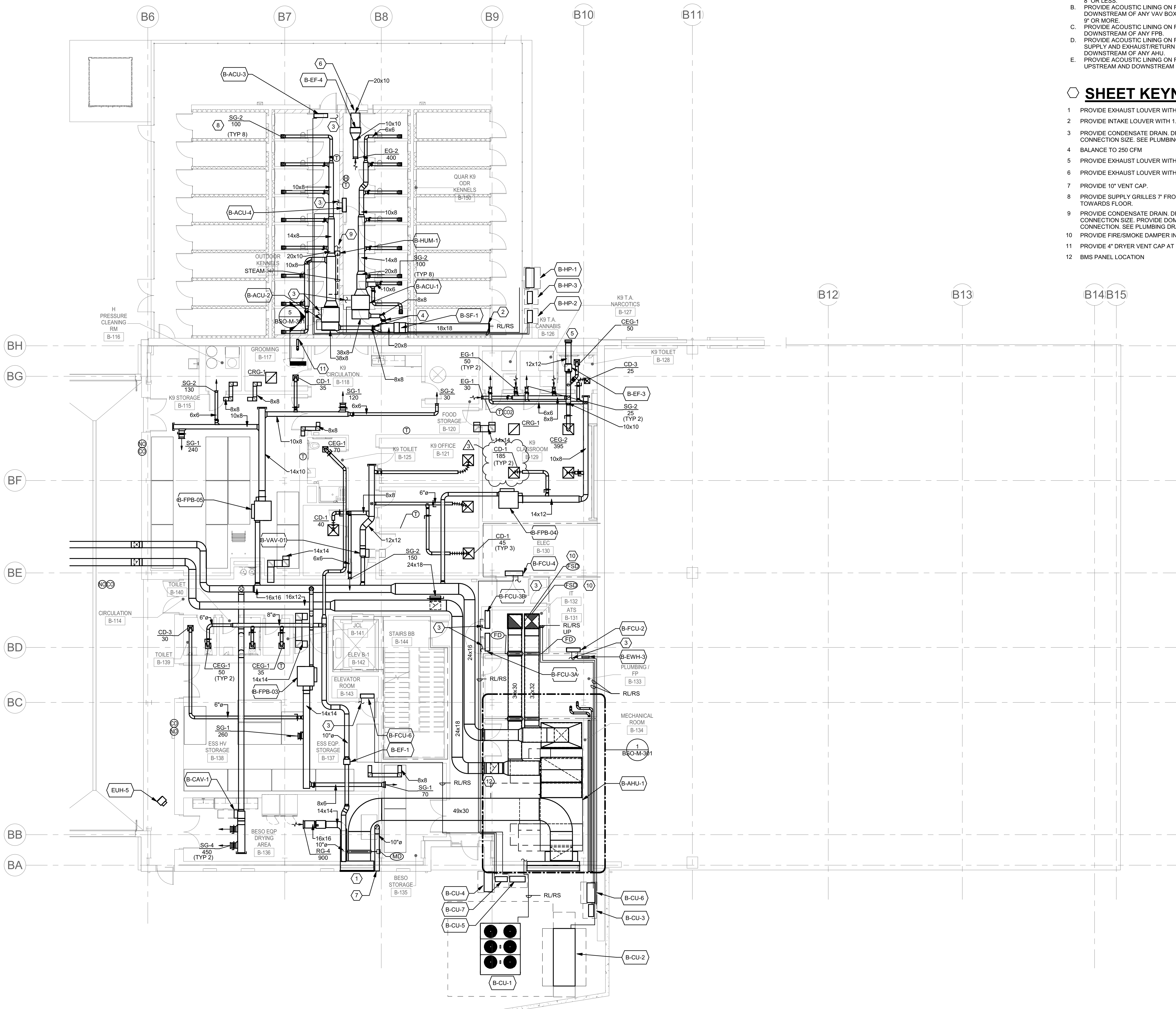

1 FLOOR PART PLAN B - LEVEL 1 - MECHANICAL

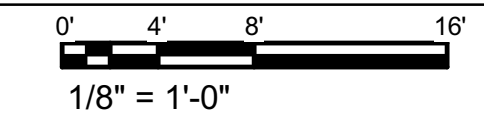

PROJECT: 2021-0159
CONTACT: Keith Pasma
2000 M Street NW, Suite 270
Washington, DC 20036
TEL: 202.370.9555
www.interfaceengineering.com

VERIFY SCALE

BAR IS ONE (1) INCH LONG ON ORIGINAL DRAWING: 1

IF BAR IS NOT ONE (1) INCH LONG, ADJUST SCALE ACCORDINGLY

CONTRACTOR SHALL FIELD VERIFY ALL DIMENSIONS. VARIANCE FROM CONTRACT DOCUMENTS NOT PERMITTED WITHOUT PROFESSIONAL & BUREAU OF CONSTRUCTION APPROVAL.

SHEET No. **BSO-M-111**

DRAWN BY: Author CHECKED BY: Checker DATE: SCALE: AS NOTED

1/8" = 1'-0"

1/8" = 1'-0"

1/8" = 1'-0"

1/8" = 1'-0"

1/8" = 1'-0"

GENERAL SHEET NOTES

- PROVIDE ACOUSTIC LINING ON FIRST 5' OF DUCT DOWNSTREAM OF ANY VAV BOXES WITH SIZES OF 6" OR LESS.
- PROVIDE ACOUSTIC LINING ON FIRST 10' OF DUCT DOWNSTREAM OF ANY VAV BOXES WITH SIZES OF 9" OR MORE.
- PROVIDE ACOUSTIC LINING ON FIRST 15' OF DUCT DOWNSTREAM OF ANY FPB.
- PROVIDE ACOUSTIC LINING ON FIRST 20' OF SUPPLY AND EXHAUST/RETURN DUCT DOWNSTREAM OF ANY AHU.
- PROVIDE ACOUSTIC LINING ON FIRST 10' OF DUCT UPSTREAM AND DOWNSTREAM OF ANY FAN.

SHEET KEYNOTES

- PROVIDE EXHAUST LOUVER WITH 3.15 SOFT FREE AREA.
- PROVIDE INTAKE LOUVER WITH 9.6 SOFT FREE AREA.
- PROVIDE CONDENSATE DRAIN. DRAIN SIZE TO MATCH EQUIPMENT CONNECTION SIZE. SEE PLUMBING DRAWINGS FOR CONTINUATION.
- 4" DRYER EXHAUST THROUGH ROOF. PROVIDE 4" ROOF MOUNTED DRYER VENT CAP.
- PROVIDE 6" CONNECTION TO MOVABLE EXTRACTION ARM. SEE M-402 FOR EXTRACTION ARM SCHEDULE.
- PROVIDE EXHAUST THROUGH ROOF. EXTEND DUCT 3' ABOVE ADJACENT ROOF AND PROVIDE VENT CAP.
- PROVIDE WALL SWITCH CONTROL FOR EXHAUST FAN.

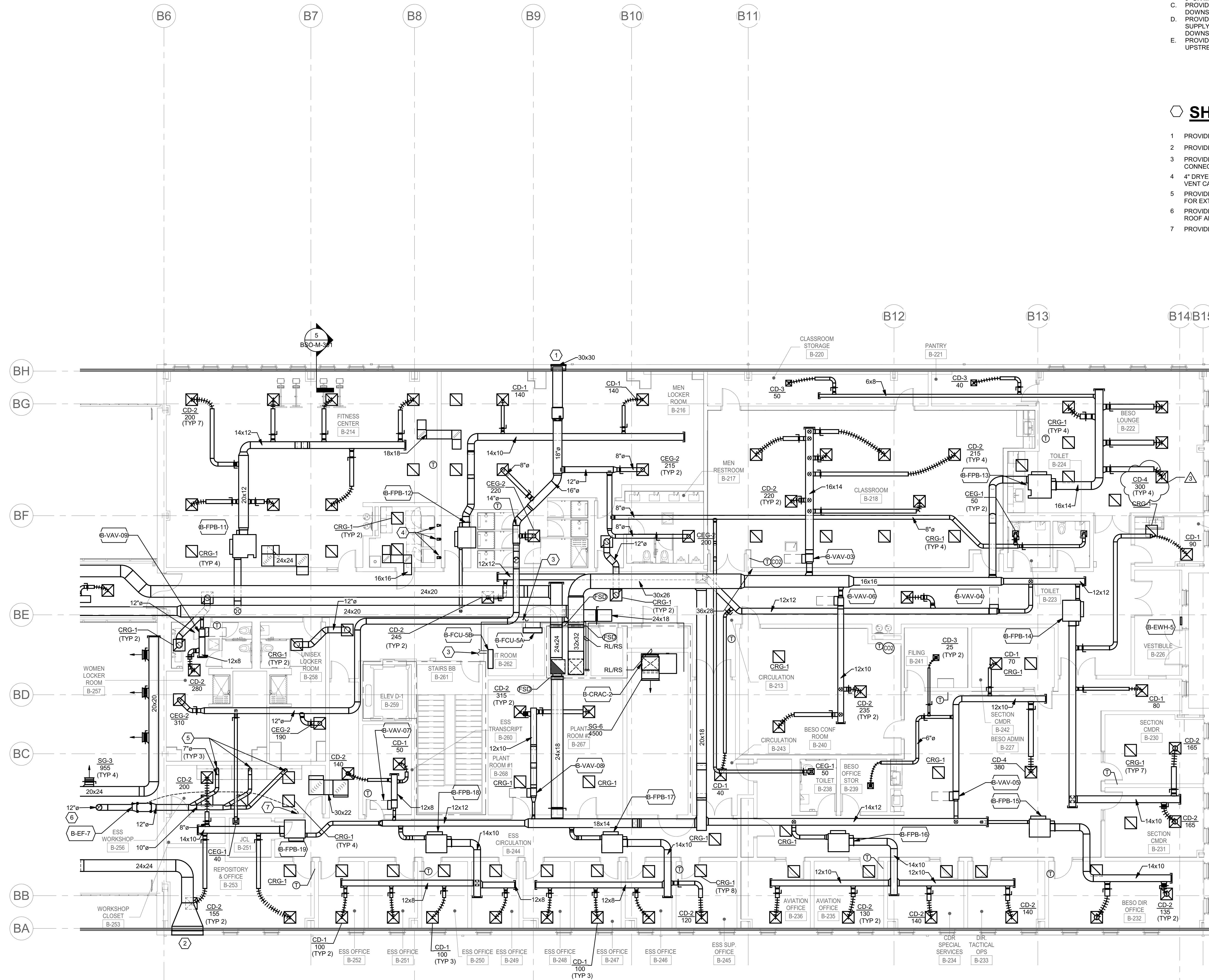

1 FLOOR PART PLAN B - LEVEL 2 - MECHANICAL

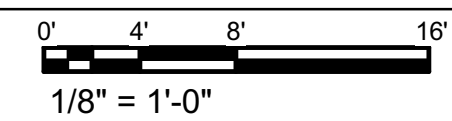

TACTICAL TRAINING DESIGN

Tactical Design North

231 E. Buffalo St #502, Milwaukee, WI 53202

LOCAL ARCHITECT

Jacobs Wyper Architects

1232 Chancellor St, Philadelphia, PA 19107

STRUCTURAL ENGINEER

Skidmore, Owings & Merrill LLP

250 Greenwich St, New York, NY 10007

ELECTRICAL, PLUMBING, FIRE PROTECTION, FIRE ALARM ENGINEER

A & J Consulting Engineering Services, P.C.

164 Brighton Rd, Clifton, NJ 07012

MECHANICAL AVIT ENGINEER

Interface Engineering, Inc.

2000 M Street NW, Suite 270, Washington, DC 20036

ACOUSTICAL ENGINEER

Cerami

1001 Ave of the Americas, 4th Floor, New York, NY 10018

CODE CONSULTING

CCI

215 W 40th St, 10th Floor, New York, NY 10018

CIVIL ENGINEER

Langan

1818 Market St #3300, Philadelphia, PA 19103

VERTICAL TRANSPORT

Michael Blades & Associates Ltd.

5409 Rapiant Ct, Lothian, MD 20711

SIGNAGE CONSULTANT

Patricia Hord Graphik Design

119 S. St. Asaph St, Alexandria, VA 22314

LANDSCAPE

Lee and Associates, Inc.

638 I Street NW, Washington, DC 20001

LIGHTING

MCLA

1000 Potomac St NW, Suite 121, Washington, DC 20007

FOOD SERVICE

Hopkins Foodservice Specialists, Inc.

7906 MacArthur Blvd, Suite 100, Cabin John, MD 20818

COST ESTIMATING

AECOM

1700 Market St, Suite 1600, Philadelphia, PA 19103

KEYPLAN

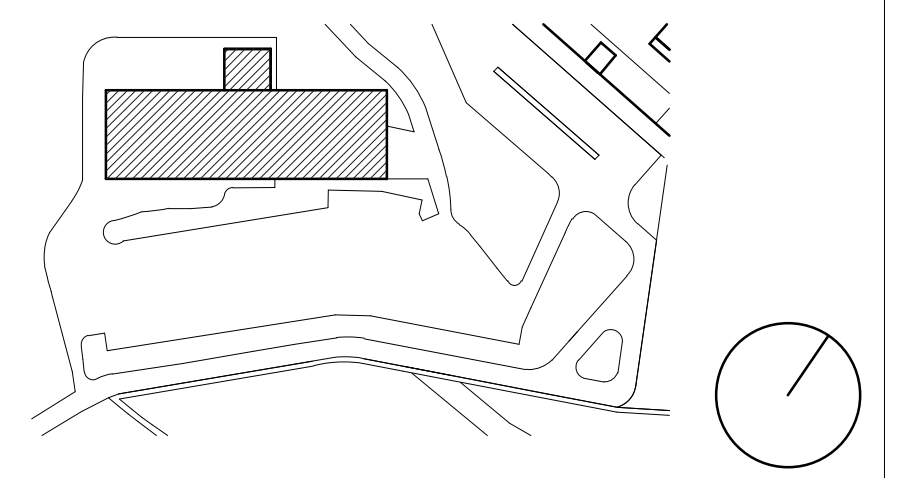

NO.	DATE	DESCRIPTION	NO.	DATE	DESCRIPTION
3	09 JUN 2023	ADDENDUM 26			
2	19 MAY 2023	ISSUED FOR BID			
1	28 JAN 2022	ISSUED TO L&I			

RECORD REVISIONS

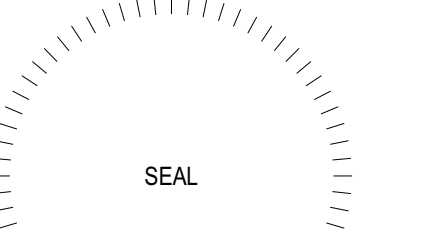

SIGNATURE DATE

ARCHITECT

SOM
Skidmore, Owings & Merrill LLP
250 Greenwich St, New York, 10007

COMMONWEALTH OF PENNSYLVANIA
DEPARTMENT OF GENERAL SERVICES
HARRISBURG, PENNSYLVANIA

D.G.S. PROJECT No.

C-0211-0005 PHASE 5

Pennsylvania State Police Academy
Core Buildings, BESO & Sitework
PENNSYLVANIA STATE POLICE
HERSHEY, DAUPHIN COUNTY, PA

INTERFACE ENGINEERING

PROJECT 2021-0159
CONTACT Keith Pasma
2000 M Street NW, Suite 270
Washington, DC 20036
TEL: 202.370.9555
www.interfaceengineering.com

VERIFY SCALE

BAR IS ONE (1) INCH LONG
ON ORIGINAL DRAWING: 1
IF BAR IS NOT ONE (1) INCH LONG, ADJUST SCALE ACCORDINGLY

CONTRACTOR SHALL FIELD VERIFY ALL DIMENSIONS. VARIANCE FROM CONTRACT DOCUMENTS NOT PERMITTED WITHOUT PROFESSIONAL & BUREAU OF CONSTRUCTION APPROVAL.

SHEET No.

BSO-M-121

DRAWN BY

Author

CHECKED BY

Checker

DATE

SCALE

AS NOTED

FLOOR PART PLAN B - LEVEL 2 -MECHANICAL

FAN POWERED BOX UNIT SCHEDULE (ELECTRIC HEAT)

SYMBOL	LOCATION	BASIS OF DESIGN		COOLING AIR FLOW			HEATING AIR FLOW		SERIES/PARALLEL	FAN			MIN. INLET SP (IN H2O)	DN STREAM SP (IN H2O)	MAX TU SP (IN H2O)	ELECTRIC RESISTANCE HEAT			FAN ELECTRICAL			HEATER ELECTRICAL			MCA	MO CP	MIN SCRR	NOTES
		MFR	MODEL	INLET SIZE	MAX CFM	MIN CFM	CFM	CFM		ESP	MHP	EAT (°F)				LAT (°F)	HTG (KW)	STAGES	VOLTS	PH	FLA	VOLTS	PH	FLA				
B-FPB-01	SERT EOP STORAGE	TITUS	DTFS	10	730	330	330	SERIES	730	0.5	0.25	0.10	0.50	1.00	63	81	4	2	277	1	1.4	480	3	4.8	7.0	15	5	1
B-FPB-02	HDES EOP STORAGE	TITUS	DTFS	12	845	255	255	SERIES	845	0.5	0.25	0.10	0.50	1.00	65	84	5	2	277	1	1.4	480	3	6.0	8.5	15	5	1
B-FPB-03	ESS EOP STORAGE	TITUS	DTFS	8	360	110	110	SERIES	360	0.5	0.25	0.10	0.50	1.00	65	79	1.5	2	277	1	0.8	480	3	1.8	2.8	15	5	1
B-FPB-04	K9 CLASSROOM	TITUS	DTFS	8	445	135	135	SERIES	445	0.5	0.17	0.10	0.50	1.00	65	80	2	1	277	1	0.8	480	3	2.4	3.6	15	5	1
B-FPB-05	K9 STORAGE	TITUS	DTFS	10	555	250	250	SERIES	555	0.5	0.25	0.10	0.50	1.00	63	83	3.5	2	277	1	1.4	480	3	4.2	6.3	15	5	1
B-FPB-06	SERT & HDES ENTRY	TITUS	DTFS	10	630	285	285	SERIES	630	0.5	0.25	0.10	0.50	1.00	63	83	4	2	277	1	1.4	480	3	4.8	7.0	15	5	1
B-FPB-07	HDES ADMIN	TITUS	DTFS	6	280	85	85	SERIES	280	0.5	0.17	0.10	0.50	1.00	65	82	1.5	1	277	1	0.8	480	3	1.8	2.8	15	5	1
B-FPB-08	HDES ADMIN	TITUS	DTFS	10	825	250	250	SERIES	825	0.5	0.25	0.10	0.50	1.00	66	77	3.5	2	277	1	1.4	480	3	4.2	6.3	15	5	1
B-FPB-09	SERT BRIEFING ROOM	TITUS	DTFS	12	1150	345	345	SERIES	1150	0.5	0.33	0.10	0.50	1.00	66	72	2.5	1	277	1	3.0	480	3	3.0	5.9	15	5	1
B-FPB-10	SER ADMIN & TEAM LEAD	TITUS	DTFS	12	900	270	270	SERIES	900	0.5	0.25	0.10	0.50	1.00	66	76	3	1	277	1	1.4	480	3	3.6	5.5	15	5	1
B-FPB-11	FITNESS CENTER	TITUS	DTFS	14	1400	700	700	SERIES	1400	0.5	0.33	0.10	0.50	1.00	63	73	4.5	2	277	1	3.0	480	3	5.4	8.9	15	5	1
B-FPB-12	MEN LOCKER ROOM	TITUS	DTFS	6	280	85	85	SERIES	280	0.5	0.17	0.10	0.50	1.00	65	77	1	1	277	1	0.8	480	3	1.2	2.1	15	5	1
B-FPB-13	BESO LOUNGE	TITUS	DTFS	14	1290	585	585	SERIES	1290	0.5	0.33	0.10	0.50	1.00	63	75	5	2	277	1	3.0	480	3	6.0	9.7	15	5	1
B-FPB-14	CIRCULATION	TITUS	DTFS	8	500	150	150	SERIES	500	0.5	0.25	0.10	0.50	1.00	66	78	2	1	277	1	1.4	480	3	2.4	4.0	15	5	1
B-FPB-15	BESO ADMIN	TITUS	DTFS	6	270	110	110	SERIES	270	0.5	0.17	0.10	0.50	1.00	64	81	1.5	1	277	1	0.8	480	3	1.8	2.8	15	5	1
B-FPB-16	BESO ADMIN	TITUS	DTFS	10	540	220	220	SERIES	540	0.5	0.25	0.10	0.50	1.00	64	79	2.5	1	277	1	1.4	480	3	3.0	4.8	15	5	1
B-FPB-17	ESS CIRCULATION	TITUS	DTFS	8	420	170	170	SERIES	420	0.5	0.17	0.10	0.50	1.00	64	79	2	1	277	1	0.8	480	3	2.4	3.6	15	5	1
B-FPB-18	ESS CIRCULATION	TITUS	DTFS	8	400	160	160	SERIES	400	0.5	0.25	0.10	0.50	1.00	64	76	1.5	1	277	1	0.8	480	3	1.8	2.8	15	5	1
B-FPB-19	ESS CIRCULATION	TITUS	DTFS	8	510	205	205	SERIES	510	0.5	0.25	0.10	0.50	1.00	64	76	2	1	277	1	1.4	480	3	2.4	4.0	15	5	1

NOTES:
1. PROVIDE SCR HEATER CONTROL.

DX FAN COIL SCHEDULE (COOLING ONLY)

SYMBOL	LOCATION	BASIS OF DESIGN		NOM TONS	RELATED CU	DX COOLING COIL					MAX WT (LBS)	NOTES	
		MFR	MODEL			AIR FLOW (CFM)	TOTAL CAP (MBH)	SENS CAP (MBH)	EDB (°F)	EWB (°F)			
B-FCU-2	ATS ROOM	DAIKIN	FTK09AXVJU	0.75	B-CU-3	435	8.9	3.0	80	67	20	1	
B-FCU-3A	IT ROOM	DAIKIN	FTX524AXVJU	2	B-CU-4	645	23.5	15.7	80	67	35	1.2	
B-FCU-3B	IT ROOM	DAIKIN	FTX524AXVJU	2	B-CU-4	645	23.5	15.7	80	67	35	1.2	
B-FCU-4	ELEC	DAIKIN	FTK24AXVJU	2	B-CU-5	715	21.2	15.7	80	67	35	1	
B-FCU-5A	IT ROOM	DAIKIN	FTX524AXVJU	2	B-CU-6	645	23.5	15.7	80	67	35	1.2	
B-FCU-5B	IT ROOM	DAIKIN	FTX524AXVJU	2	B-CU-6	645	23.5	15.7	80	67	35	1.2	
B-FCU-6	ELEVATOR ROOM	DAIKIN	FTK09AXVJU	0.75	B-CU-7	435	8.9	3.0	80	67	20	1	

NOTES:
1. INDOOR FCU POWER FED FROM CU. ONLY ONE ELECTRICAL CONNECTION PER CONDENSING UNIT.
2. UNIT TO BE COOLING ONLY. HEATING MODE TO BE LOCKED OUT.

SPLIT SYSTEM CONDENSING UNIT SCHEDULE (COOLING ONLY)

SYMBOL	LOCATION	BASIS OF DESIGN		RELATED FAN	AIR SOURCE CONDENSER			ELECTRICAL			MIN. SCRR (KAIC)	MAX WT (LBS)	NOTES	
		MFR	MODEL		COOLING CAP (MBH)	AMBIENT DB (°F)	EER/SCOP	VOLTS	PH	MCA				MOCP
B-CU-1	EXTERIOR	DAIKIN	RTK09AXVJU	B-AHU-1	600.0	95	11.6	460	3	102.0	110	5	3325	23.5
B-CU-2	EXTERIOR	DAIKIN	RTK09AXVJU	B-CRAC-2	180.0	95	2.6	460	3	5.7	15	5	900	24.6
B-CU-3	EXTERIOR	DAIKIN	RTK09AXVJU	B-FCU-2	8.9	95	12.5	208	1	7.0	20	5	55	12.5
B-CU-4	EXTERIOR	DAIKIN	RTK09AXVJU	B-FCU-3A & B-FCU-3B	47.0	95	10.5	208	1	33.2	27	5	216	12.5
B-CU-5	EXTERIOR	DAIKIN	RTK09AXVJU	B-FCU-4	21.2	95	12.2	208	1	13.4	20	5	110	12.5
B-CU-6	EXTERIOR	DAIKIN	RTK09AXVJU	B-FCU-5A & B-FCU-5B	47.0	95	10.5	208	1	33.2	27	5	216	12.5
B-CU-7	EXTERIOR	DAIKIN	RTK09AXVJU	B-FCU-6	8.9	95	12.5	208	1	7.0	20	5	55	12.5

NOTES:
1. INDOOR FCU POWER FED FROM CU. ONLY ONE ELECTRICAL CONNECTION PER CONDENSING UNIT.
2. FUSED DISCONNECT PROVIDED BY ELECTRICAL CONTRACTOR.
3. IN COMBINATION WITH ASSOCIATED AIR HANDLING UNIT, PROVIDE MANUFACTURER CONTROL DEVICES REQUIRED FOR FULLY OPERATING SYSTEM.
4. IN COMBINATION WITH ASSOCIATED CRAC UNIT, PROVIDE MANUFACTURER CONTROL DEVICES REQUIRED FOR FULLY OPERATING SYSTEM.
5. LISTED EFFICIENCY SHOWN AS EER.
6. LISTED EFFICIENCY SHOWN AS SCOP UNDER DOE RATING CONDITIONS.

CAV BOX UNIT SCHEDULE (ELECTRIC REHEAT)

SYMBOL	LOCATION	AREA SERVED	BASIS OF DESIGN		ELECTRIC RESISTANCE HEAT					ELECTRICAL					NOTES			
			MFR	MODEL	INLET SIZE	AIR FLOW (CFM)	MIN CFM	EAT (°F)	LAT (°F)	HTG (KW)	STAGES	VOLTS	FLA	MCA		MOCP	PH	
B-CAV-1	BESO EOP DRYING AREA	BESO EOP DRYING AREA	TITUS	DESV	12	900	900	55	75	6	2	480	7.2	9.0	15	3	1	

NOTES:
1. PROVIDE WITH STANDARD DISCONNECT.

SHUT OFF VAV BOX UNIT SCHEDULE

SYMBOL	LOCATION	BASIS OF DESIGN		AIR FLOW		NOTES
		MFR	MODEL	INLET SIZE	MAX CFM	
B-VAV-01	K9 STORAGE	TITUS	DESV	8	325	165
B-VAV-03	CLASSROOM	TITUS	DESV	12	1300	390
B-VAV-04	CIRCULATION	TITUS	DESV	9	530	270
B-VAV-05	BESO ADMIN	TITUS	DESV	8	500	250
B-VAV-06	CONFERENCE	TITUS	DESV	9	470	140
B-VAV-07	TRANSCRIPT	TITUS	DESV	5	190	100
B-VAV-08	BREAKOUT	TITUS	DESV	10	630	190
B-VAV-09	WOMENS LOCKER	TITUS	DESV	6	280	90

UNIT HEATER SCHEDULE

SYMBOL	LOCATION	SERVING	BASIS OF DESIGN		ELECT RESIST HTG (KW)	ELECTRICAL				EMERG POWER (Y/N)	MAX WT (LBS)	NOTES
			MFR	MODEL		VOLTS	PH	MCA	MOCP			
B-EDH-1	GARAGE	GARAGE	MARKEL	HF	14	480	3	16.9	20	N	1	
B-EWH-1	STAIR BA	STAIR BA	INDEECO	WRI	1	120	1	8.7	15	N	9	1.2
B-EWH-3	PLUMBING/FP	PLUMBING/FP	INDEECO	WRI	1.5	120	1	12.9	15	N	9	1.2
B-EWH-5	VESTIBULE	VESTIBULE	INDEECO	WRI	1	120	1	8.7	15	N	9	1.2
EUH-1	GARAGE	GARAGE	REZNOR	EGEB	7.5	480	3	9.0	15	N	67	1.2
EUH-2	GARAGE	GARAGE	REZNOR	EGEB	7.5	480	3	9.0	15	N	67	1.2
EUH-3	GARAGE	GARAGE	REZNOR	EGEB	7.5	480	3	9.0	15	N	67	1.2
EUH-4	GARAGE	GARAGE	REZNOR	EGEB	7.5	480	3	9.0	15	N	67	1.2
EUH-5	GARAGE	GARAGE	REZNOR	EGEB	7.5	480	3	9.0	15	N	67	1.2

NOTES:
1. PROVIDE WITH INTEGRAL DISCONNECT.
2. PROVIDE TAMPERPROOF INTEGRAL THERMOSTAT SET TO 65 DEG F (ADJUSTABLE).

FAN SCHEDULE

SYMBOL	LOCATION	AREA SERVED	BASIS OF DESIGN		TYPE	DRIVE	AIR FLOW (CFM)	ESP (IN H2O)	MAX RPM	SOUNDS SONES	ELECTRICAL				MIN. SCRR (KAIC)	VFD	MAX WT (LBS)	NOTES
			MFR	MODEL							VOLTS	PH	BHP	MHP				
B-EF-1	ESS EOP STORAGE	LEVEL 1 RESTROOMS	GREENHECK	CSP-A390-VG	INLINE	VARI-GREEN	270	0.5	1750	2	115	1	.08	0.1	5	N	24	12.3
B-EF-2	MEN LOCKER ROOM	LEVEL 2 LOCKER ROOMS	GREENHECK	SQ-140-VG	INLINE	VARI-GREEN	1540	0.5	1500	9	115	1	.26	0.75	5	N	90	12.3
B-EF-3	K9 CLASSRM STORAGE	K9 CLASSROOM	GREENHECK	SQ-95-VG	INLINE	VARI-GREEN	575	0.5	1725	8.5	115	1	.12	0.17	5	N	50	12.3
B-EF-4	QUAR KENNEL CIRCULATION	QUAR KENNEL	GREENHECK	CSP-A700-VG	INLINE	VARI-GREEN	400	0.5	1750	1.2	115	1	.10	0.33	5	N	40	12.3
B-EF-5	GUN CLEANING AREA	GUN CLEANING AREA	GREENHECK	AX-47-190-0412	INLINE	BELT	3100	2.75	3500	47	460	3	2.7	5	5	Y	145	12.4,5
B-EF-6	BESO EOP DRYING AREA	BESO EOP DRYING AREA	GREENHECK	SQ-100-VG	INLINE	VARI-GREEN	900	0.5	1725	7.8	115	1	.14	0.25	5	N	45	12.3
B-EF-7	ESS WORKSHOP	ESS WORKSHOP	GREENHECK	QEI-12	INLINE	BELT	1680	2.75	4000	17.6	460	3	1.43	2	5	Y	240	12.6
B-EF-1	INDOOR KENNELS	KENNELS	GREENHECK	CSP-A700-VG	INLINE	VARI-GREEN	515	0.5	1750	1.2	115	1	.14	0.33	5	N	40	12.3

NOTES:
1. PROVIDE WITH STANDARD DISCONNECT.
2. PROVIDE WITH VIBRATION ISOLATION.
3. PROVIDE WITH ECM MOTOR.
4. INTERLOCK WITH B-AHU-1.
5. PROVIDE WALL SWITCH AND TIMED CONTROL. FAN AND INTERLOCKED EQUIPMENT TO SHUT DOWN AFTER 2 HOURS OF OPERATION.
6. PROVIDE WALL SWITCH CONTROL.

AIR HANDLING UNIT SCHEDULE - COILS

SYMBOL	LOCATION	AREA SERVED	BASIS OF DESIGN		DX COOLING COIL					AUX HEAT	ELEC HEAT ELECTRICAL			HEAT RECOVERY WINTER		HEAT RECOVERY SUMMER		HEAT RECOVERY ELECTRICAL																		
			MFR	MODEL	TOTAL CAP (MBH)	SENS CAP (MBH)	EDB (°F)	EWB (°F)	LDB (°F)		LWB (°F)	FACE VELOCITY (FPM)	APD (IN H2O)	RELATED CU	ELECT. RESIST. HTG (KW)	EDB (°F)	LDB (°F)	VOLTS	PH	FLA	MCA	MOCP	TYPE	SA EAT	SA LAT	EA EAT	EA LAT	SA EAT	SA LAT	EA EAT	EA LAT	VOLTS	PH	FLA	MCA	MOCP
B-AHU-1	MECHANICAL ROOM	BESO	TRANE	CSAA030	646.3	423.3	80.6	66.98	53.96	52.26	490	0.487	B-CU-1	79	42	67	460	3	99.37	99.4	100	WHEEL	11	49.58	70	18.29	92	80.60	75	89.88	115	1	1.3	1.6	15	5

AIR HANDLING UNIT SCHEDULE CONT. - FANS + FILTERS

SYMBOL	LOCATION	AREA SERVED	BASIS OF DESIGN		SUPPLY FAN					EXHAUST FAN					PRE-FILTER	FINAL FILTER	SUPPLY FAN ELECTRICAL			EXHAUST FAN ELECTRICAL			ELECTRICAL			MAX WT (LBS)	NOTES
			MFR	MODEL	TOTAL CFM																						

COMPUTER ROOM AIR CONDITIONING UNIT SCHEDULE

SYMBOL	LOCATION	AREA SERVED	BASIS OF DESIGN		AIR FLOW (CFM)	FAN ESP (IN H2O)	COOLING CAPACITY				HUMIDIFIER STEAM CAP (LB/HR)	REHEAT (KW)	SA FAN (HP)	ELECTRICAL					MIN. SCOR (KAIC)	MAX WT (LBS)	NOTES
			MFR	MODEL			TOTAL (MBH)	SENS (MBH)	EAT DB (°F)	EAT WB (°F)				VOLTS	PH	FLA	MCA	MOCPP			
B-CRAC-1	SERT EQP STORAGE	ARMS STORAGE & AMMO STORAGE	LIEBERT	MM12E	600	0.3	12.0	11.0	75	61	2.5	4.8	0.2	277	1	26.7	31.8	35	5	220	1,2,3
B-CRAC-2	LEVEL 2 MECHANICAL ROOM	ESS SECURE SERVER ROOM	DATA AIRE	GUAAU-04934	4500	0.5	173.0	131.0	75	61	10.0	15	3.4	460	3	50.6	62.4	80	5	1600	1,2,3,4,5

NOTES:
 1. PROVIDE SCR REHEAT.
 2. PROVIDE SELF CONTAINED UNIT.
 3. PROVIDE FACTORY INSTALLED STEAM GENERATING HUMIDIFIER.
 4. PROVIDE REAR RETURN OPTION (OPT-6341).
 5. PROVIDE LIMITED SIDE CLEARANCE OPTION.

ENERGY RECOVERY UNIT SCHEDULE

SYMBOL	LOCATION	SERVING	BASIS OF DESIGN		SUPPLY FAN					EXHAUST FAN					HEAT EXCHANGER						EXHAUST FILTER	OA FILTER	ELECTRICAL			APPROX. DIM (LxWxH)	MAX WT (LBS)	NOTES					
			MFR	MODEL	TOTAL CFM	ESP (IN H2O)	BHP	HP	FRPM	VFD (Y/N)	TOTAL CFM	ESP (IN H2O)	BHP	HP	FRPM	VFD (Y/N)	TYPE	WINTER					SUMMER										
			SA EAT (°F)	EA EAT (°F)	EA LAT (°F)	SA EAT (°F)	SA LAT (°F)	EA EAT (°F)	EA LAT (°F)	EFF MERV	EFF MERV	MCA	VOLTS	PH																			
B-ERV-1	GARAGE	GARAGE	GREENHECK	ERV-45-INDOOR	4230	0.4	4.1	5	1725	Y	4230	0.5	4.47	5	1725	Y	WHEEL	6	43	55	17	92	87	85	91	8	8	17.7	460	3	67X67X45	920	1,2,3

NOTES:
 1. INTERLOCK WITH GARAGE CO AND NO SENSORS.
 2. PROVIDE WITH PREWIRED STANDARD DISCONNECT.
 3. PROVIDE WITH PREWIRED STANDARD DISCONNECT.
 4. VFD SHALL ALLOW FANS TO SLOW TO MINIMUM FLOW OF 2000 CFM.

HVLS FAN SCHEDULE

SYMBOL	LOCATION	AREA SERVED	BASIS OF DESIGN		DIAMETER (FT)	MAX RPM	ELECTRICAL				MAX WT (LBS)	NOTES
			MFR	MODEL			VOLTS	PH	MHP	MIN. SCOR (KAIC)		
B-HVLS-1	GARAGE	SOUTH BAY	Big Ass Fans	Basic 6	16	76	480	3	2	5	205	1,2,3
B-HVLS-2	GARAGE	NORTH BAY	Big Ass Fans	Basic 6	16	76	480	3	2	5	205	1,2,4

NOTES:
 1. PROVIDE WITH PREWIRED STANDARD DISCONNECT.
 2. PROVIDE WITH MANUFACTURER CONTROLS.
 3. MOUNT FOR BLADE LEVEL TO BE 33' ABOVE FINISHED FLOOR.
 4. MOUNT FOR BLADE LEVEL TO BE 31.5' ABOVE FINISHED FLOOR.

DIFFUSER, REGISTER AND GRILLE SCHEDULE

SYMBOL	BASIS OF DESIGN		TYPE	FACE DIMENSIONS (IN)	ROUND NECK SIZE (IN)	AIRFLOW		MAX PRESSURE DROP	NOTES
	MFR	MODEL				MIN (CFM)	MAX (CFM)		
CEG-1	TITUS	OMNI	CEILING EXHAUST DIFFUSER	12X12	8	0	100	0.10	1-9
CEG-2	TITUS	OMNI	CEILING EXHAUST DIFFUSER	24X24	8	0	320	0.10	1-9
CRG-1	TITUS	OMNI	CEILING RETURN GRILLE	24X24	12	0	500	0.10	1-9
CD-1	TITUS	OMNI	CEILING SUPPLY DIFFUSER	24X24	6	0	200	0.10	1-9
CD-2	TITUS	OMNI	CEILING SUPPLY DIFFUSER	24X24	8	150	315	0.10	1-9
CD-3	TITUS	OMNI	CEILING SUPPLY DIFFUSER	12X12	6	0	100	0.10	1-9
CD-4	TITUS	OMNI	CEILING SUPPLY DIFFUSER	24X24	10	220	420	0.10	1-9
EG-1	TITUS	350RL	EXHAUST WALL GRILLE	6X6	-	0	100	0.10	1-9
EG-2	TITUS	350RL	EXHAUST WALL GRILLE	10X10	-	0	400	0.10	1-9
RG-1	TITUS	350RL	RETURN WALL GRILLE	18X18	-	0	1400	0.10	1-9
RG-2	TITUS	350RL	RETURN WALL GRILLE	12X10	-	0	500	0.10	1-9
RG-3	TITUS	350RL	RETURN WALL GRILLE	8X6	-	0	180	0.10	1-9
RG-4	TITUS	350RL	RETURN WALL GRILLE	16X16	-	0	1000	0.10	1-9
SG-1	TITUS	300FL	SUPPLY WALL GRILLE	12x6	-	0	290	0.10	1-9
SG-2	TITUS	300FL	SUPPLY WALL GRILLE	6x6	-	0	130	0.10	1-9
SG-3	TITUS	300FL	SUPPLY WALL GRILLE	18X18	-	0	1450	0.10	1-9
SG-4	TITUS	300FL	SUPPLY WALL GRILLE	12x10	-	0	500	0.10	1-9
SG-5	TITUS	300FL	SUPPLY WALL GRILLE	36X20	-	1600	3600	0.10	1-9
SG-6	TITUS	300FL	SUPPLY WALL GRILLE	36X28	-	2000	4500	0.10	1-9

NOTES:
 1. COORDINATE EXACT LOCATION WITH LIGHTS, SPRINKLER HEATS, AND ARCH. RCP. INDICATE ON SHOP DRAWINGS.
 2. COORDINATE WITH ARCHITECTURAL PLANS AND REFLECTED CEILING PLANS FOR BORDER TYPES.
 3. COORDINATE WITH WALL ELEVATIONS.
 4. PROVIDE REMOTE CONTROL RODS FOR VOLUME DAMPER WHEN INSTALLED ABOVE INACCESSIBLE CEILING.
 5. PROVIDE GRILLE/DIFFUSER WITH MAXIMUM TOTAL PRESSURE DROP OF 0.1" W.G.
 6. PROVIDE GRILLE/DIFFUSER WITH MAXIMUM SOUND POWER LEVEL NC 30.
 7. SIZE OF DUCT TAKEOFF, BRANCH DUCTS, AND FLEX DUCT TO MATCH THE NECK SIZE OD THE ASSOCIATED DIFFUSER/GRILLE UNLESS OTHERWISE NOTED.
 8. CFM SHOWN ON PLANS.
 9. PROVIDE ALL SUPPLY AND RETURN/EXHAUST GRILLES AND DIFFUSERS WITH A BALANCE DAMPER AT BRANCH TAKEOFF UNLESS OTHERWISE NOTED.

HUMIDIFIER SCHEDULE

SYMBOL	SERVING	BASIS OF DESIGN		MAX STEAM CAP (LBS/HR)	SPACE TEMP (°F)	SPACE % RH DESIGN	ELECTRICAL				APPROX. DIMENSIONS (HxWxL)	MAX WT (LBS)	COMMENTS	
		MFR	MODEL				VOLTS	PH	MCA	MOCPP				
B-HUM-1	KENNELS	NEPTRONIC	SKR14	4.5	80	50	120	1	12.0	15	5	14.5X10.5X9	35	1

NOTES:
 1. PROVIDE REMOTE DUCT MOUNTED DISTRIBUTION UNIT.

SPLIT SYSTEM CONDENSING UNIT SCHEDULE

SYMBOL	LOCATION	AREA SERVED	BASIS OF DESIGN		RELATED FAN	AIR SOURCE HEAT PUMP CONDENSER					ELECTRICAL					MAX WT (LBS)	NOTES	
			MFR	MODEL		COOLING		HEATING			VOLTS	PH	MCA	MOCPP	MIN. SCOR (KAIC)			
			CAP (MBH)	AMBIENT DB (°F)		EER	CAP (MBH)	AMBIENT WB (°F)	COP									
B-HP-1	EXTERIOR	KENNELS	DAIKIN	RMXSR8TUJU	B-ACU-1 & B-ACU-2	47.0	95	10.5	48.5	47	3.9	208	1	33.2	35	5	220	1,2
B-HP-2	EXTERIOR	KENNELS	DAIKIN	RK09AXVJU	B-ACU-3	9.0	95	12.5	10.9	47	4.2	208	1	9.5	15	5	60	1,2,3
B-HP-3	EXTERIOR	KENNELS	DAIKIN	RK09AXVJU	B-ACU-3	9.0	95	12.5	10.9	47	4.2	208	1	9.5	15	5	60	1,2,3
B-HP-4	EXTERIOR	GUN CLEANING AREA	MITSUBISHI	TUHYE168	B-MAU-1	168.0	95	11.7	188.0	47	3.61	460	3	25.0	40	5	790	2,3

NOTES:
 1. INDOOR ACU POWER FED FROM HP. ONLY ONE ELECTRICAL CONNECTION PER HP.
 2. FUSED DISCONNECT PROVIDED BY ELECTRICAL CONTRACTOR.
 3. PROVIDE EMERGENCY POWER.

DX FAN COIL SCHEDULE

SYMBOL	LOCATION	SERVING	BASIS OF DESIGN		NOM TONS	RELATED CU	DX COOLING COIL					DX HEATING COIL					MAX WT (LBS)	NOTES
			MFR	MODEL			AIR FLOW (CFM)	MIN OSA	FAN ESP (IN H2O)	TOTAL CAP (MBH)	SENS CAP (MBH)	EDB (°F)	EWB (°F)	TOTAL CAP (MBH)	EDB (°F)	EWB (°F)		
			CAP (MBH)	AMBIENT DB (°F)			EER	CAP (MBH)	AMBIENT WB (°F)	COP								
B-ACU-1	KENNELS	KENNELS	DAIKIN	FDM02ARVJU	2	B-HP-1	800	250	0.6	24.0	0.0	80	67	24.0	70	80	82	1
B-ACU-2	KENNELS	KENNELS	DAIKIN	FDM02ARVJU	2	B-HP-1	800	250	0.6	24.0	0.0	80	67	24.0	70	80	82	1
B-ACU-3	KENNELS	KENNELS	DAIKIN	FTK09AXVJU	75	B-HP-2	415	0	0	9.0	8.2	80	67	24.0	70	80	82	1
B-ACU-4	KENNELS	KENNELS	DAIKIN	FTK09AXVJU	75	B-HP-2	415	0	0	9.0	8.2	80	67	24.0	70	80	82	1

NOTES:
 1. INDOOR ACU POWER FED FROM HP. ONLY ONE ELECTRICAL CONNECTION PER HP.

MAKE-UP AIR UNIT SCHEDULE

SYMBOL	LOCATION	AREA SERVED	BASIS OF DESIGN		DX COIL										ELECTRICAL					MIN. SCOR (KAIC)	MAX WT (LBS)	NOTES						
			MFR	MODEL	COOLING					HEATING					VOLTS	PH	MCA	MOCPP										
			SUPPLY FAN BHP	SUPPLY FAN HP	AIR FLOW (CFM)	FAN ESP (IN H2O)	TOTAL CAP (MBH)	SENSIBLE CAP (MBH)	EDB (°F)	EWB (°F)	LDB (°F)	LWB (°F)	TOTAL CAP (MBH)	EDB (°F)					LDB (°F)				APD (INWG)					
B-MAU-1	SERT EQP STORAGE	GUN CLEANING AREA	TRANE	UCCAG08	2.137	3	3000	0.5	154.0	90.7	92	75	64.54	60.92	88.8	11	38	152	B-HP-4	26	8	460	3	47.2	70	5	650	1-7

NOTES:
 1. PROVIDE WITH NON-FUSED DISCONNECT.
 2. PROVIDE WITH INTERNALLY FED SERVICE RECEPTACLE.
 3. PROVIDE WITH MANUFACTURER'S CENTRALIZED CONTROLS CAPABLE OF BAGNET INTEGRATION WITH BMS.
 4. PROVIDE WITH DIRECT DRIVE FAN AND FACTORY INSTALLED VFD.
 5. PROVIDE WITH RAWAL APR HOT GAS BYPASS VALVE ON LEAD CIRCUIT.
 6. PROVIDE AUX HEATING COIL WITH SSR CONTROL.
 7. INTERLOCK OPERATION WITH B-EP-5.

OUTSIDE AIR VENTILATION SCHEDULE - B-ACU-1/B-ACU-2

BUILDING LOCATION	ROOM	Az NET OCCUPIABLE FLOOR AREA (SF)	Rp PEOPLE OUTDOOR AIR RATE (CFM / PERSON)	Ra AREA OUTDOOR AIR FLOW RATE (CFM/SQ.FT)	DEFAULT OCCUPANT DENSITY (#/1000SF)	DEFAULT ZONE POPULATION	ACTUAL ZONE POPULATION	NUMBER OF DOGS	Vbz BREATHING ZONE OUTDOOR AIRFLOW (CFM)	EZ ZONE AIR DISTRIBUTION EFFECTIVENESS	Voz ZONE OUTDOOR AIRFLOW (CFM)	OSA PROVIDED (CFM)
GROUND LEVEL	B-144 K9 CIRCULATION	330	0	0.06	0	0	0	0	20	0.8	25	25
	P-145 INDOOR KENNELS	250	0	0.00	0	0	0	8	240	N/A	240	240
	P-147 QUAR K9 CIRCULATION	105	0	0.06	5	1	1	1	6	0.8	8	10
	P-148 QUAR K9 INDR KENNELS	120	0	0.00	0	0	0	4	120	N/A	120	120
	P-150 INDOOR KENNELS	125	0	0.00	0	0	0	4	120	N/A	120	120
NOTES:		930									TOTAL	515

1. VENTILATION RATES BASED ON 2015 PENNSYLVANIA MECHANICAL CODE AND PENNSYLVANIA CODE 28a COMMERCIAL KENNEL CANINE HEALTH REGULATIONS.

TACTICAL TRAINING DESIGN

Tactical Design North
 231 E. Buffalo St #502, Milwaukee, WI 53202

LOCAL ARCHITECT

Jacobs Wyper Architects
 1232 Chancellor St, Philadelphia, PA 19107

STRUCTURAL ENGINEER

Skidmore, Owings & Merrill LLP
 250 Greenwich St, New York, NY 10007

ELECTRICAL, PLUMBING, FIRE PROTECTION, FIRE ALARM ENGINEER

A & J Consulting Engineering Services, P.C.
 164 Brighton Rd, Clifton, NJ 07012

MECHANICAL AVIATION ENGINEER

Interface Engineering, Inc.
 2000 M Street NW, Suite 270, Washington, DC 20036

ACOUSTICAL ENGINEER

Cerami
 1001 Ave of the Americas, 4th Floor, New York, NY 10018

CODE CONSULTING

CCI
 215 W 40th St, 10th Floor, New York, NY 10018

CIVIL ENGINEER

Langan
 1818 Market St #3300, Philadelphia, PA 19103

VERTICAL TRANSPORT

Michael Blades & Associates Ltd.
 5409 Rapanan Ct, Lothian, MD 20711

SIGNAGE CONSULTANT

Patricia Hord Graphik Design
 119 S. St. Asaph St, Alexandria, VA 22314

LANDSCAPE

Lee and Associates, Inc.
 6381 I Street NW, Washington, DC 20001

LIGHTING

MCLA
 1000 Patomac St NW, Suite 121, Washington, DC 20007

FOOD SERVICE

Hopkins Foodservice Specialists, Inc.
 7906 MacArthur Blvd, Suite 100, Cabin John, MD 20818

COST ESTIMATING

AECOM
 1700 Market St, Suite 1600, Philadelphia, PA 19103

KEYPLAN

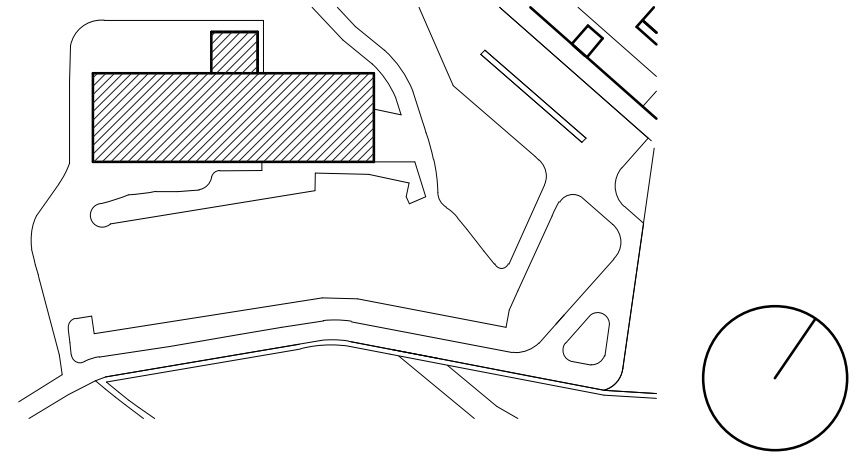

NO.	DATE	DESCRIPTION	NO.	DATE	DESCRIPTION
3	29 JUN 2023	ADDENDUM 26			
2	19 MAY 2022	ISSUED FOR BID			
1	28 JAN 2022	ISSUED TO L&I			

NO.	DATE	DESCRIPTION	NO.	DATE	DESCRIPTION
RECORD REVISIONS					

SIGNATURE _____ DATE _____

ARCHITECT
SOM
 Skidmore, Owings & Merrill LLP
 250 Greenwich St, New York, 10007

COMMONWEALTH OF PENNSYLVANIA
 DEPARTMENT OF GENERAL SERVICES
 HARRISBURG, PENNSYLVANIA

D.G.S. PROJECT No. C-0211-0005 PHASE 5
 Pennsylvania State Police Academy
 Core Buildings, BESO & Sitework
 PENNSYLVANIA STATE POLICE
 HERSHEY, DAUPHIN COUNTY, PA

VERIFY SCALE
 BAR IS ONE (1) INCH LONG
 ON ORIGINAL DRAWING: 1
 IF BAR IS NOT ONE (1) INCH LONG, ADJUST SCALE ACCORDINGLY

SHEET No. **BSO-M-402**
 DRAWN BY: Author
 CHECKED BY: Checker
 DATE: _____
 SCALE: AS NOTED

INTERFACE ENGINEERING
 PROJECT: 2021-0159
 CONTACT: Keith Pasma
 2000 M Street NW, Suite 270
 Washington, DC 20036
 TEL: 202-370-9555
 www.interfaceengineering.com

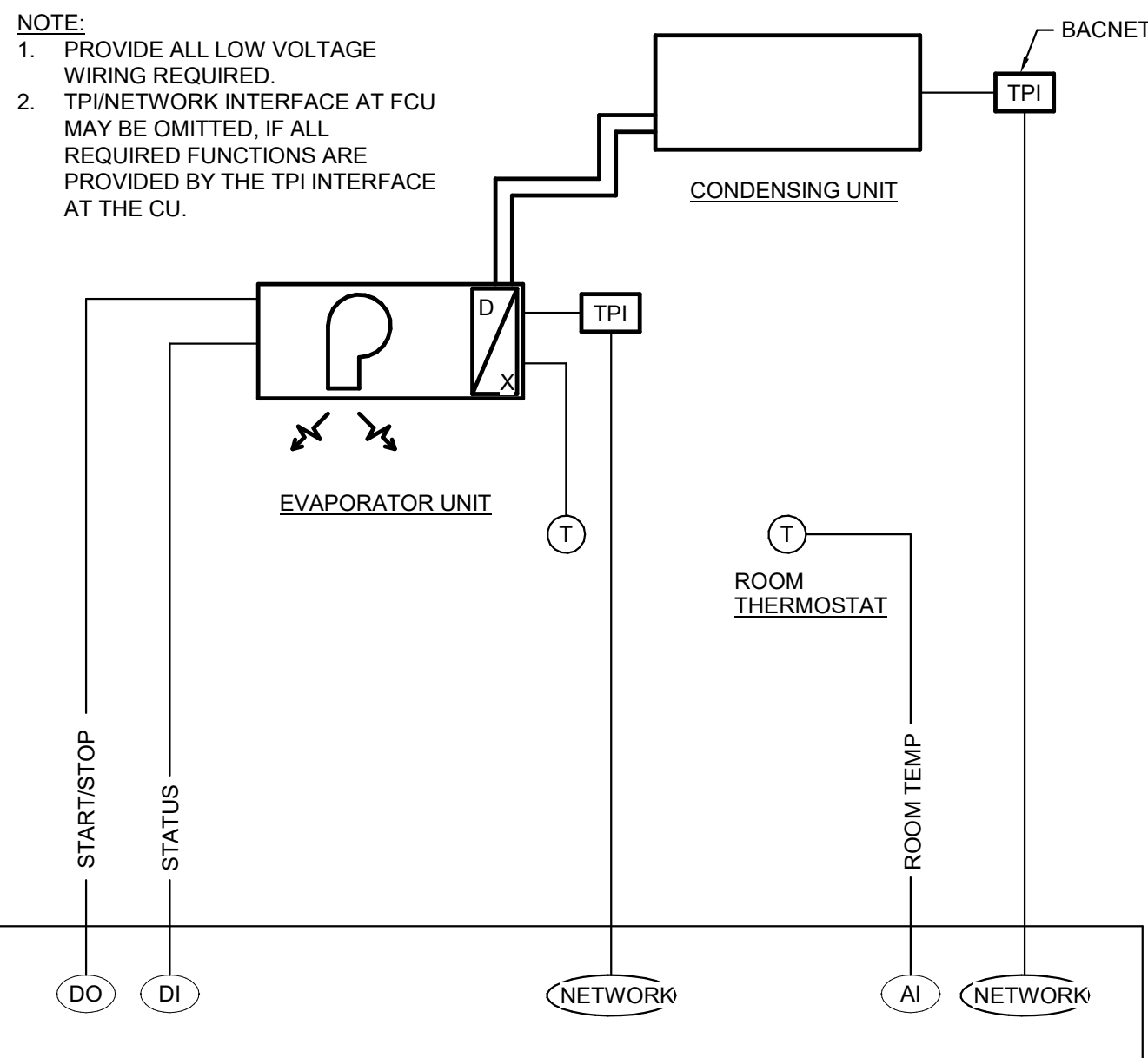

- 1. GENERAL:**
- CONNECT TO THE UNIT'S CONTROLLER AND OPERATE UNIT AS INITIATED FROM BAS SCHEDULE.
 - EACH UNIT'S CONTROLLER WILL MONITOR AND CONTROL ITS FULL RANGE OF OPERATIONS. FAN RUNS CONTINUOUSLY, INCLUDING BOOSTER FANS, IF APPLICABLE. DETERMINE FAN SPEED TO DELIVER THE LOWEST AIR QUANTITY POSSIBLE BY THE SYSTEM TO MEET THE COOLING SETPOINT.
 - OPERATE FAN COIL UNITS AT THE FOLLOWING SETPOINT TEMPERATURES:
 - COOLING: 80°F (ADJ.)
 - GENERATE AN ALARM AT THE BAS WHEN THE SPACE TEMPERATURE EXCEEDS THE SETPOINT BY +5°
 - CREATE A GRAPHICAL SCREEN FOR EACH VARIABLE REFRIGERANT FLOW SYSTEM, INCLUDING ALL CONNECTED FAN COILS AND CONDENSING UNITS, AND:
 - PROVIDE ABILITY OF INDIVIDUAL OR GLOBAL CHANGES TO:
 - TEMPERATURE SETPOINTS.
 - FAN SPEED.
 - FORCED SHUT DOWN OF COOLING (IE THE FAN CONTINUES OPERATION)
 - OPERATION MODE SETTING: COOL/FAN/DRY/AUTO.
 - FORCED SYSTEM STOP.
 - MONITOR THE FOLLOWING ADDITIONAL POINTS IN THE SYSTEM'S GRAPHICAL SCREEN:
 - UNIT ALARM.
 - MALFUNCTION CODE.
 - FILTER ALARM.
 - THERMO-ON STATUS (WHETHER THE UNIT IS ACTIVELY HEATING OR COOLING).
 - COMPRESSOR STATUS.
 - FAN STATUS.
 - COMMUNICATION STATUS.
 - REMOTE CONTROLLER PROHIBIT STATUS.

1 VRF & SPLIT SYSTEM CONTROL DIAGRAM
NO SCALE

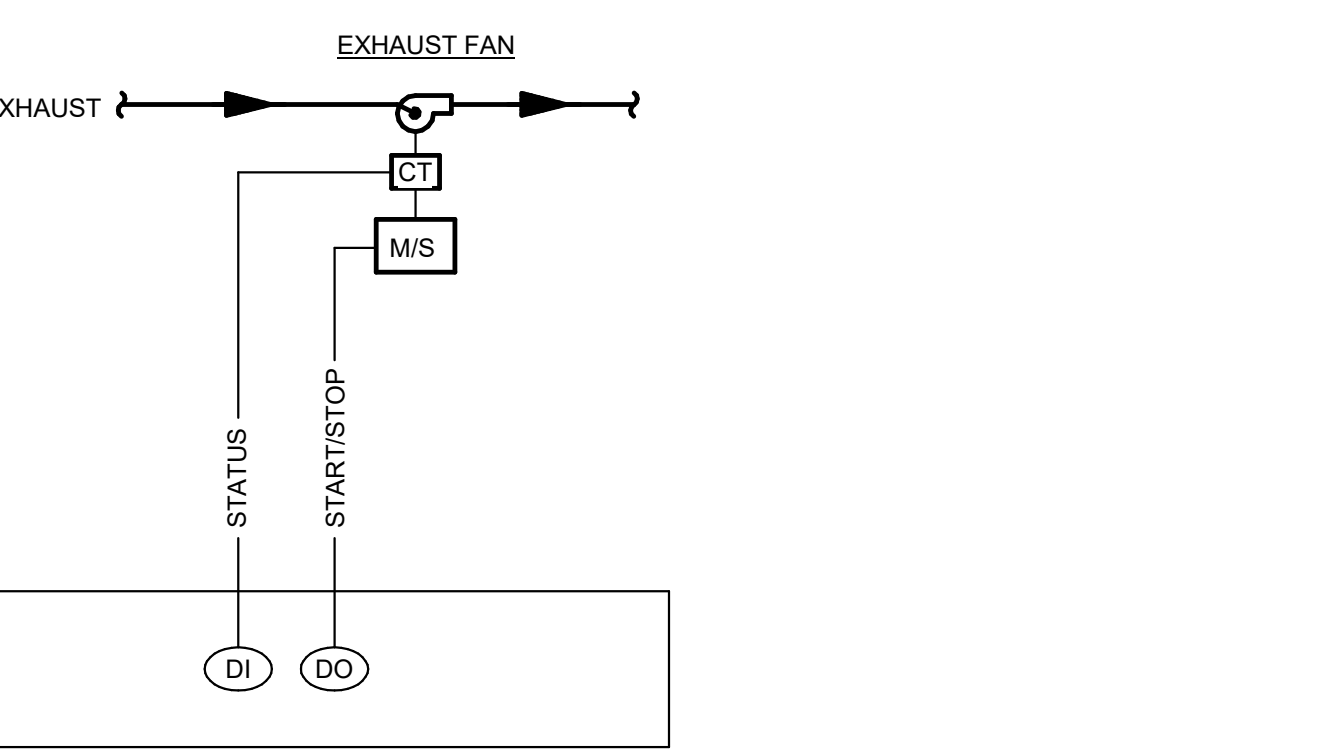

- MONITOR EC MOTORS FROM POINTS INDICATED ON CONTROL DIAGRAMS AND THROUGH COMMUNICATIONS PORT ON EACH MOTOR. AS MINIMUM, MONITOR AND/OR REPORT THE FOLLOWING POINTS:
 - MOTOR SPEED
 - RUNTIME - HOURS
 - SYSTEM FAULT
 - MOTOR STATUS
- GENERATE AN ALARM IF STATUS IS LOST FOR MORE THAN 1 MINUTE, MOTOR FAULT, MOTOR FAILURE, IS OFF, OR IN HAND.

2 MOTOR W/ STARTER (TYPICAL)
NO SCALE

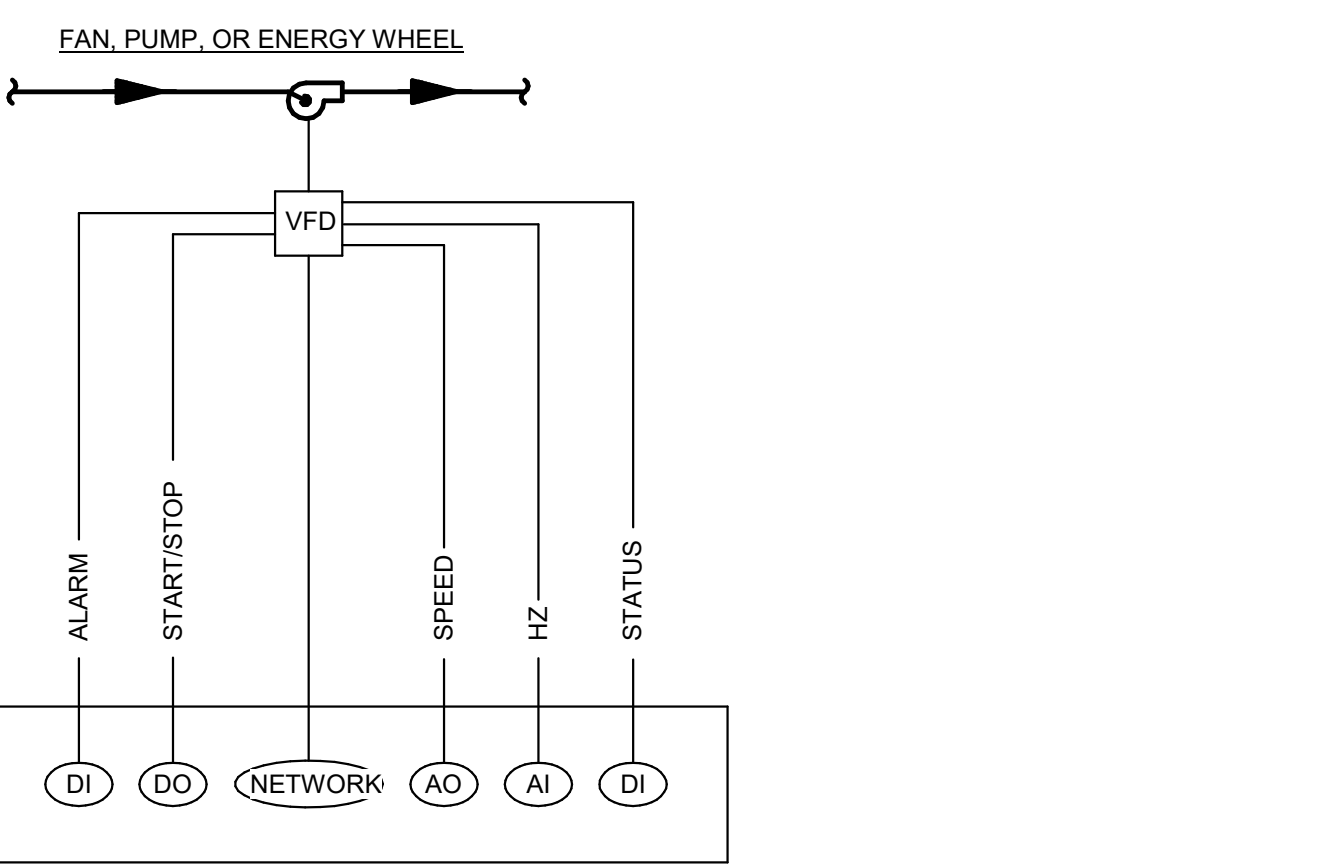

- MONITOR VARIABLE SPEED DRIVES FROM POINTS INDICATED ON CONTROL DIAGRAMS AND THROUGH LAN COMMUNICATIONS PORT ON EACH DRIVE. AS MINIMUM, MONITOR AND/OR REPORT THE FOLLOWING POINTS:
 - FREQUENCY OUTPUT - HZ
 - SPEED - HZ
 - CURRENT - AMPS
 - POWER - KW
 - ENERGY - KWH
 - RUNTIME - HOURS
 - SYSTEM FAULT
 - INPUT SPEED SETPOINT - HZ (REPORTING IN "PERCENT" SPEED IS NOT ACCEPTABLE)
 - GENERATE AN ALARM IF VFD STATUS IS LOST FOR MORE THAN 1 MINUTE, VFD FAULT, DRIVE FAILURE, IS OFF, OR IN HAND.

3 MOTOR WITH VFD (TYPICAL)
NO SCALE

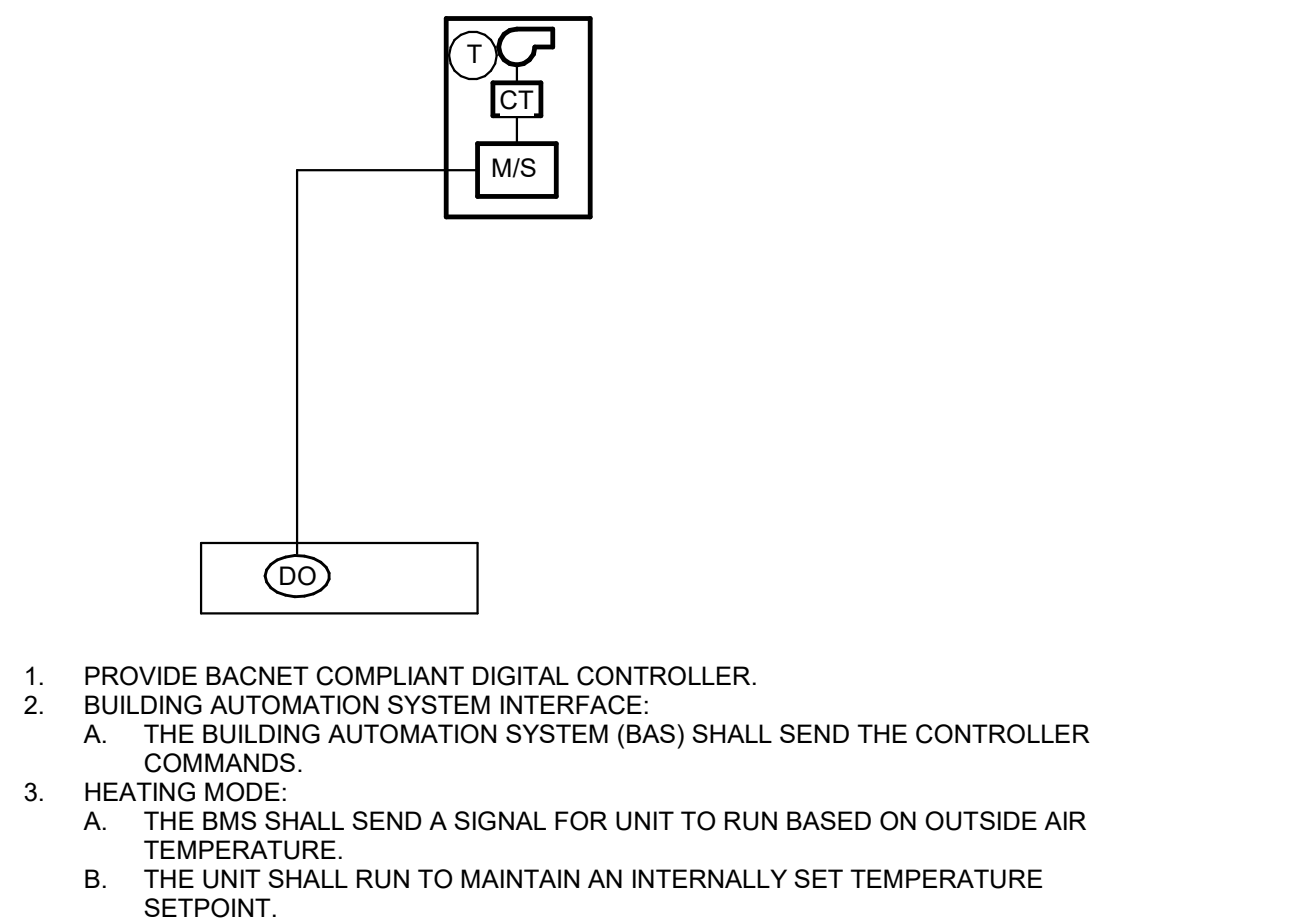

4 UNIT HEATER CONTROL DIAGRAM
NO SCALE

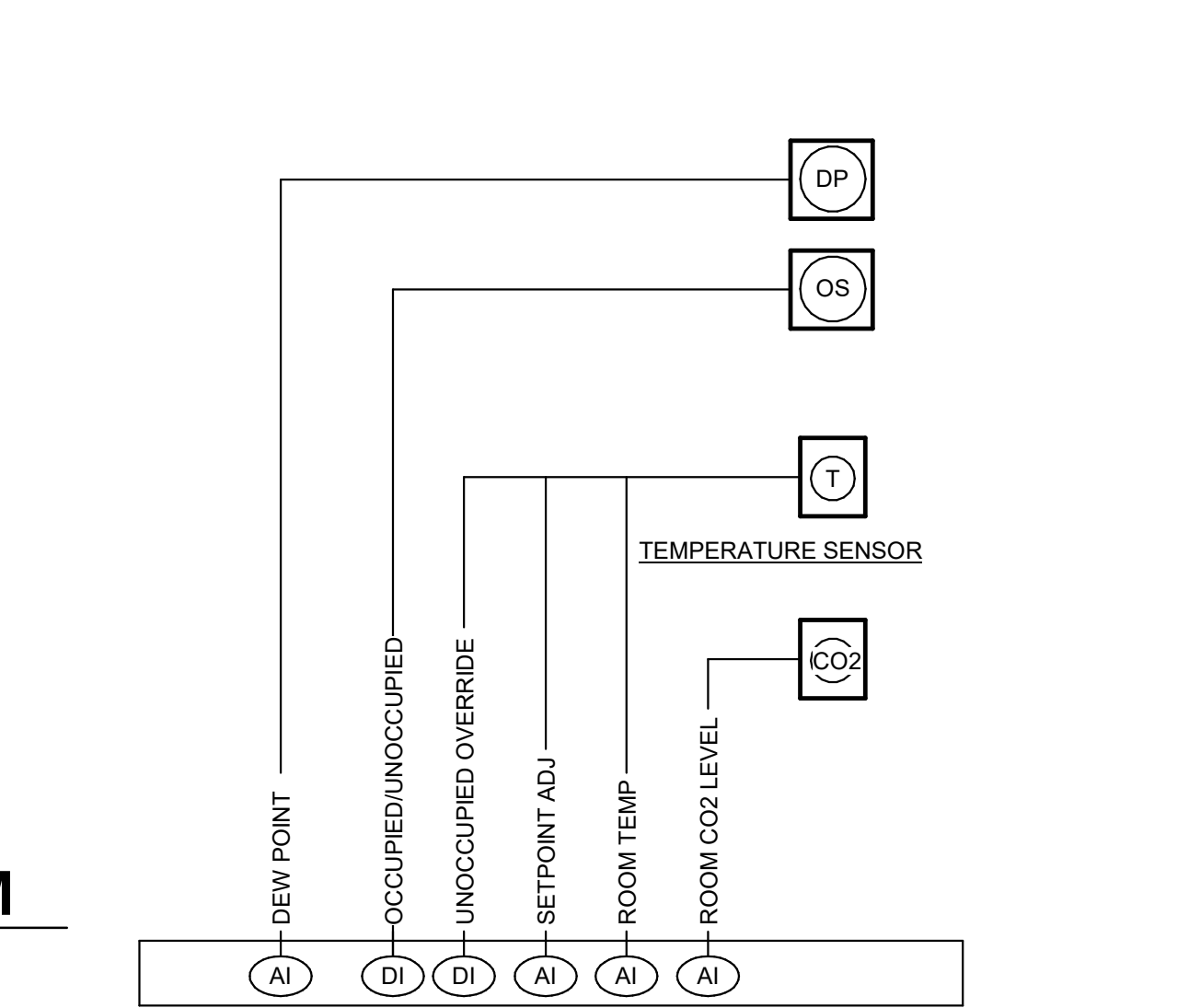

- NOTE:**
- PROVIDE DIGITAL DISPLAY EXCEPT WHERE LOCATED IN LOBBIES AND CORRIDORS.
 - PROVIDE CO2 SENSORS AS SHOWN ON DRAWINGS AND IN ROOMS WITH A MIN OCCUPANCY OF 40 PERSONS PER 1,000 SF.
 - USE OCCUPANCY SENSORS FROM LIGHTING CONTROL SYSTEM FOR OCCUPANCY CONTROL WHEN AVAILABLE.
 - PROVIDE DEWPOINT SENSOR IN SPACES SERVED BY RADIANT OR SENSIBLE COOLING EQUIPMENT.

5 ROOM THERMOSTAT (TYPICAL)
NO SCALE

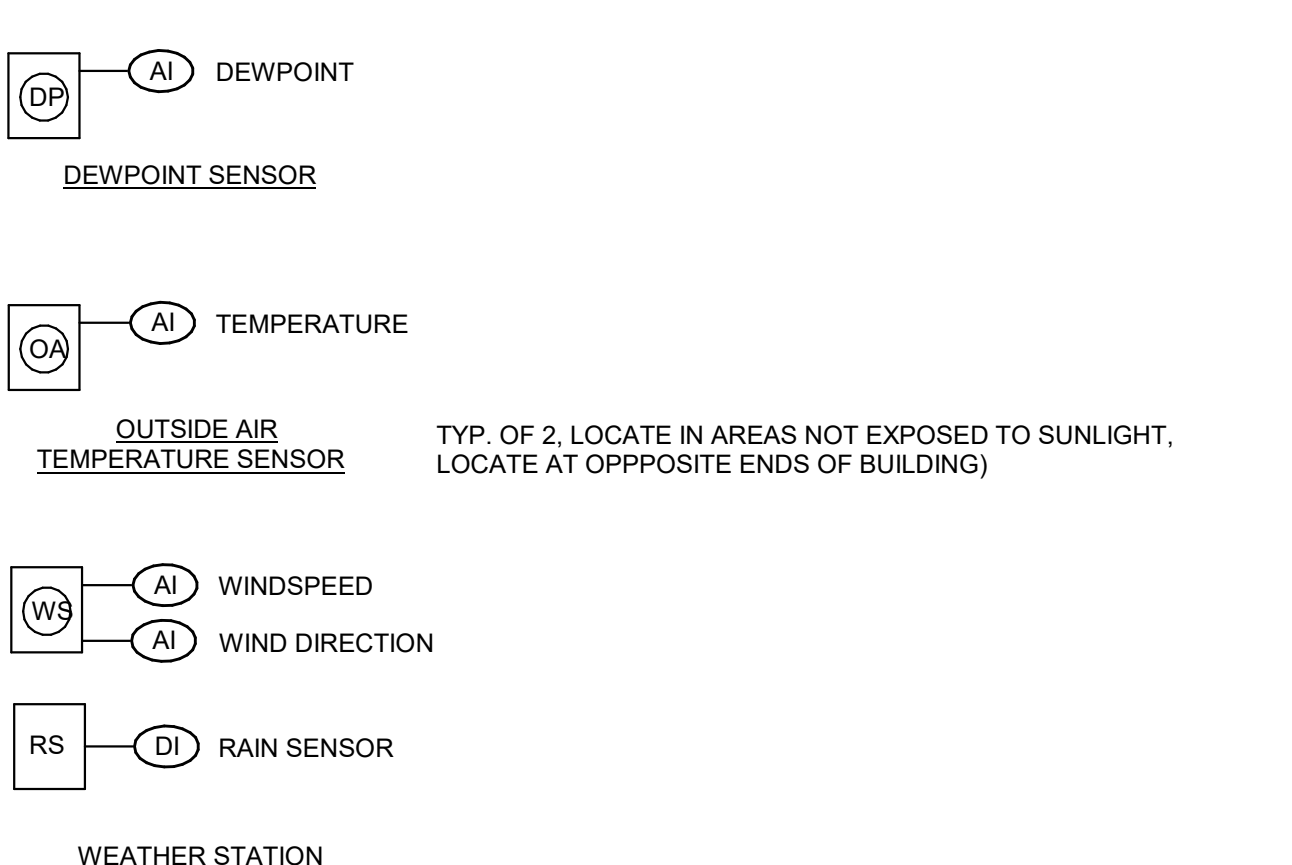

6 MISCELLANEOUS POINTS
NO SCALE

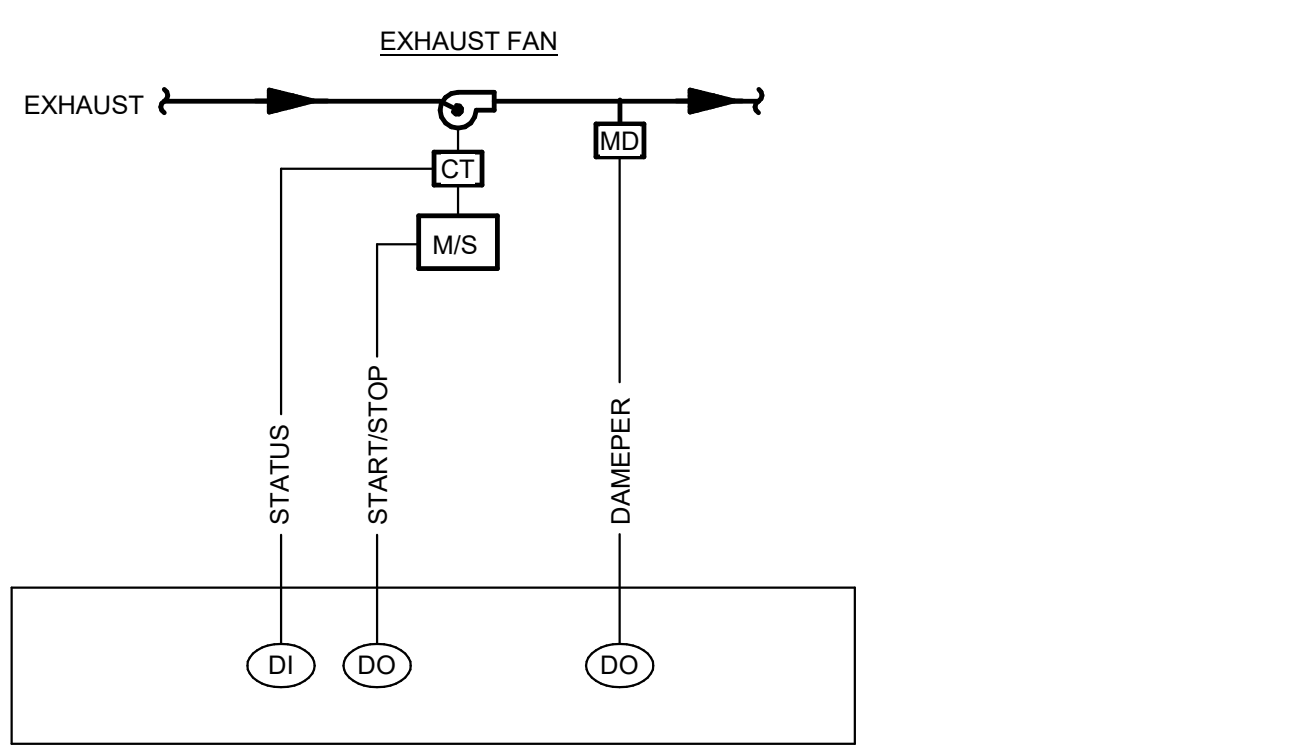

- FAN TO START/STOP BASED ON OCCUPANCY SCHEDULE.
- DAMPER TO OPEN DURING OCCUPIED MODES AND CLOSE DURING UNOCCUPIED MODES.
- GENERATE AN ALARM IF STATUS IS LOST FOR MORE THAN 1 MINUTE, MOTOR FAULT, MOTOR FAILURE, IS OFF, OR IN HAND.

7 EXHAUST FAN CONTROL (TYPICAL)
NO SCALE

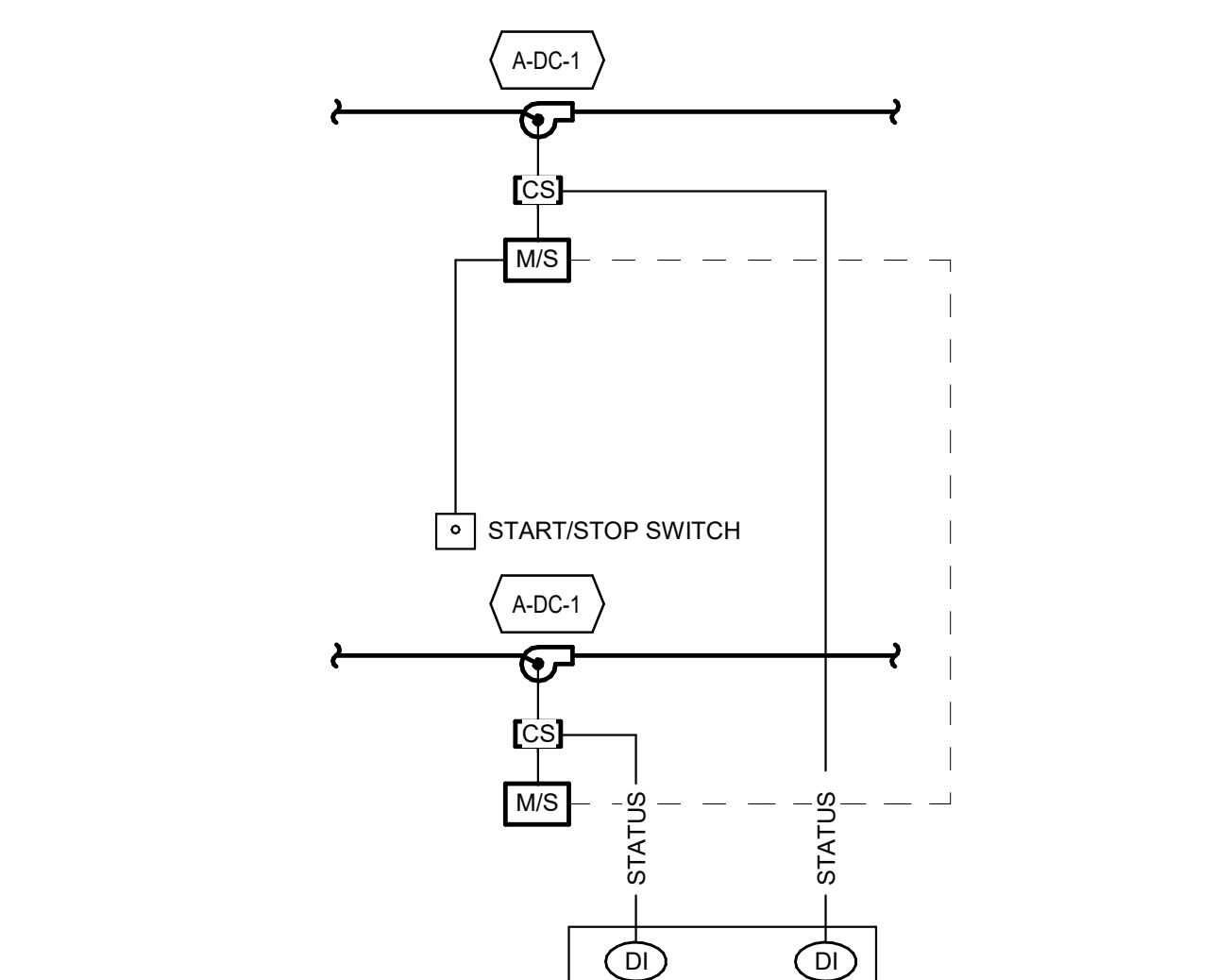

- DUST COLLECTOR TO OPERATE BASED ON PUSH BUTTON IN WOOD SHOP.
- A-EF-2 SHALL BE INTERLOCKED AND SHALL TURN OFF WHEN THE DUST COLLECTOR IS OPERATING.

8 DUST COLLECTOR CONTROL DIAGRAM
NO SCALE

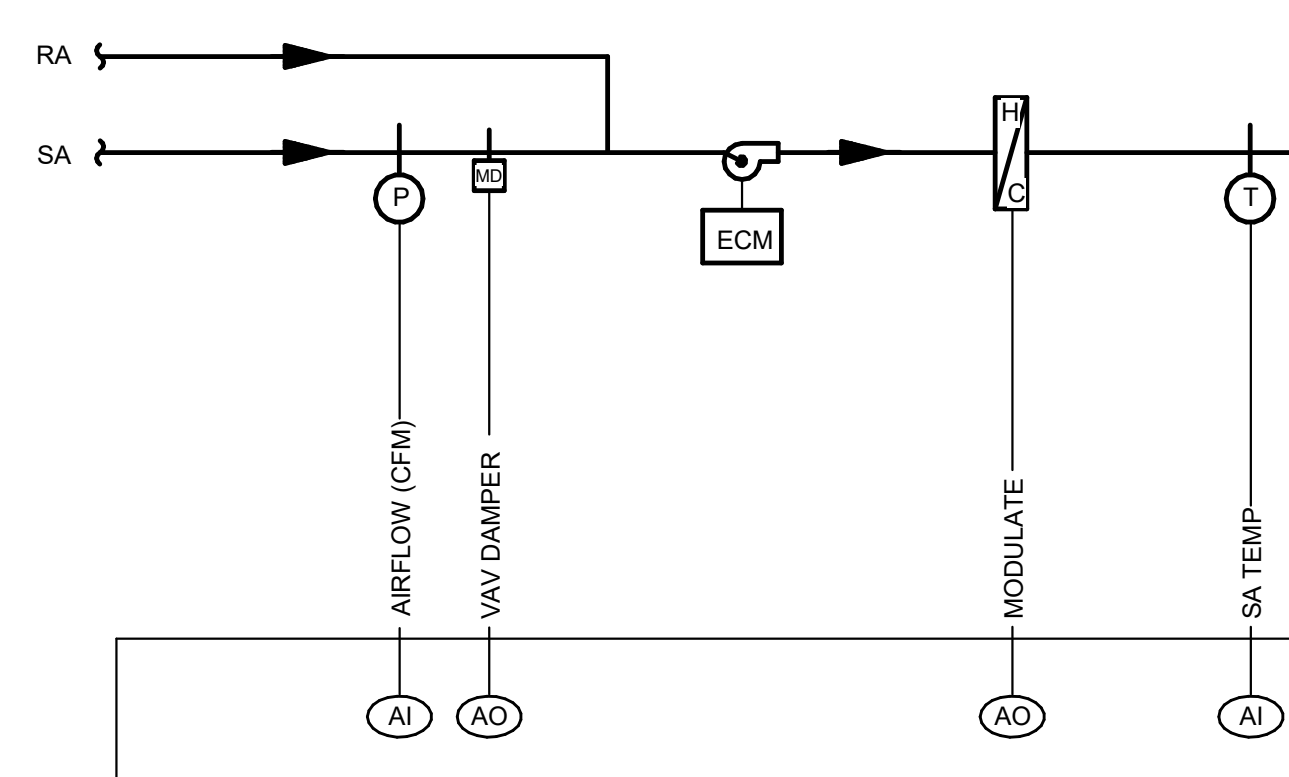

- FAN POWERED TERMINAL UNIT CONTROLLER RECEIVES SIGNAL FROM BUILDING CONTROLLER WHICH INITIATES OCCUPIED OR UNOCCUPIED MODE. DURING UNOCCUPIED MODE SPACE TEMPERATURE RESET TO UNOCCUPIED SETPOINTS AND DURING COOLING MODE SPACE TEMPERATURE RESET TO OCCUPIED SETPOINTS. WHEN ENTERING OCCUPIED MODE, USE AN OPTIMAL START ALGORITHM FOR WARM-UP OR COOL-DOWN, MINIMIZE THE WARM-UP OR COOL-DOWN PERIOD WHILE STILL ACHIEVING COMFORT CONDITIONS BY THE START OF SCHEDULED OCCUPIED PERIOD.
- UNOCCUPIED MODE:
 - CLOSE DAMPER, SHUT OFF FAN AND CLOSE HOT WATER HEATING VALVE. IGNORE ANY SIGNALS FROM SPACE OCCUPANCY OR CARBON DIOXIDE SENSORS.
 - IF SPACE TEMPERATURE IS GREATER THAN UNOCCUPIED COOLING SETPOINT, AND IF CENTRAL AIR HANDLING UNIT SUPPLY FAN IS RUNNING, START FAN AND MODULATE DAMPER BETWEEN MINIMUM AND MAXIMUM COOLING AIRFLOW SETPOINTS TO MAINTAIN SPACE TEMPERATURE AT UNOCCUPIED COOLING SETPOINT.
 - IF SPACE TEMPERATURE IS LESS THAN UNOCCUPIED HEATING SETPOINT, MODULATE HOT WATER COIL VALVE SUBJECT TO A MAXIMUM DISCHARGE AIR TEMPERATURE OF 95 DEGREES F (ADJ.) TO MAINTAIN SPACE TEMPERATURE AT UNOCCUPIED HEATING SETPOINT.
- OCCUPIED MODE:
 - START FAN, MODULATE DAMPER TO MAINTAIN MINIMUM AIRFLOW SETPOINT, AND CLOSE HOT WATER HEATING VALVE.
 - IF SPACE TEMPERATURE IS GREATER THAN OCCUPIED COOLING SETPOINT, MODULATE DAMPER BETWEEN MINIMUM AND MAXIMUM COOLING AIRFLOW SETPOINTS TO MAINTAIN SPACE TEMPERATURE AT OCCUPIED COOLING SETPOINT.
 - IF SPACE TEMPERATURE IS LESS THAN OCCUPIED HEATING SETPOINT, MODULATE HOT WATER COIL VALVE SUBJECT TO A MAXIMUM DISCHARGE AIR TEMPERATURE OF 95 DEGREES F (ADJ.) TO MAINTAIN SPACE TEMPERATURE AT OCCUPIED HEATING SETPOINT.
 - FOR ZONES WITH OCCUPANCY SENSORS, ENTER "STANDBY MODE" IF THE OCCUPANCY SENSOR DOES NOT DETECT OCCUPANCY FOR 15 MINUTES (ADJ.). DURING STANDBY MODE, COOLING SETPOINT RESETS TO 3 DEGREES F (ADJ.) ABOVE NORMAL OCCUPIED COOLING SETPOINT AND HEATING SETPOINT RESETS TO 3 DEGREES F (ADJ.) BELOW NORMAL OCCUPIED HEATING SETPOINT. WHEN OCCUPANCY HAS BEEN DETECTED FOR 5 MINUTES (ADJ.), HEATING AND COOLING SETPOINTS RESET TO NORMAL OCCUPIED TEMPERATURE SETPOINTS.
 - IF SPACE CO2 CONCENTRATION IS GREATER THAN 900 PPM (ADJ.) MODULATE DAMPER BETWEEN MINIMUM AND MAXIMUM COOLING AIRFLOW SETPOINTS TO MAINTAIN CONCENTRATION AT SETPOINT.
- WARM-UP MODE: FAN POWERED TERMINAL UNIT RECEIVES GLOBAL SIGNAL FROM BUILDING CONTROLLER TO INITIATE WARM-UP MODE. DURING WARM-UP MODE CLOSE DAMPER, START FAN AND MODULATE HOT WATER VALVE SUBJECT TO A MAXIMUM DISCHARGE AIR TEMPERATURE OF 95 DEGREES F (ADJ.) TO MAINTAIN SPACE TEMPERATURE AT OCCUPIED HEATING SETPOINT.

9 SERIES FAN-POWERED TERMINAL UNIT WITH ELECTRIC REHEAT
NO SCALE

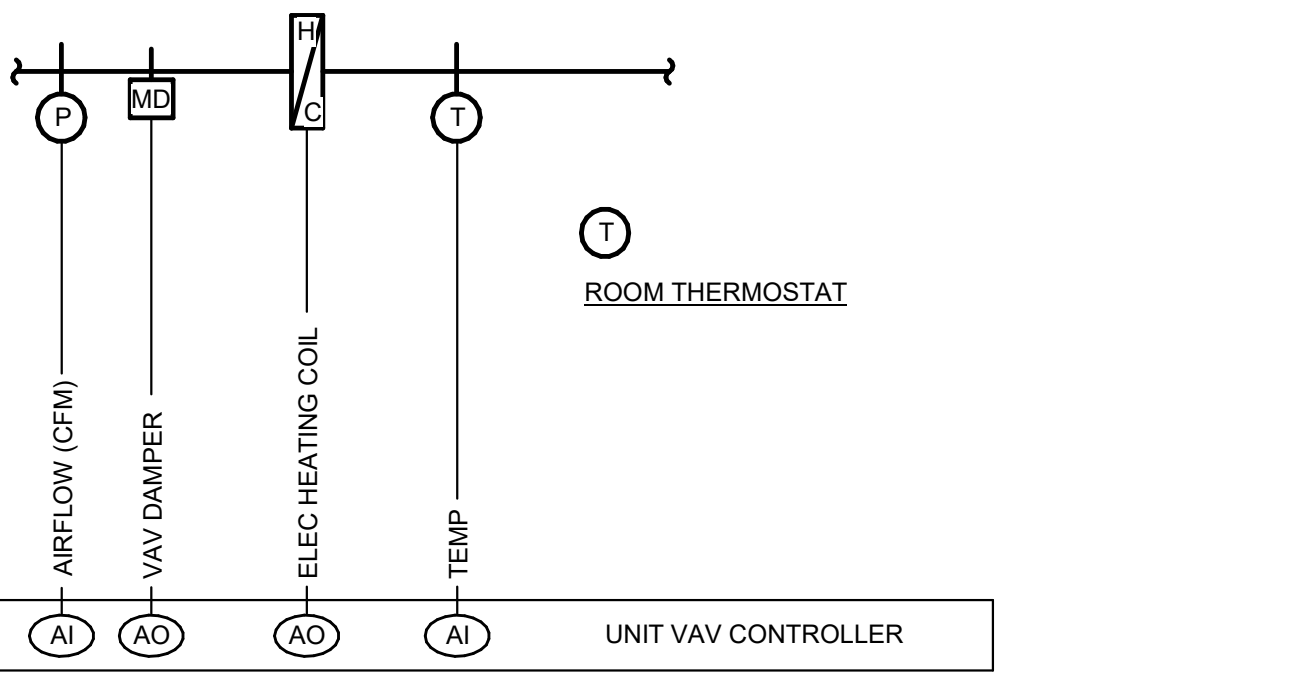

- TERMINAL UNIT CONTROLLER RECEIVES SIGNAL FROM BUILDING CONTROLLER WHICH INITIATES OCCUPIED OR UNOCCUPIED MODE. DURING UNOCCUPIED MODE SPACE TEMPERATURE RESET TO UNOCCUPIED SETPOINTS AND DURING COOLING MODE SPACE TEMPERATURE RESETS TO OCCUPIED SETPOINTS. WHEN ENTERING OCCUPIED MODE, USE AN OPTIMAL START ALGORITHM FOR WARM-UP OR COOL-DOWN, MINIMIZE THE WARM-UP OR COOL-DOWN PERIOD WHILE STILL ACHIEVING COMFORT CONDITIONS BY THE START OF SCHEDULED OCCUPIED PERIOD.
- UNOCCUPIED MODE:
 - TERMINAL UNIT DAMPER CLOSED. IGNORE ANY SIGNALS FROM SPACE OCCUPANCY OR CARBON DIOXIDE SENSORS.
 - IF SPACE TEMPERATURE IS GREATER THAN UNOCCUPIED COOLING SETPOINT, AND IF CENTRAL AIR HANDLING UNIT SUPPLY FAN IS RUNNING, MODULATE DAMPER BETWEEN MINIMUM AND MAXIMUM COOLING AIRFLOW SETPOINTS TO MAINTAIN SPACE TEMPERATURE AT UNOCCUPIED COOLING SETPOINT.
- OCCUPIED MODE:
 - MODULATE DAMPER TO MAINTAIN MINIMUM AIRFLOW SETPOINT.
 - IF SPACE TEMPERATURE IS GREATER THAN OCCUPIED COOLING SETPOINT, MODULATE DAMPER BETWEEN MINIMUM AND MAXIMUM AIRFLOW SETPOINTS TO MAINTAIN SPACE TEMPERATURE AT OCCUPIED COOLING SETPOINT.
 - FOR ZONES WITH OCCUPANCY SENSORS, ENTER "STANDBY MODE" IF THE OCCUPANCY SENSOR DOES NOT DETECT OCCUPANCY FOR 15 MINUTES (ADJ.). DURING STANDBY MODE, COOLING SETPOINT RESETS TO 3 DEGREES F (ADJ.) ABOVE NORMAL OCCUPIED COOLING SETPOINT AND HEATING SETPOINT RESETS TO 3 DEGREES F (ADJ.) BELOW NORMAL OCCUPIED HEATING SETPOINT. WHEN OCCUPANCY HAS BEEN DETECTED FOR 5 MINUTES (ADJ.), HEATING AND COOLING SETPOINTS RESET TO NORMAL OCCUPIED TEMPERATURE SETPOINTS.
 - IF SPACE CO2 CONCENTRATION IS GREATER THAN 900 PPM (ADJ.), MODULATE DAMPER BETWEEN MINIMUM AND MAXIMUM COOLING AIRFLOW SETPOINTS TO MAINTAIN CONCENTRATION AT SETPOINT.
- WARM-UP MODE: TERMINAL UNIT RECEIVES GLOBAL SIGNAL FROM BUILDING CONTROLLER TO INITIATE WARM-UP MODE. DURING WARM-UP MODE MODULATE DAMPER BETWEEN MINIMUM AND MAXIMUM AIRFLOW SETPOINTS TO MAINTAIN SPACE TEMPERATURE AT OCCUPIED HEATING SETPOINT.

10 VAV BOX CONTROL DIAGRAM
NO SCALE

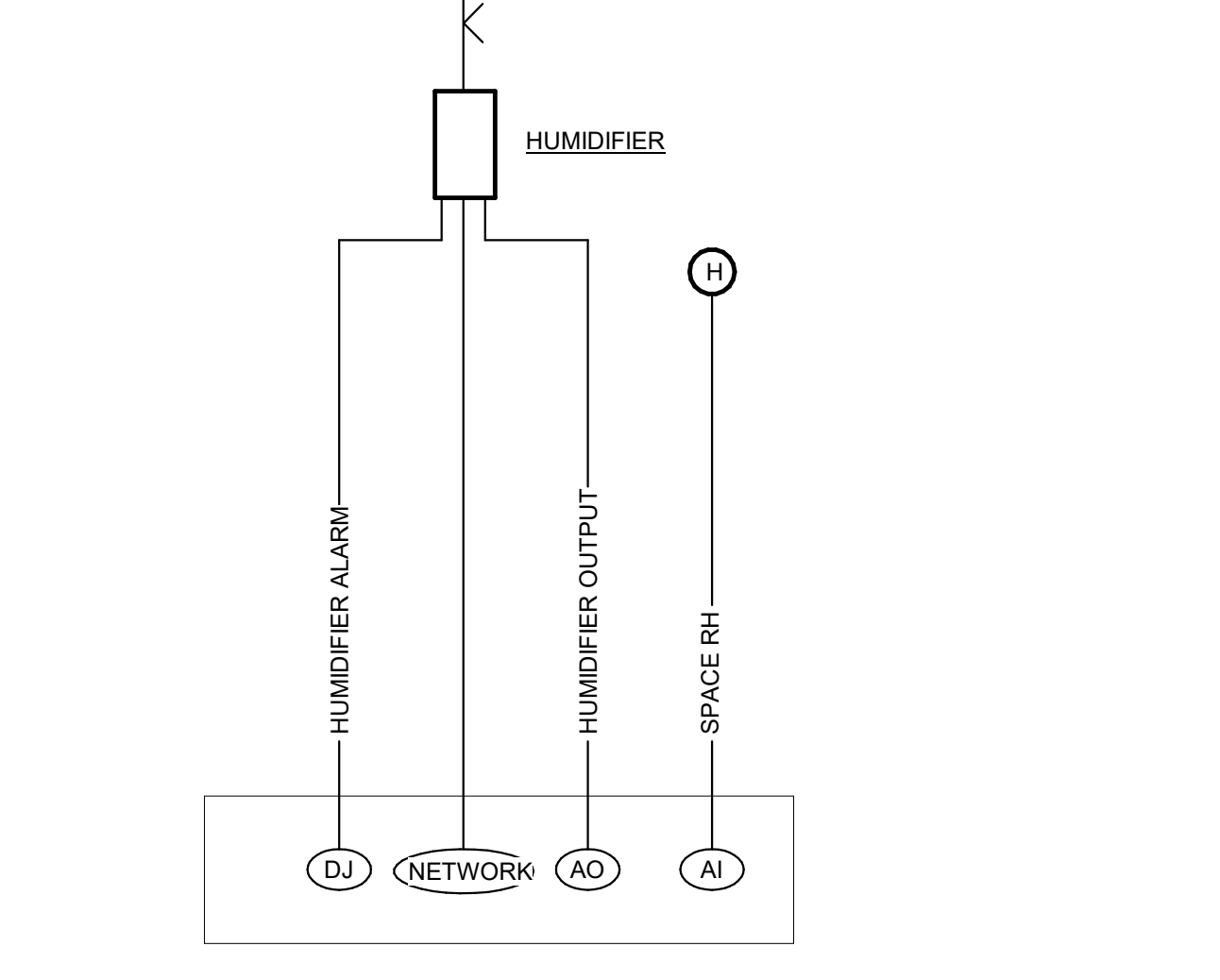

- HUMIDIFICATION CONTROL. MODULATE HUMIDIFIER OUTPUT TO MAINTAIN SPACE RELATIVE HUMIDITY SETPOINT (ADJ.)

11 HUMIDIFIER
NO SCALE

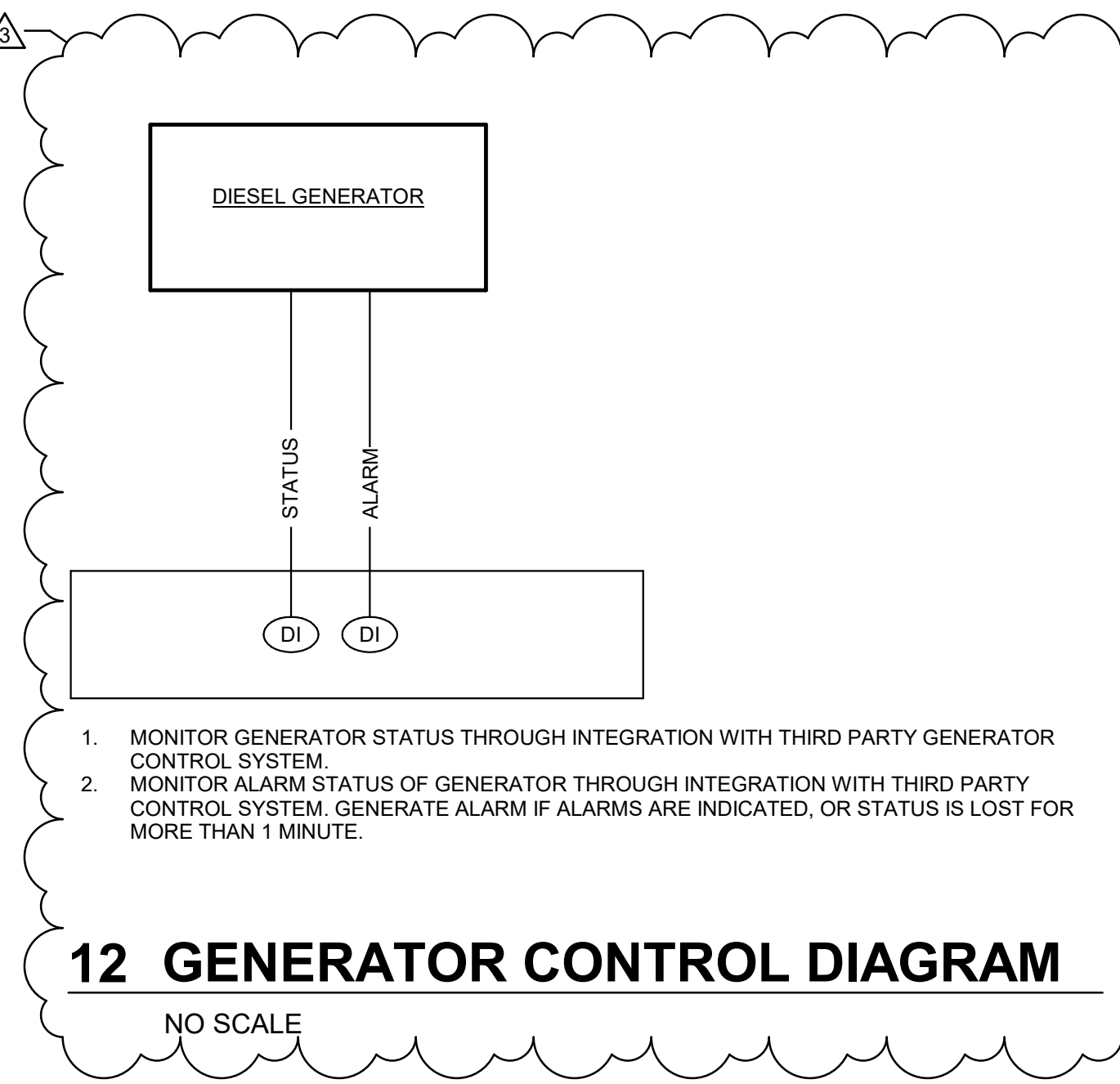

- MONITOR GENERATOR STATUS THROUGH INTEGRATION WITH THIRD PARTY GENERATOR CONTROL SYSTEM.
- MONITOR ALARM STATUS OF GENERATOR THROUGH INTEGRATION WITH THIRD PARTY CONTROL SYSTEM. GENERATE ALARM IF ALARMS ARE INDICATED, OR STATUS IS LOST FOR MORE THAN 1 MINUTE.

12 GENERATOR CONTROL DIAGRAM
NO SCALE

TACTICAL TRAINING DESIGN

Tactical Design North
231 E. Buffalo St #502, Milwaukee, WI 53202

LOCAL ARCHITECT

Jacobs Wyper Architects
1232 Chancellor St, Philadelphia, PA 19107

STRUCTURAL ENGINEER

Skidmore, Owings & Merrill LLP
250 Greenwich St, New York, NY 10007

ELECTRICAL, PLUMBING, FIRE PROTECTION, FIRE ALARM ENGINEER

A & J Consulting Engineering Services, P.C.
164 Brighton Rd, Clifton, NJ 07012

MECHANICAL AVIATION ENGINEER

Interface Engineering, Inc.
2000 M Street NW, Suite 270, Washington, DC 20036

ACOUSTICAL ENGINEER

Cerami
1001 Ave of the Americas, 4th Floor, New York, NY 10018

CODE CONSULTING

CCI
215 W 40th St, 10th Floor, New York, NY 10018

CIVIL ENGINEER

Langan
1818 Market St #3300, Philadelphia, PA 19103

VERTICAL TRANSPORT

Michael Blades & Associates Ltd.
5409 Rapiant Ct, Lothian, MD 20711

SIGNAGE CONSULTANT

Patricia Hord Graphik Design
119 S. St. Asaph St, Alexandria, VA 22314

LANDSCAPE

Lee and Associates, Inc.
6381 Street NW, Washington, DC 20001

LIGHTING

MCLA
1000 Patomac St NW, Suite 121, Washington, DC 20007

FOOD SERVICE

Hopkins Foodservice Specialists, Inc.
7906 MacArthur Blvd, Suite 100, Cabin John, MD 20818

COST ESTIMATING

AECOM
1700 Market St, Suite 1600, Philadelphia, PA 19103

KEYPLAN

NO.	DATE	DESCRIPTION	NO.	DATE	DESCRIPTION
1	19 MAY 2022	ISSUED FOR BID			
2	29 JUN 2023	ADDENDUM 29			

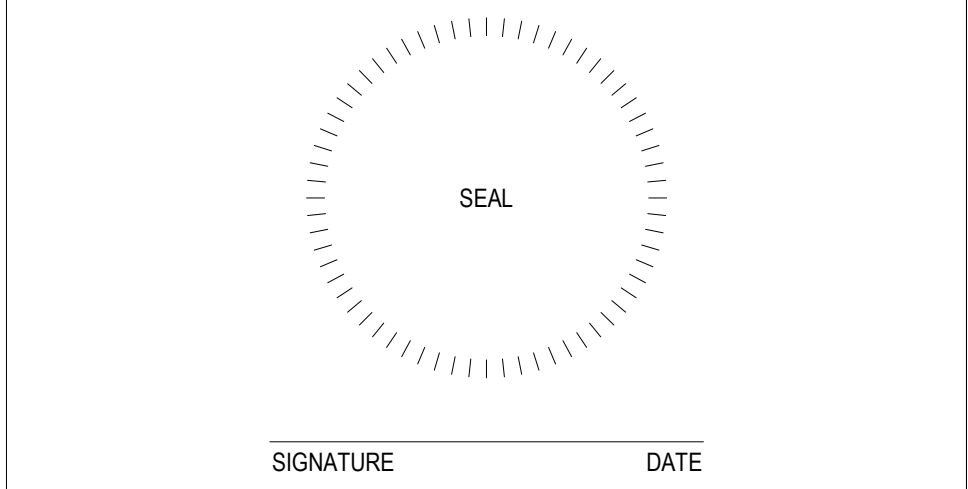

ARCHITECT

SOM
Skidmore, Owings & Merrill LLP
250 Greenwich St, New York, 10007

COMMONWEALTH OF PENNSYLVANIA
DEPARTMENT OF GENERAL SERVICES
HARRISBURG, PENNSYLVANIA

D.G.S. PROJECT No. **C-0211-0005 PHASE 5**

Pennsylvania State Police Academy
Core Buildings, BESO & Sitework
PENNSYLVANIA STATE POLICE
HERSHEY, DAUPHIN COUNTY, PA

CONTRACTOR SHALL FIELD VERIFY ALL DIMENSIONS. VARIANCE FROM CONTRACT DOCUMENTS NOT PERMITTED WITHOUT PROFESSIONAL & BUREAU OF CONSTRUCTION APPROVAL.

VERIFY SCALE

BAR IS ONE (1) INCH LONG ON ORIGINAL DRAWING: 1

IF BAR IS NOT ONE (1) INCH LONG, ADJUST SCALE ACCORDINGLY

SHEET No. **BSO-M-800**

DRAWN BY	CHECKED BY	DATE	SCALE
Author	Checker		AS NOTED

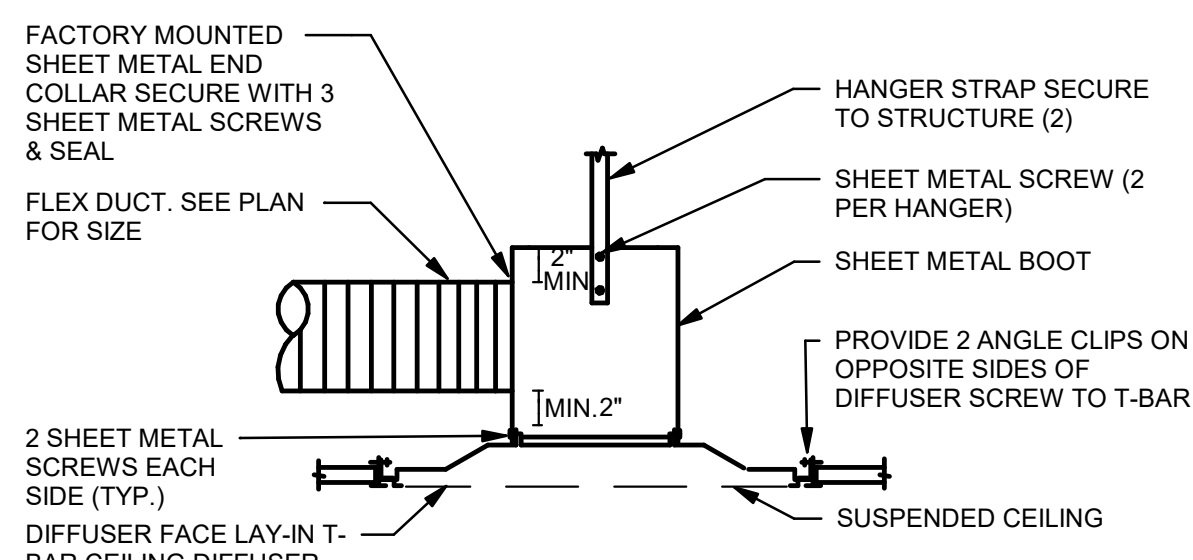

NOTES:
 A. USE THIS DETAIL WHERE 1.5 x RADIUS ON FLEXIBLE DUCT IS NOT POSSIBLE.
 B. SIMILAR FOR GYP BOARD CEILING.

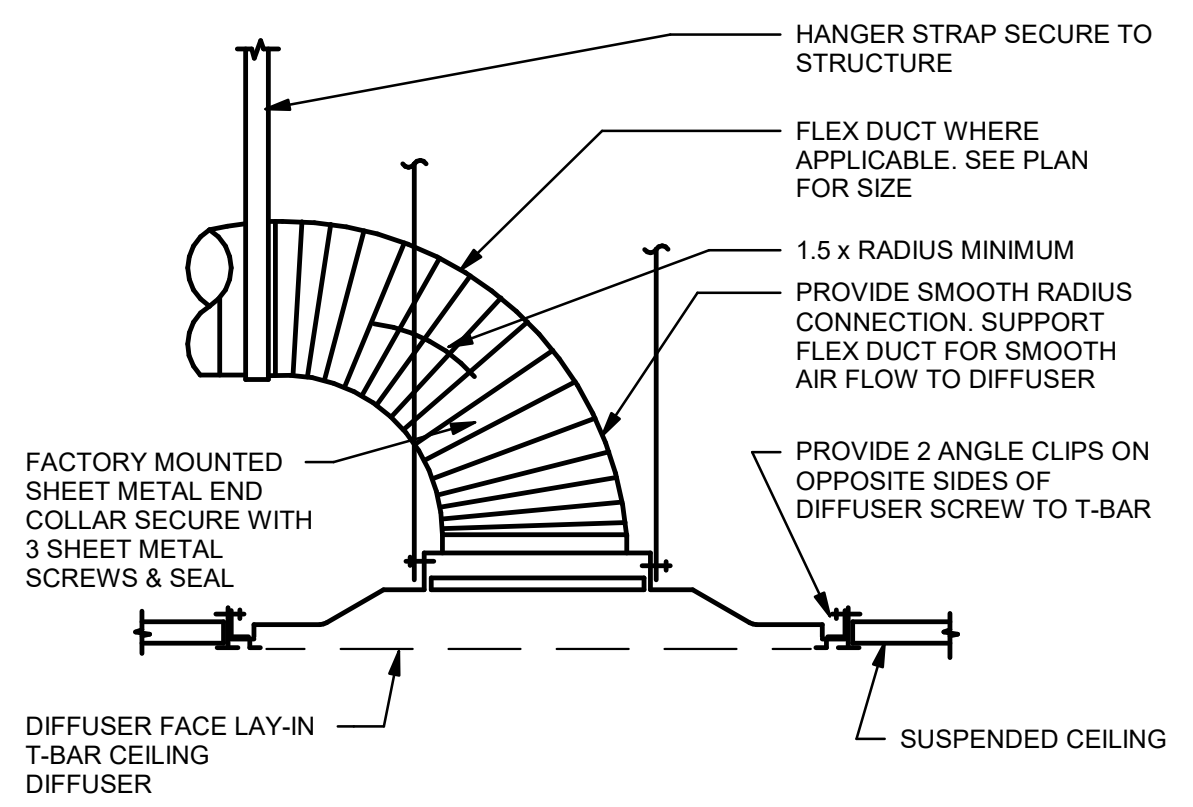

NOTES:
 A. USE MOUNTING DETAIL WHERE SPACE PERMITS. WHERE SPACE DOES NOT PERMIT FOLLOW DETAIL ABOVE.
 B. SIMILAR FOR GYP BOARD, SPLINE CEILING.

1 CEILING DIFFUSER CONNECTION DETAIL
 NO SCALE

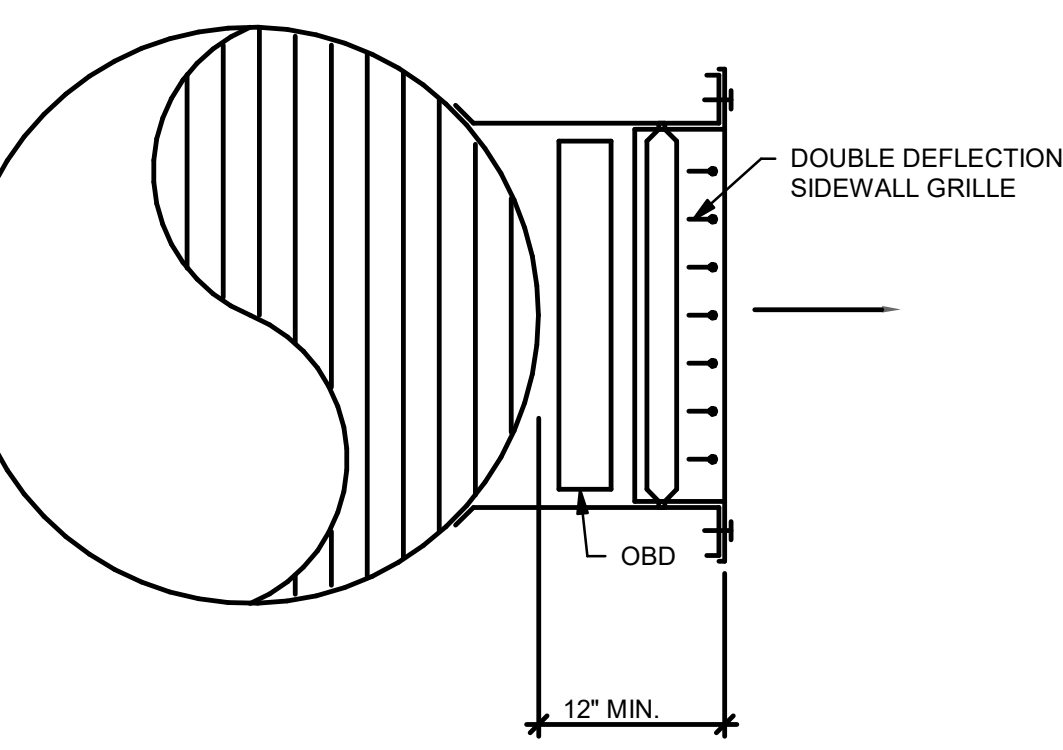

2 DUCT MOUNTED DIFFUSER CONNECTION DETAIL
 NO SCALE

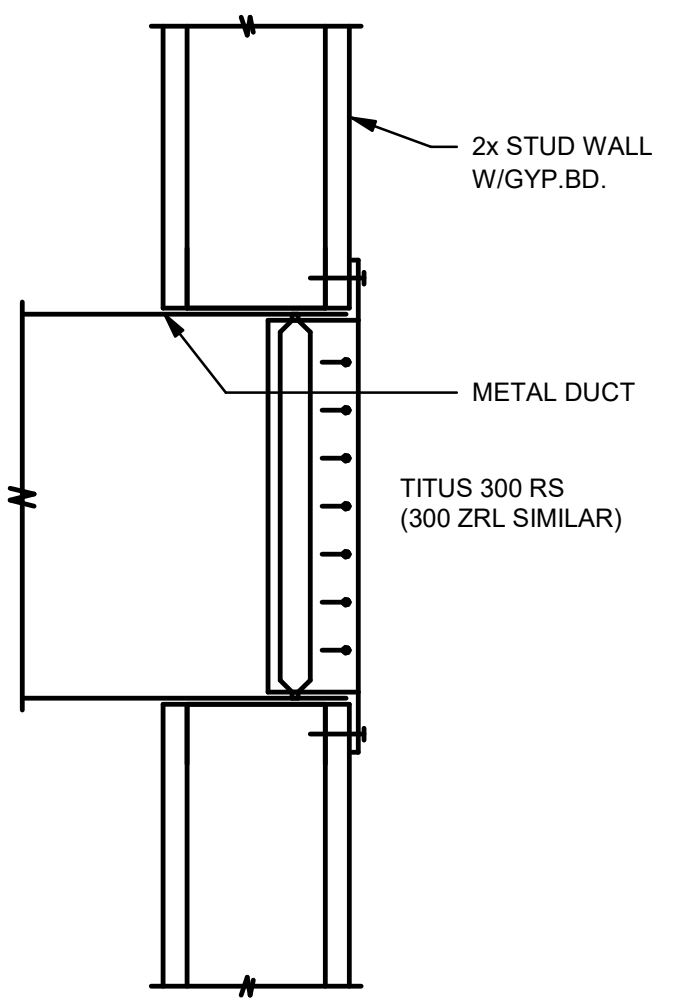

3 SIDEWALL DIFFUSER CONNECTION DETAIL
 NO SCALE

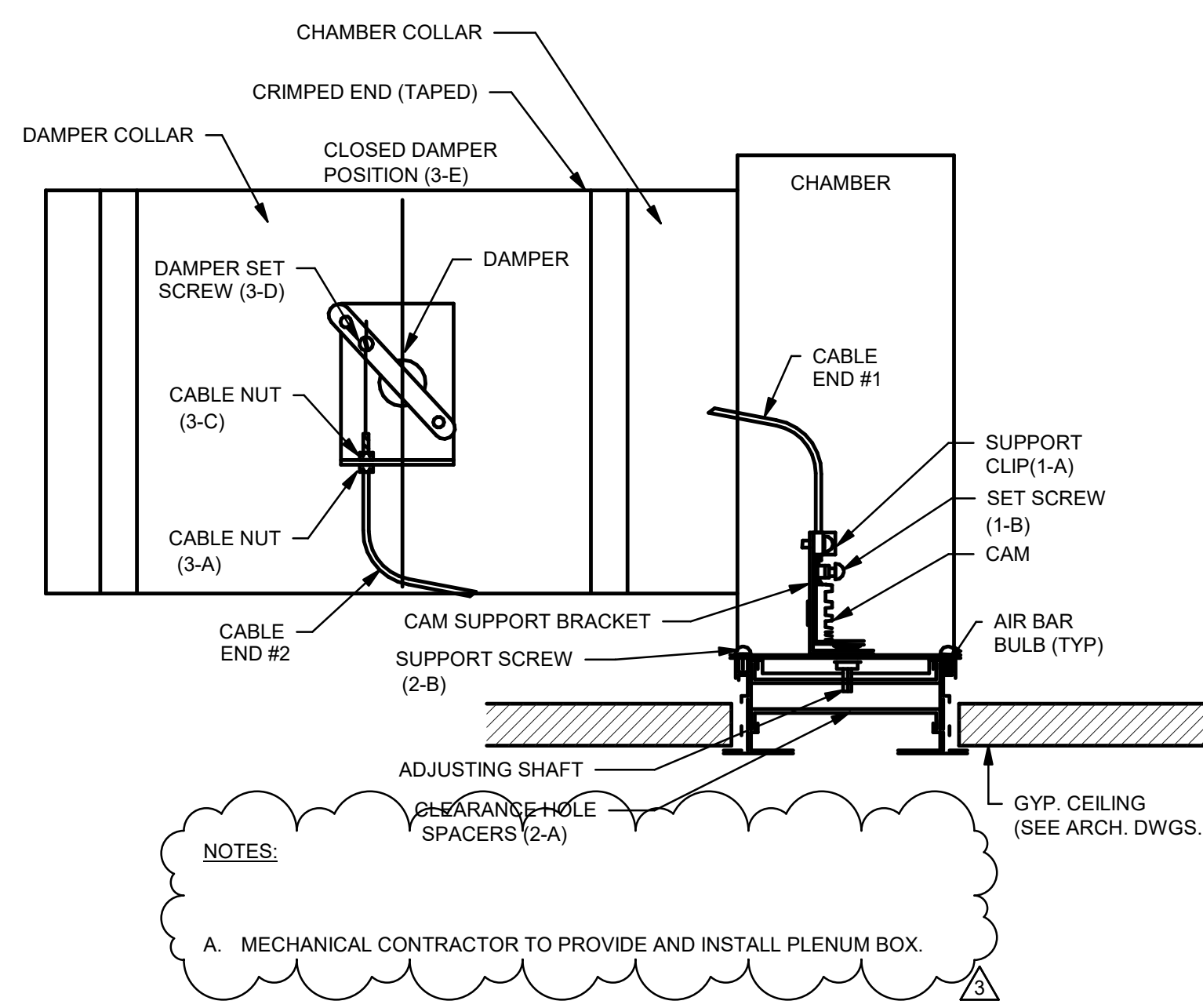

4 SLOT WITH INTEGRAL VOLUME DAMPER
 NO SCALE

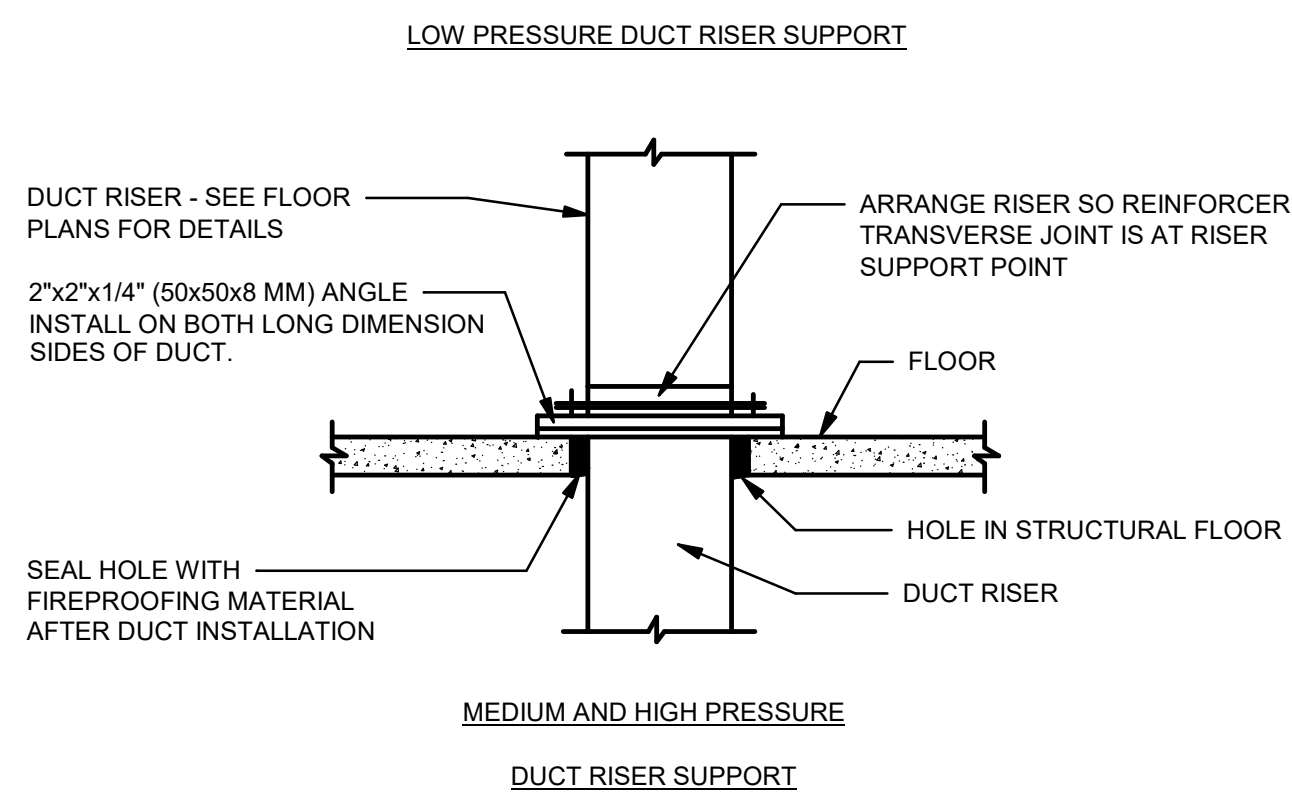
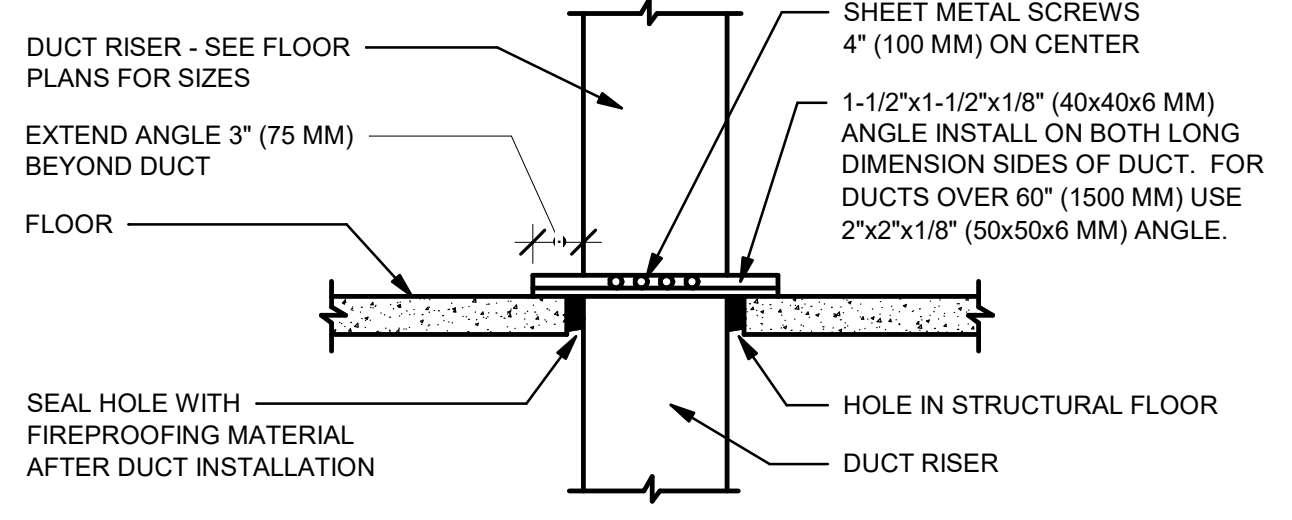

NOTE:
 1. ALL DUCT WORK RISERS WHICH ARE RUN EXPOSED, SUCH AS THRU ATTIC FLOORS AND FAN ROOM FLOORS SHALL BE PROVIDED WITH A 3" (75 MM) HIGH CONCRETE CURB AROUND OPENING FOR DUCT.
DESIGNER'S NOTE:
 1. INDICATE ON DRAWING WHICH DUCTS ARE LOW PRESSURE (2" (50 MM) WG OR LESS) AND WHICH ARE MEDIUM AND HIGH PRESSURE (2" (50 MM) WG TO 10" (250 MM) WG).

5 DUCT RISER SUPPORT
 NO SCALE

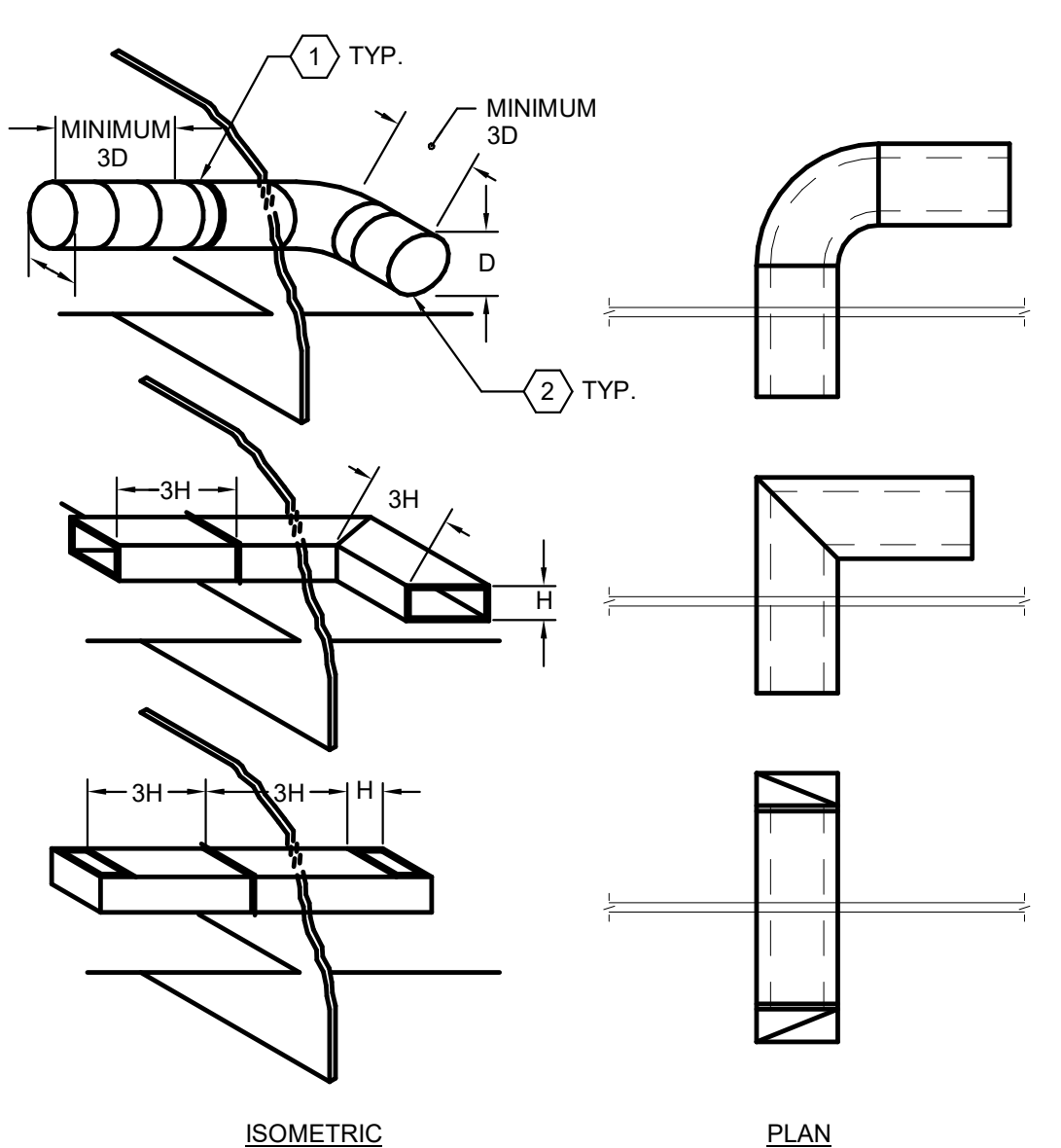

NOTES:
 1. HOLD GYPSUM BOARD BACK 1/4" AND CAULK WALL AIRTIGHT AT INTERSECTION WITH DUCTWORK.
 2. INTERNALLY LINE ALL DUCTWORK WITH 1" THICK ACOUSTICAL LINING.

6 ACOUSTIC AIR TRANSFER DUCT DETAILS
 NO SCALE

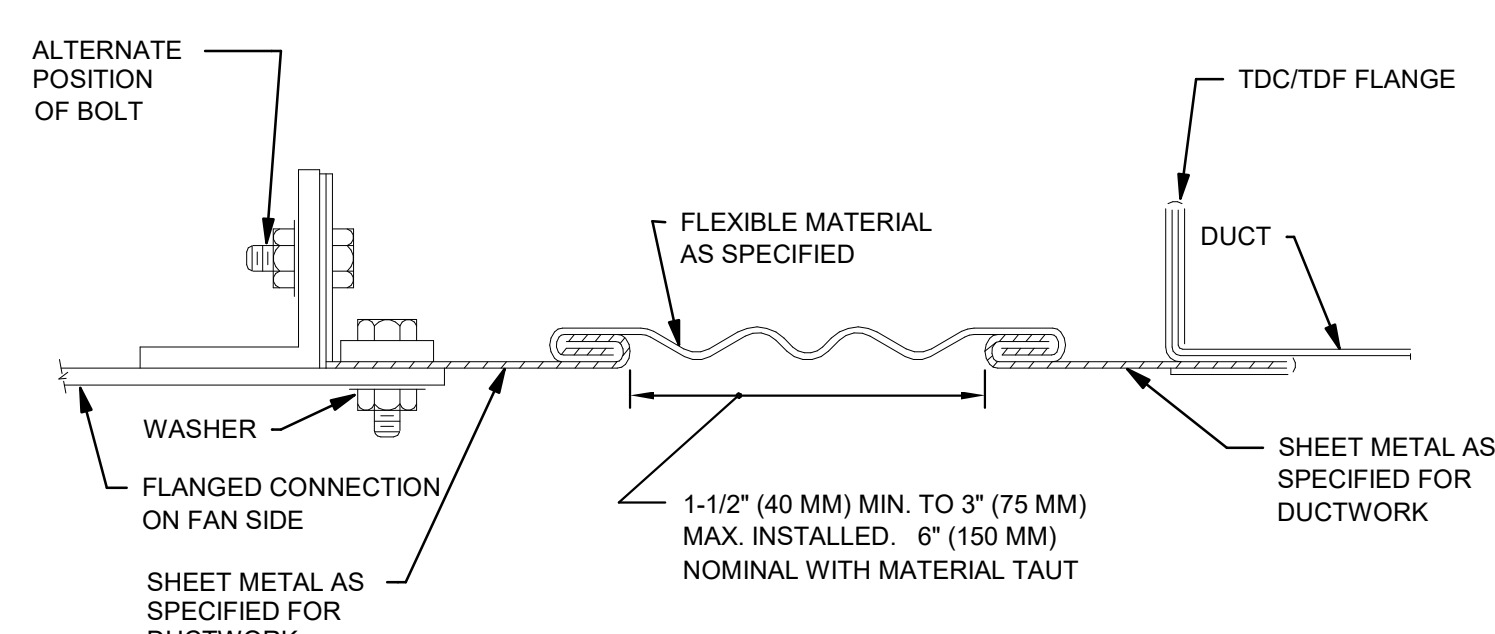

RECTANGULAR FLEXIBLE CONNECTION

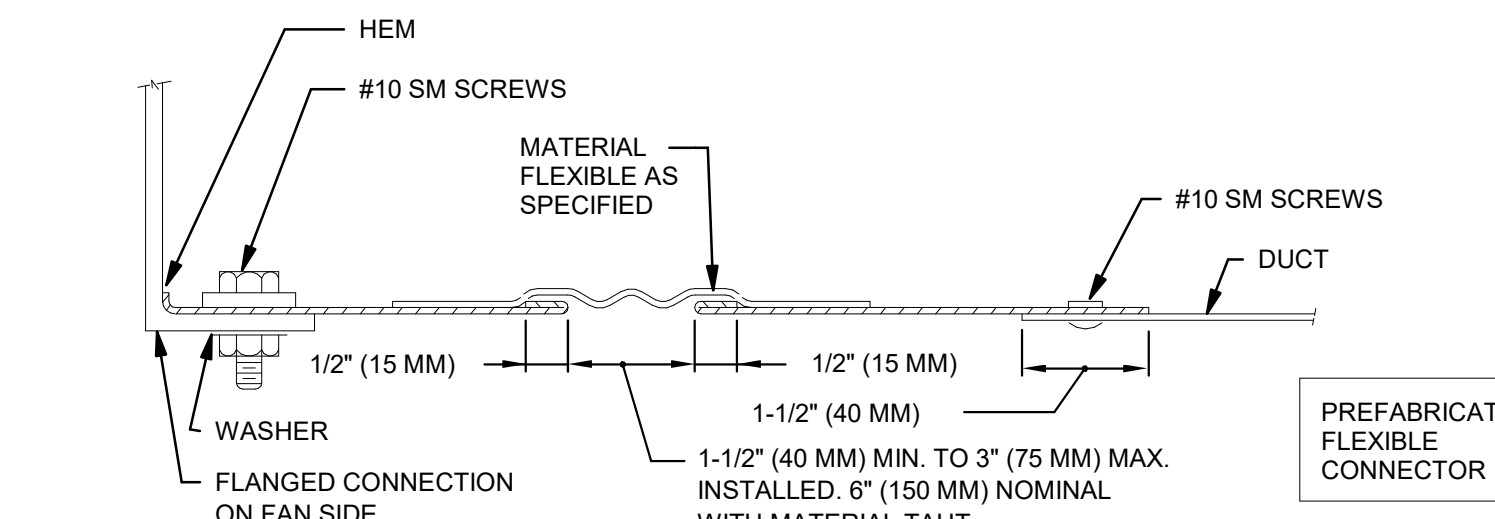

ROUND FLEXIBLE CONNECTION

7 DUCT SUPPORT DETAIL
 NO SCALE

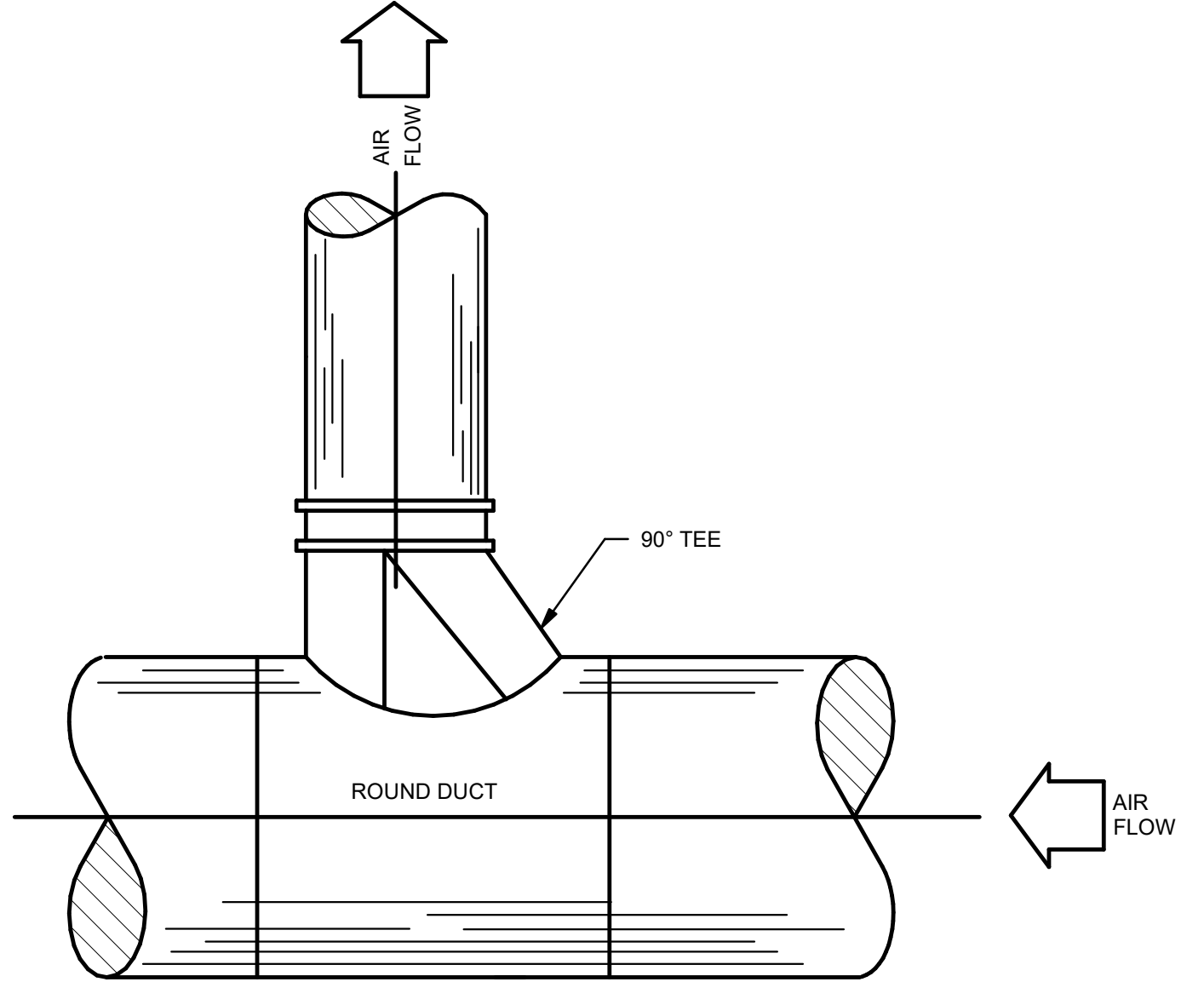

8 LOW LOSS FITTING ROUND TO ROUND
 NO SCALE

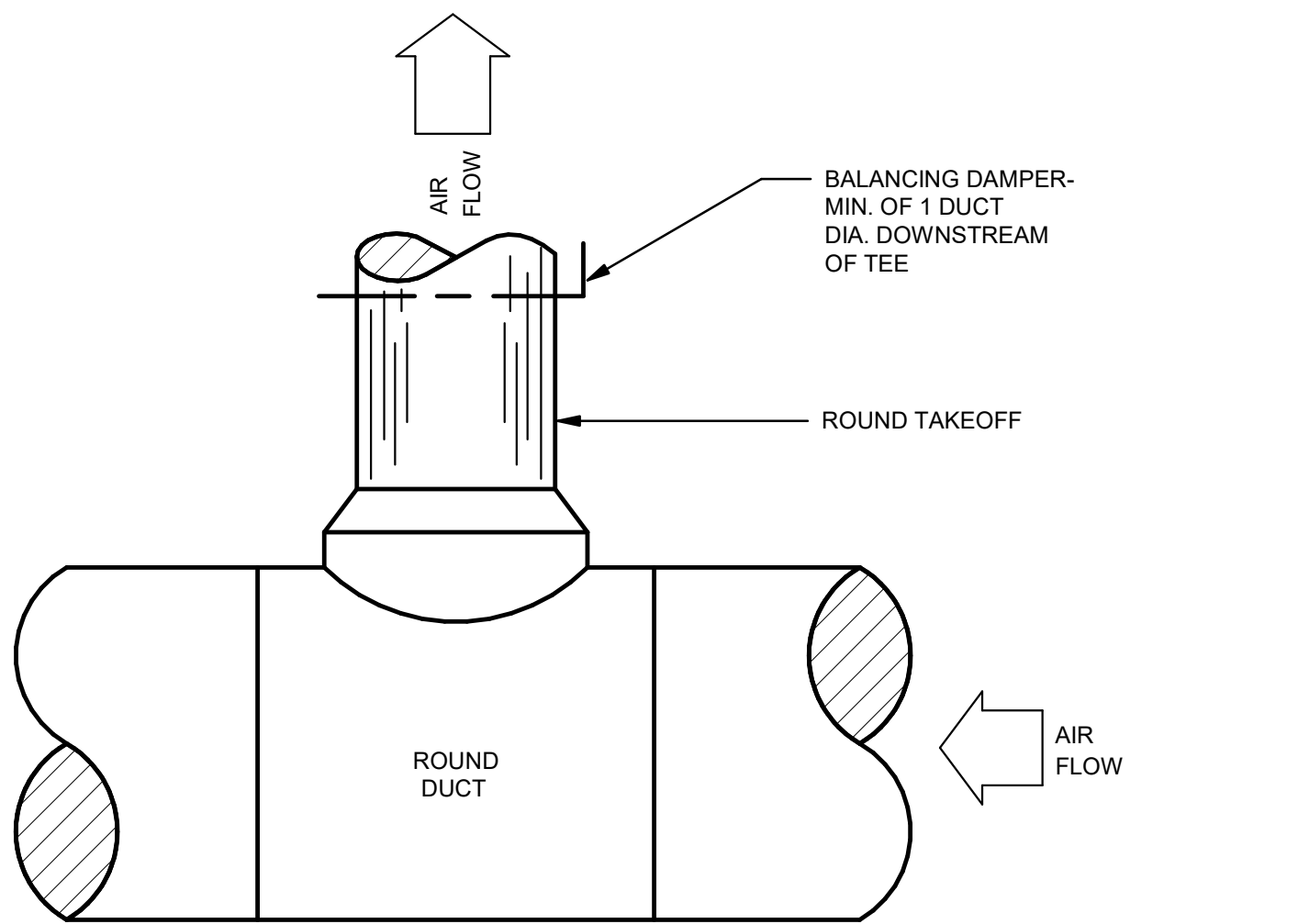

NOTE:
 A. SHALL BE USED ON ALL DUCTS UPSTREAM OF TERMINAL UNITS.

9 MEDIUM PRESSURE DUCT TAP - CONICAL TEE
 NO SCALE

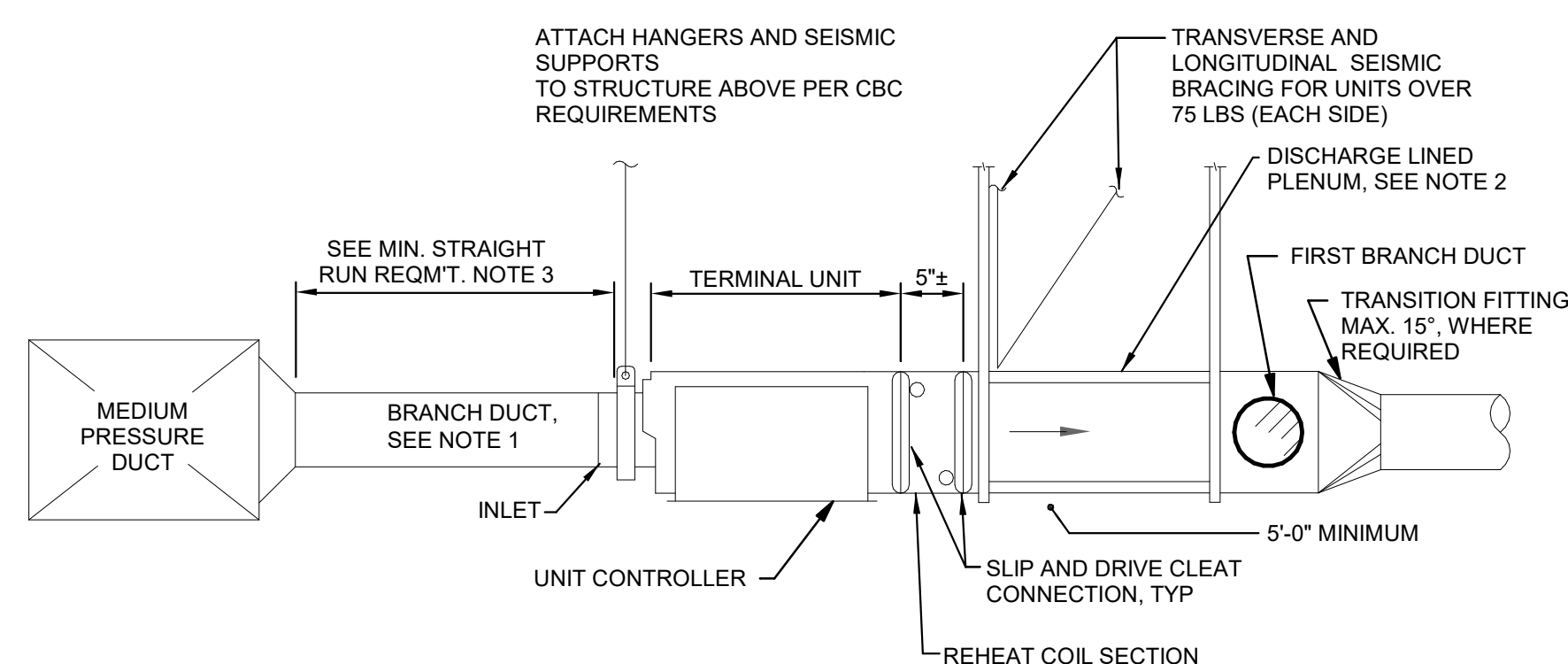

NOTES:
 1. BRANCH DUCT SIZE TO MATCH UNIT INLET CONNECTION. FOR BRANCH DUCTS OVER FIVE FEET IN LENGTH, INCREASE BRANCH DUCT ONE SIZE AND PROVIDE TRANSITION IMMEDIATELY UPSTREAM OF MINIMUM STRAIGHT DUCT RUN.
 2. MINIMUM 5'-0" LONG LINED PLENUM EQUAL TO TERMINAL BOX OUTLET SIZE. PROVIDE WITH MYLAR LINING FOR OSHPD PROJECTS.
 3. MINIMUM STRAIGHT DUCT RUN SHALL BE EQUAL TO 4 TIMES THE INLET DIAMETER OF TERMINAL UNIT.
 4. FIRST BRANCH DUCT DOWNSTREAM OF TERMINAL MUST BE A MINIMUM OF 5 FEET DOWNSTREAM OF TERMINAL UNIT.

10 TYPICAL TERMINAL UNIT DUCTING (VAV OR CAV)
 NO SCALE

TACTICAL TRAINING DESIGN

Tactical Design North, Inc.
 231 E. Buffalo St #502, Milwaukee, WI 53202

LOCAL ARCHITECT

Jacobs Wyper Architects
 1232 Chancellor St, Philadelphia, PA 19107

STRUCTURAL ENGINEER

Skidmore, Owings & Merrill LLP
 250 Greenwich St, New York, NY 10007

ELECTRICAL, PLUMBING, FIRE PROTECTION, FIRE ALARM ENGINEER

A & J Consulting Engineering Services, P.C.
 164 Brighton Rd, Clifton, NJ 07012

MECHANICAL AVIT ENGINEER

Interface Engineering, Inc.
 2000 M Street NW, Suite 270, Washington, DC 20036

ACOUSTICAL ENGINEER

Cerami
 1001 Ave of the Americas, 4th Floor, New York, NY 10018

CODE CONSULTING

CCI
 215 W 40th St, 10th Floor, New York, NY 10018

CIVIL ENGINEER

Langan
 1818 Market St #3300, Philadelphia, PA 19103

VERTICAL TRANSPORT

Michael Blades & Associates Ltd.
 5409 Rapiand Ct, Lothian, MD 20711

SIGNAGE CONSULTANT

Patricia Hord Graphik Design
 119 S. St. Asaph St, Alexandria, VA 22314

LANDSCAPE

Lee and Associates, Inc.
 638 I Street NW, Washington, DC 20001

LIGHTING

MCLA
 1000 Potomac St NW, Suite 121, Washington, DC 20007

FOOD SERVICE

Hopkins Foodservice Specialists, Inc.
 7906 MacArthur Blvd, Suite 100, Cabin John, MD 20818

POOL DESIGN

AQUA Design International
 7536 N. La Cholla Blvd, Tucson, AZ 85741

KEYPLAN

NO.	DATE	DESCRIPTION	NO.	DATE	DESCRIPTION
3	29 JUN 2023	ADDENDUM 29			
2	19 MAY 2023	ISSUED FOR BID			

RECORD REVISIONS

SIGNATURE _____ DATE _____

ARCHITECT

SOM
 Skidmore, Owings & Merrill LLP
 250 Greenwich St, New York, 10007

COMMONWEALTH OF PENNSYLVANIA
 DEPARTMENT OF GENERAL SERVICES
 HARRISBURG, PENNSYLVANIA

D.G.S. PROJECT No. **C-0211-0005 PHASE 5**

Pennsylvania State Police Academy
 Core Buildings, BESO & Sitework
 PENNSYLVANIA STATE POLICE
 HERSHEY, DAUPHIN COUNTY, PA

VERIFY SCALE

BAR IS ONE (1) INCH LONG ON ORIGINAL DRAWING: 0 1

IF BAR IS NOT ONE (1) INCH LONG, ADJUST SCALE ACCORDINGLY

CONTRACTOR SHALL FIELD VERIFY ALL DIMENSIONS. VARIANCE FROM CONTRACT DOCUMENTS NOT PERMITTED WITHOUT PROFESSIONAL & BUREAU OF CONSTRUCTION APPROVAL.

SHEET No. **FTU-M-700**

DRAWN BY	CHECKED BY	DATE	SCALE
Author	Checker		AS NOTED

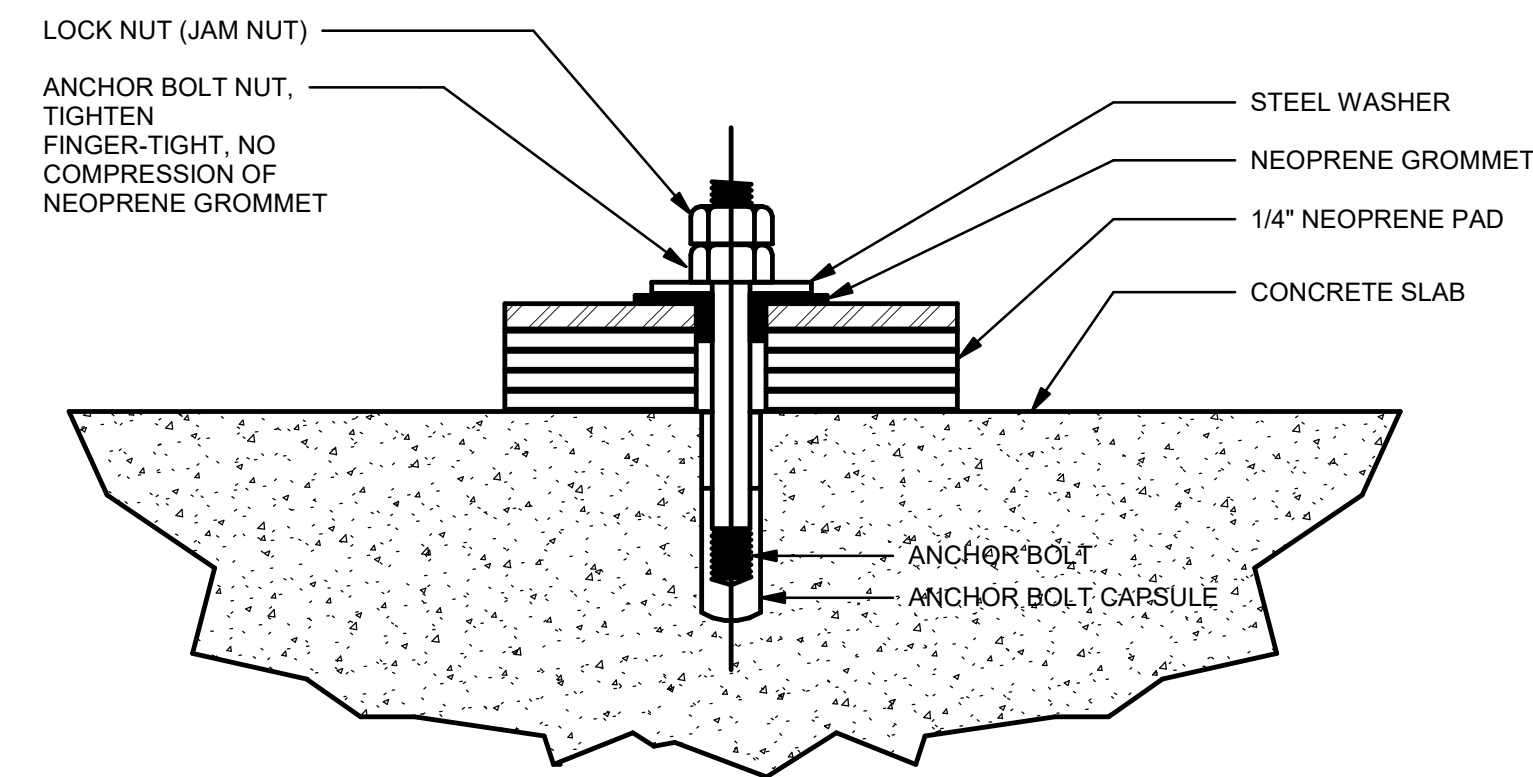

1 EQUIPMENT ANCHORAGE

NO SCALE

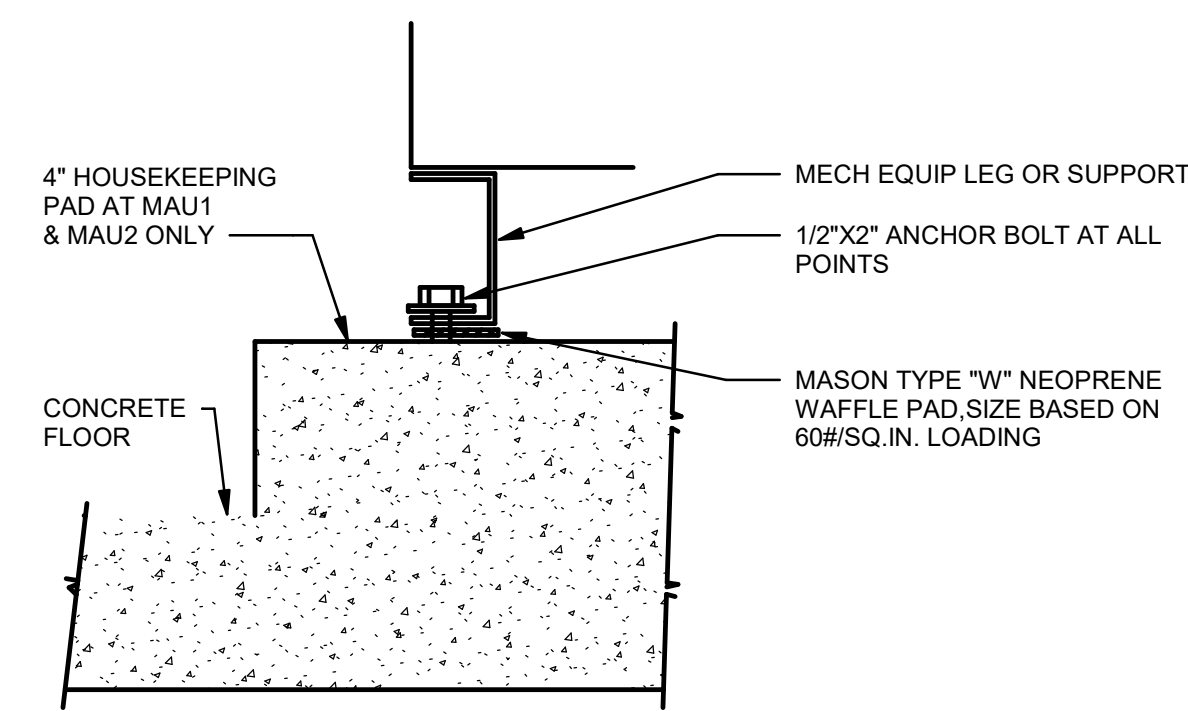

2 EQUIPMENT ATTACHMENT W/O ISOLATORS

NO SCALE

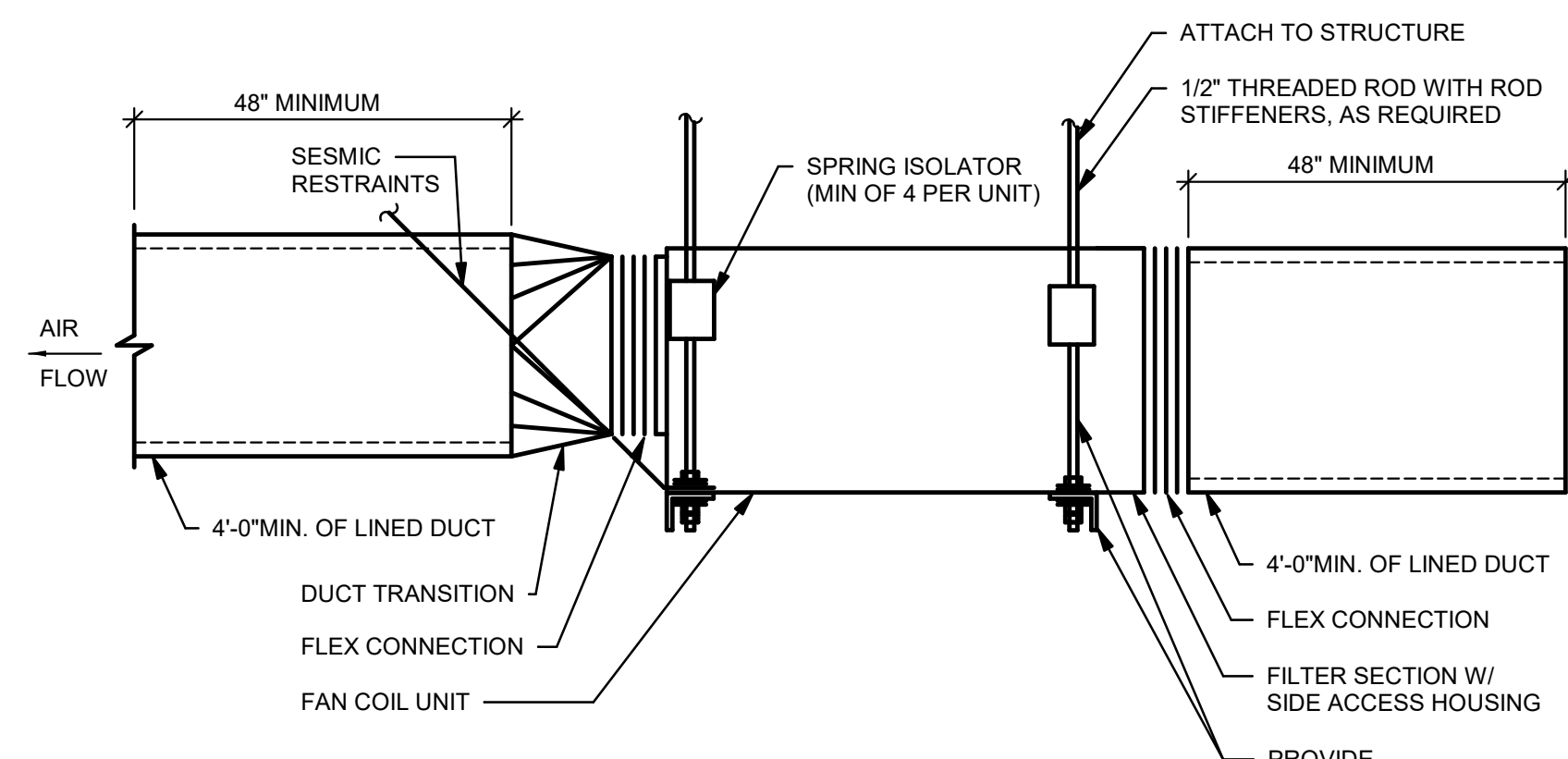

NOTE:
1. PROVIDE SEISMIC BRACING AT ALL FAN COILS. SEE SPECIFICATIONS FOR SEISMIC DESIGN CRITERIA.

3 FAN COIL UNIT HANGING DETAIL (FC-x)

NO SCALE

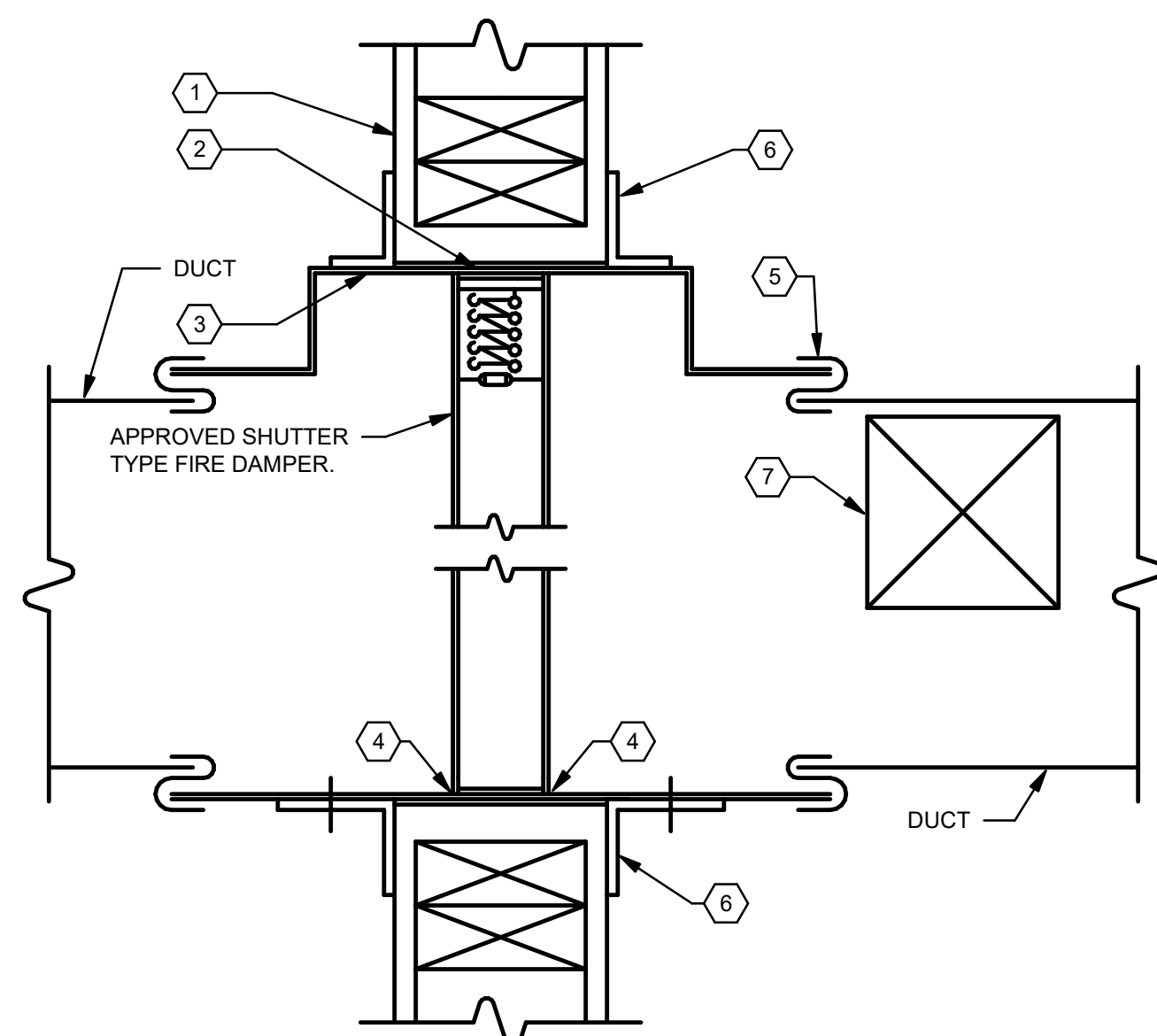

4 FIRE DAMPER

NO SCALE

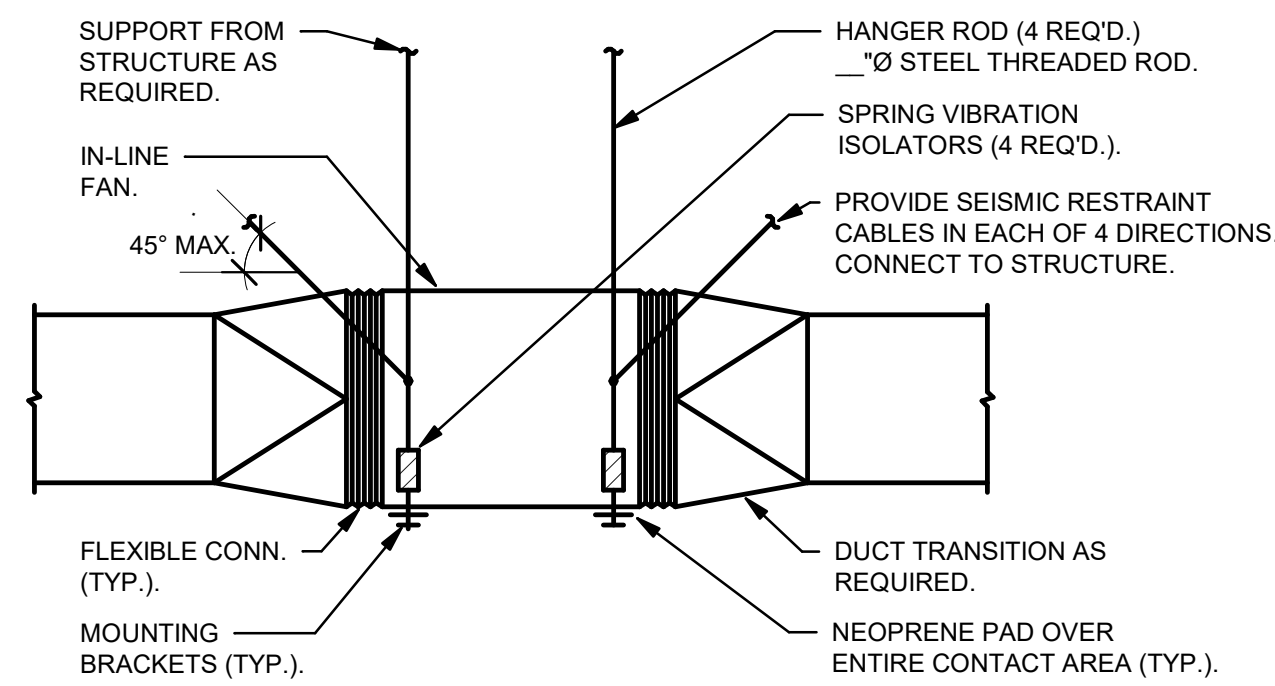

5 IN-LINE FAN

NO SCALE

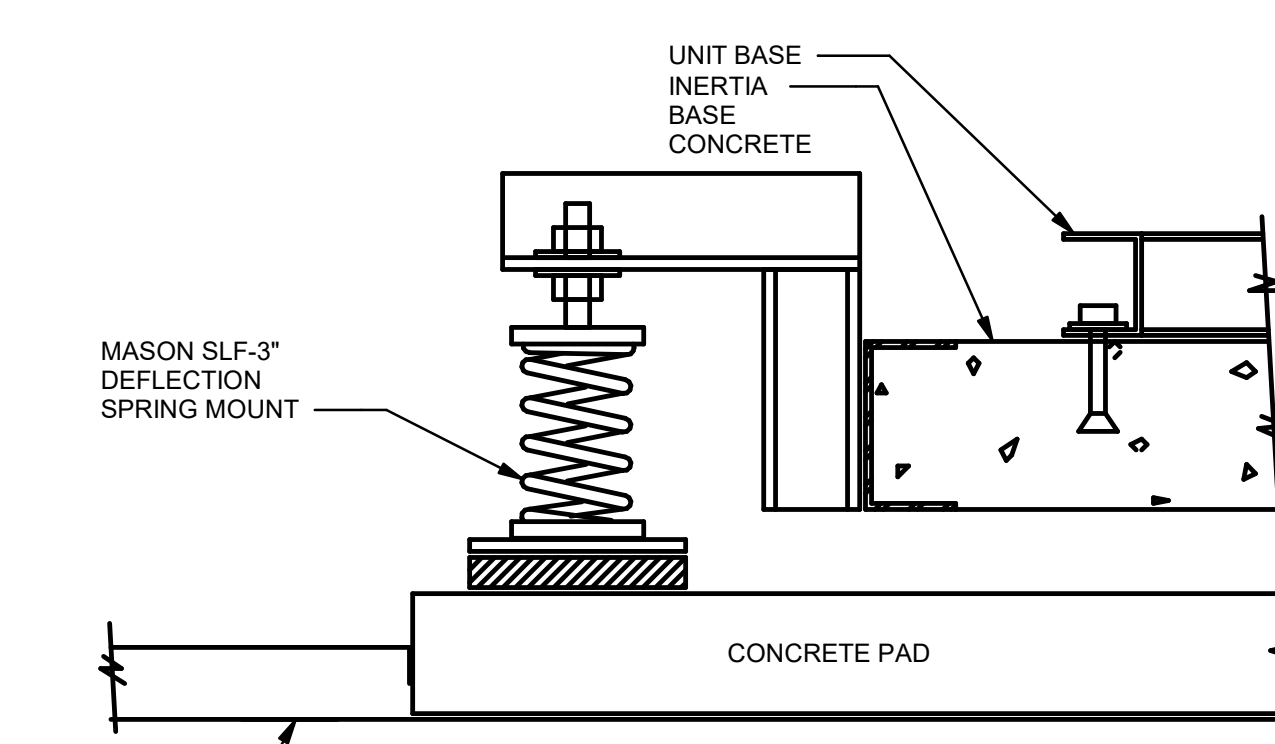

NOTE:
PROVIDE MASON Z-1225 SEISMIC SNUBBER - MIN 4

6 INERTIA BASE SUPPORT DETAIL

NO SCALE

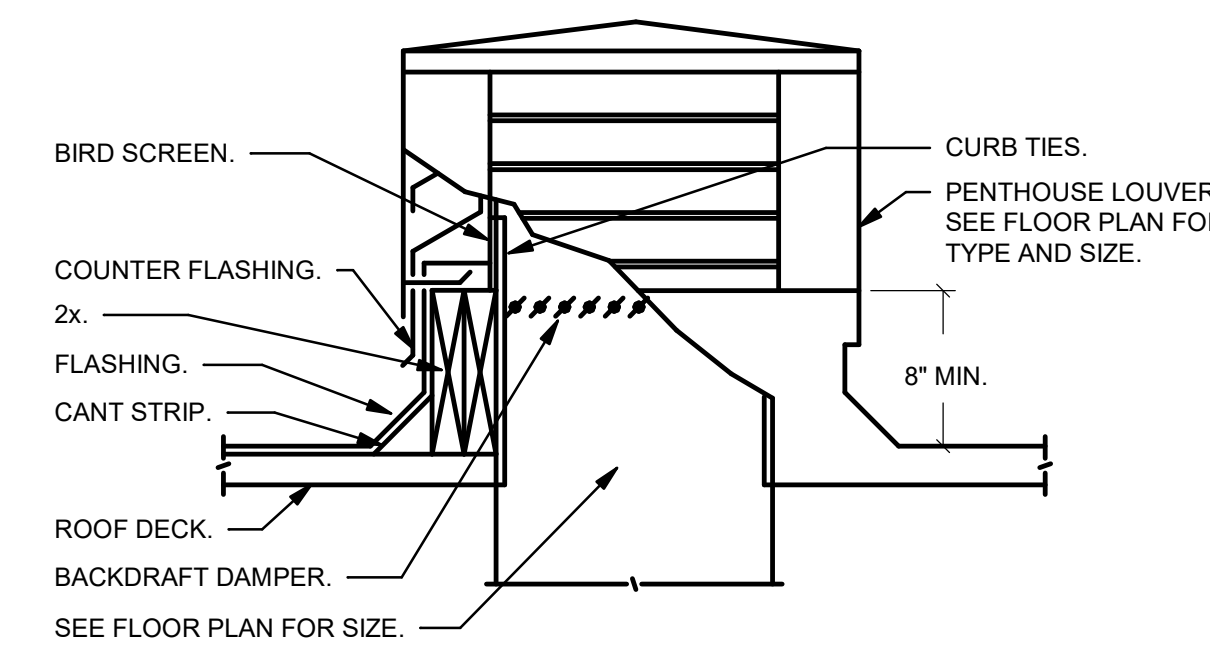

8 ROOF VENT CURB

NO SCALE

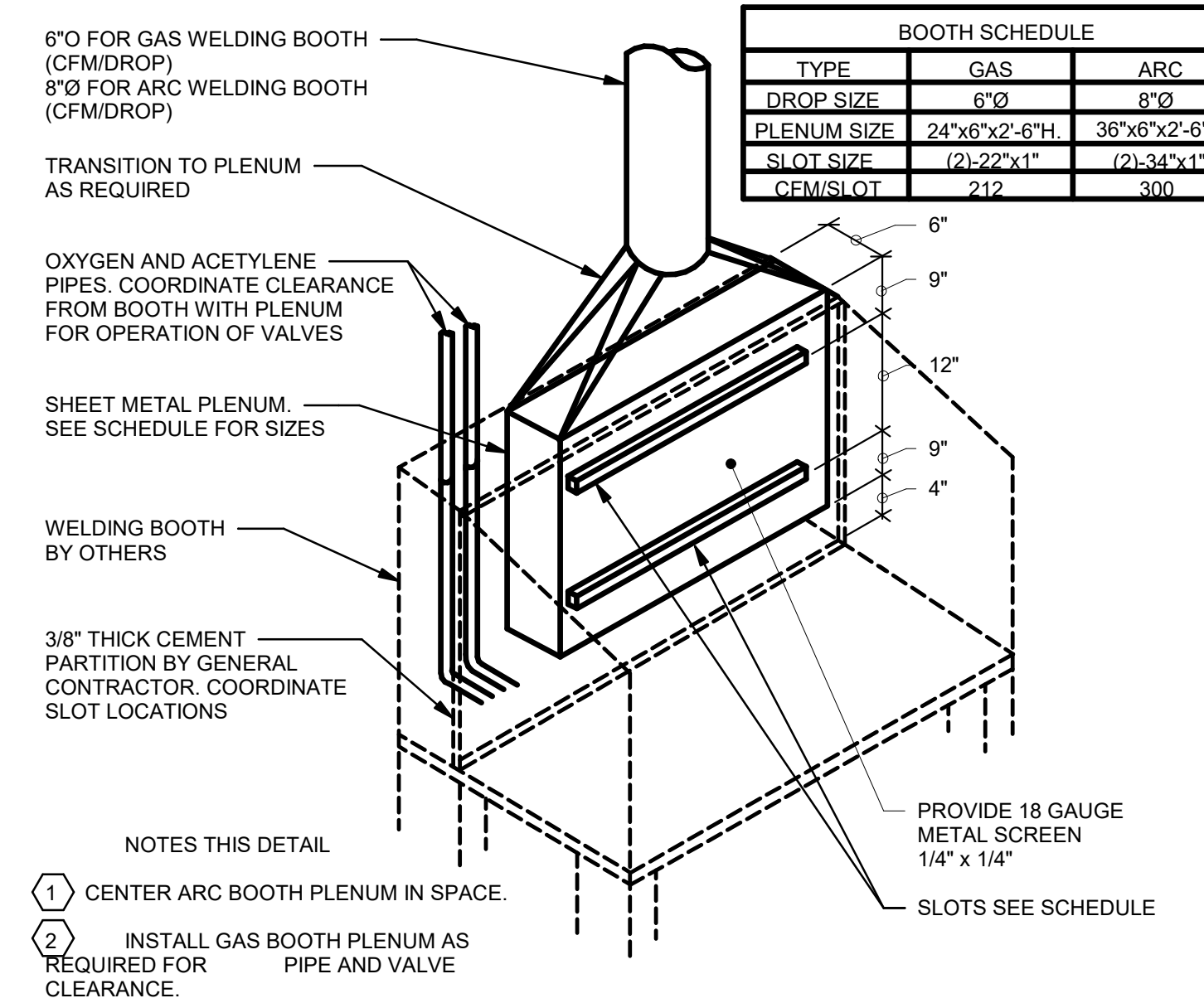

9 WELDING HOOD

NO SCALE

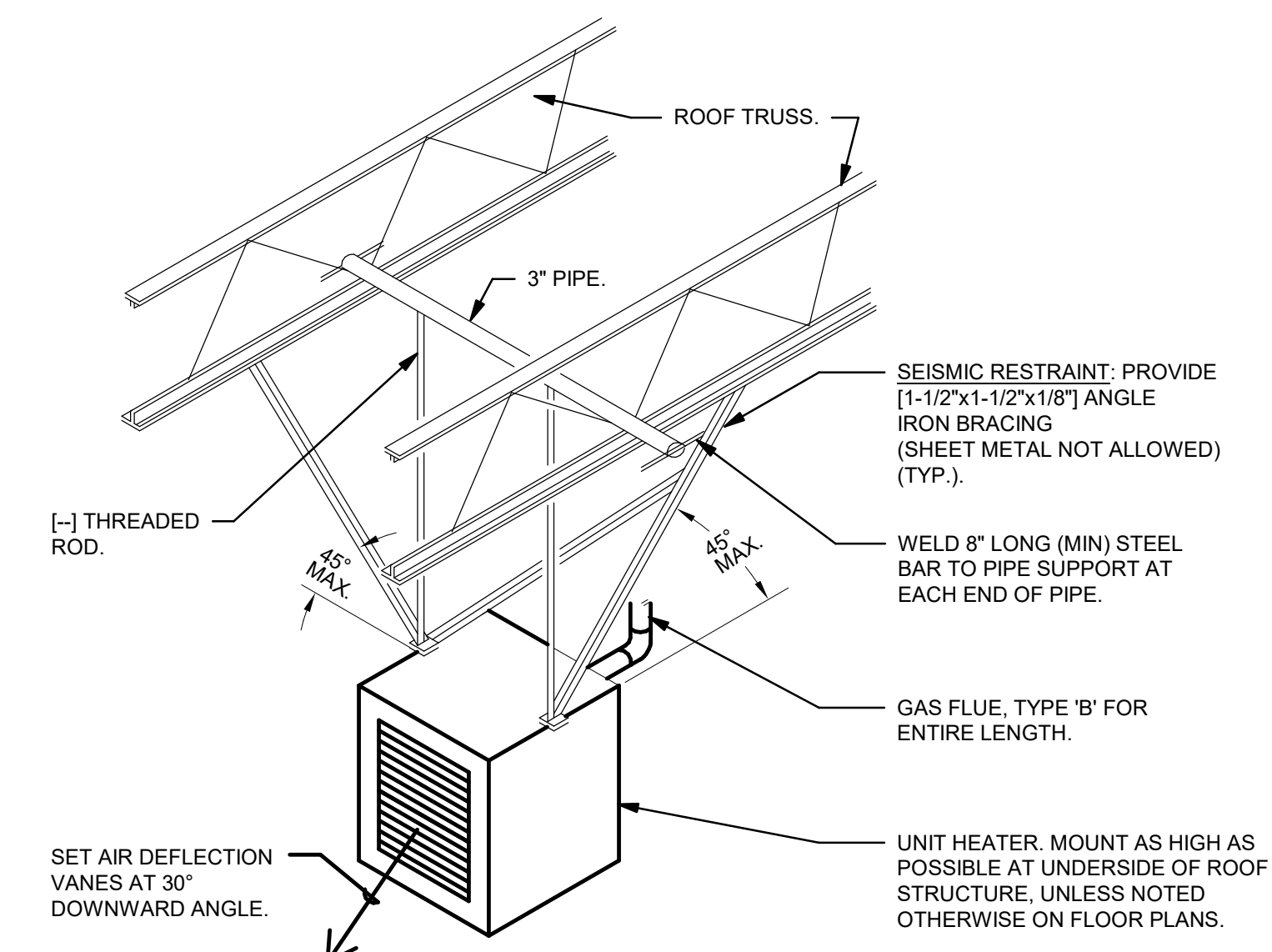

7 UNIT HEATER INSTALLATION

NO SCALE

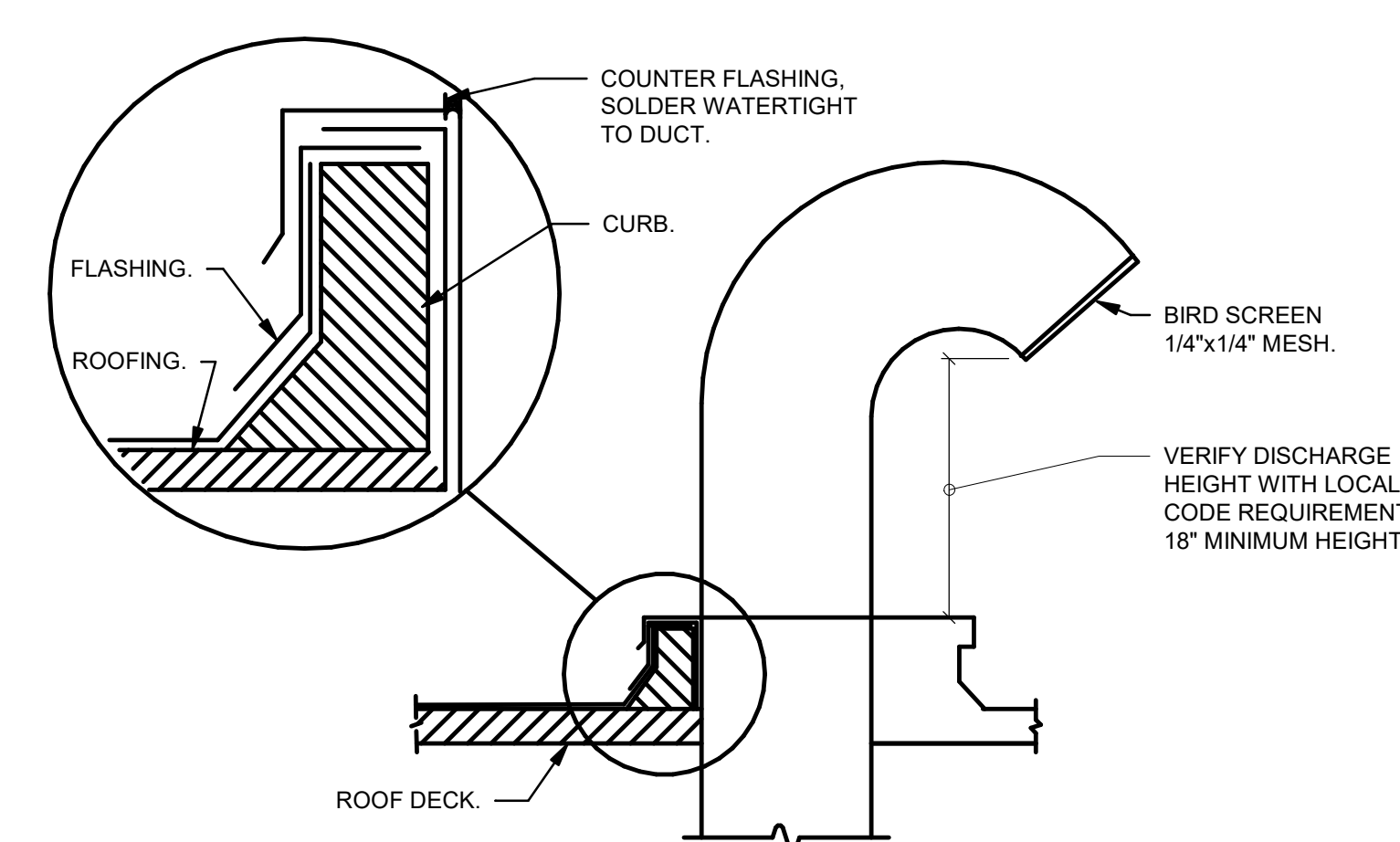

10 GOOSENECK - RECTANGULAR DUCT

NO SCALE

TACTICAL TRAINING DESIGN

Tactical Design North, Inc.
231 E. Buffalo St #502, Milwaukee, WI 53202

LOCAL ARCHITECT

Jacobs Wyper Architects
1232 Chancellor St, Philadelphia, PA 19107

STRUCTURAL ENGINEER

Skidmore, Owings & Merrill LLP
250 Greenwich St, New York, NY 10007

ELECTRICAL, PLUMBING, FIRE PROTECTION, FIRE ALARM ENGINEER

A & J Consulting Engineering Services, P.C.
164 Brighton Rd, Clifton, NJ 07012

MECHANICAL AVIATION ENGINEER

Interface Engineering, Inc.
2000 M Street NW, Suite 270, Washington, DC 20036

ACOUSTICAL ENGINEER

Cerami
1001 Ave of the Americas, 4th Floor, New York, NY 10018

CODE CONSULTING

CCI
215 W 40th St, 10th Floor, New York, NY 10018

CIVIL ENGINEER

Langan
1818 Market St #3300, Philadelphia, PA 19103

VERTICAL TRANSPORT

Michael Blades & Associates Ltd.
5409 Rapiand Ct, Lothian, MD 20711

SIGNAGE CONSULTANT

Patricia Hord Graphik Design
119 S. St. Asaph St, Alexandria, VA 22314

LANDSCAPE

Lee and Associates, Inc.
638 I Street NW, Washington, DC 20001

LIGHTING

MCLA
1000 Patomic St NW, Suite 121, Washington, DC 20007

FOOD SERVICE

Hopkins Foodservice Specialists, Inc.
7906 MacArthur Blvd, Suite 100, Cabin John, MD 20818

POOL DESIGN

AQUA Design International
7536 N. La Cholla Blvd, Tucson, AZ 85741

KEYPLAN

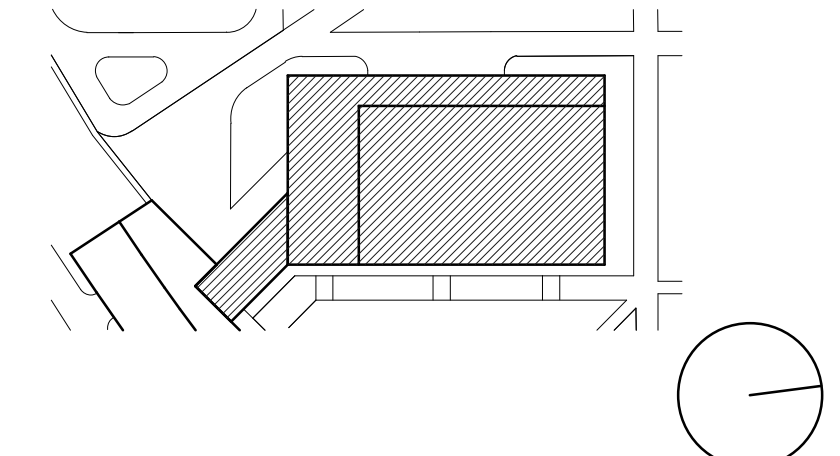

NO.	DATE	DESCRIPTION	NO.	DATE	DESCRIPTION
1	19 MAY 2023	ISSUED FOR BID			
2	29 JUN 2023	ADDENDUM 29			

SIGNATURE _____ DATE _____

ARCHITECT
SOM
Skidmore, Owings & Merrill LLP
250 Greenwich St, New York, 10007

COMMONWEALTH OF PENNSYLVANIA
DEPARTMENT OF GENERAL SERVICES
HARRISBURG, PENNSYLVANIA

D.G.S. PROJECT No. **C-0211-0005 PHASE 5**
Pennsylvania State Police Academy
Core Buildings, BESO & Sitework
PENNSYLVANIA STATE POLICE
HERSHEY, DAUPHIN COUNTY, PA

AIRSIDE DETAILS

SHEET No. **FTU-M-701**

CONTRACTOR SHALL FIELD VERIFY ALL DIMENSIONS. VARIANCE FROM CONTRACT DOCUMENTS NOT PERMITTED WITHOUT PROFESSIONAL & BUREAU OF CONSTRUCTION APPROVAL.

DRAWN BY: Author CHECKED BY: Checker DATE: SCALE: AS NOTED

VERIFY SCALE

BAR IS ONE (1) INCH LONG ON ORIGINAL DRAWING: 1

IF BAR IS NOT ONE (1) INCH LONG, ADJUST SCALE ACCORDINGLY

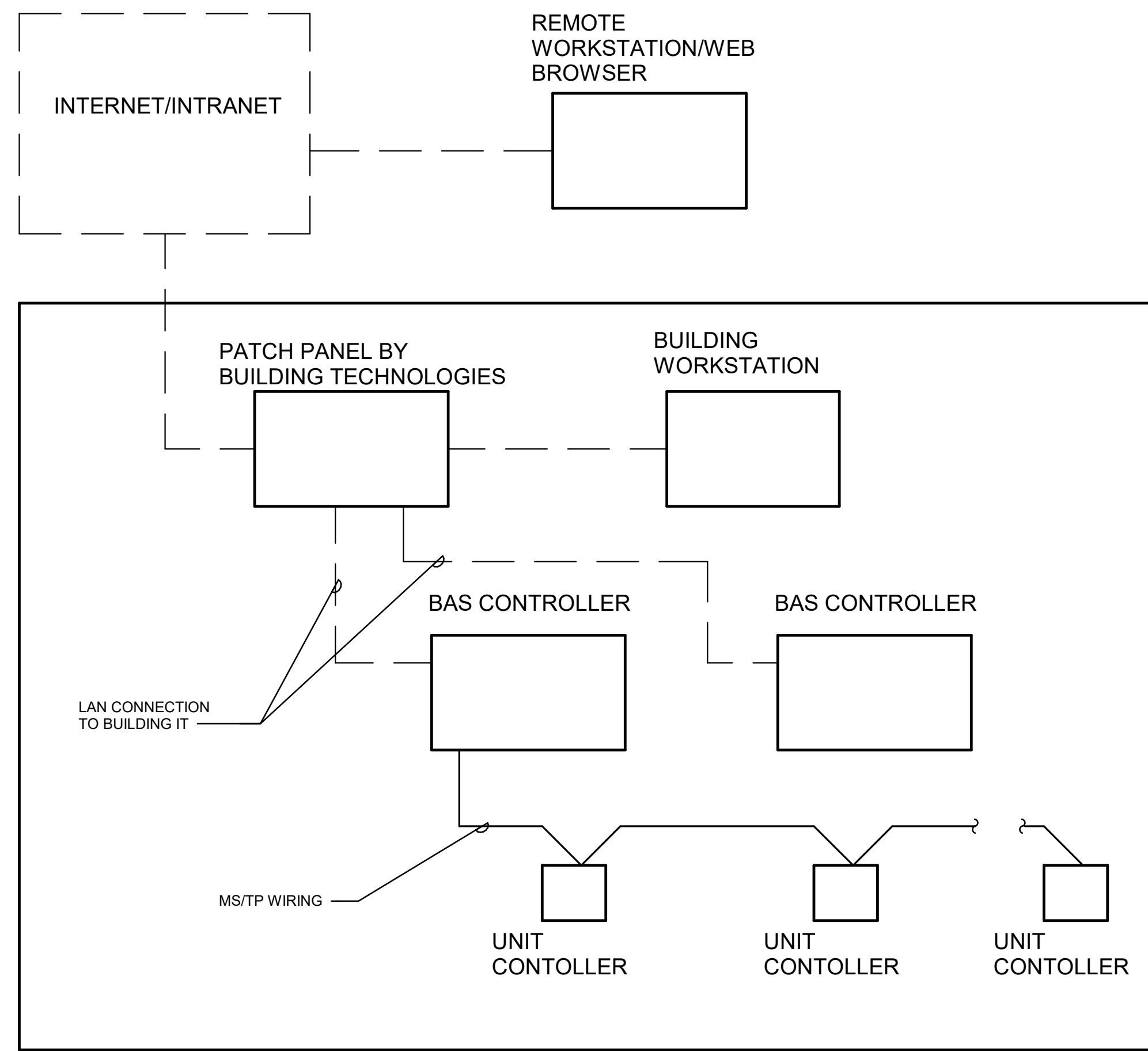

TYPICAL BUILDING

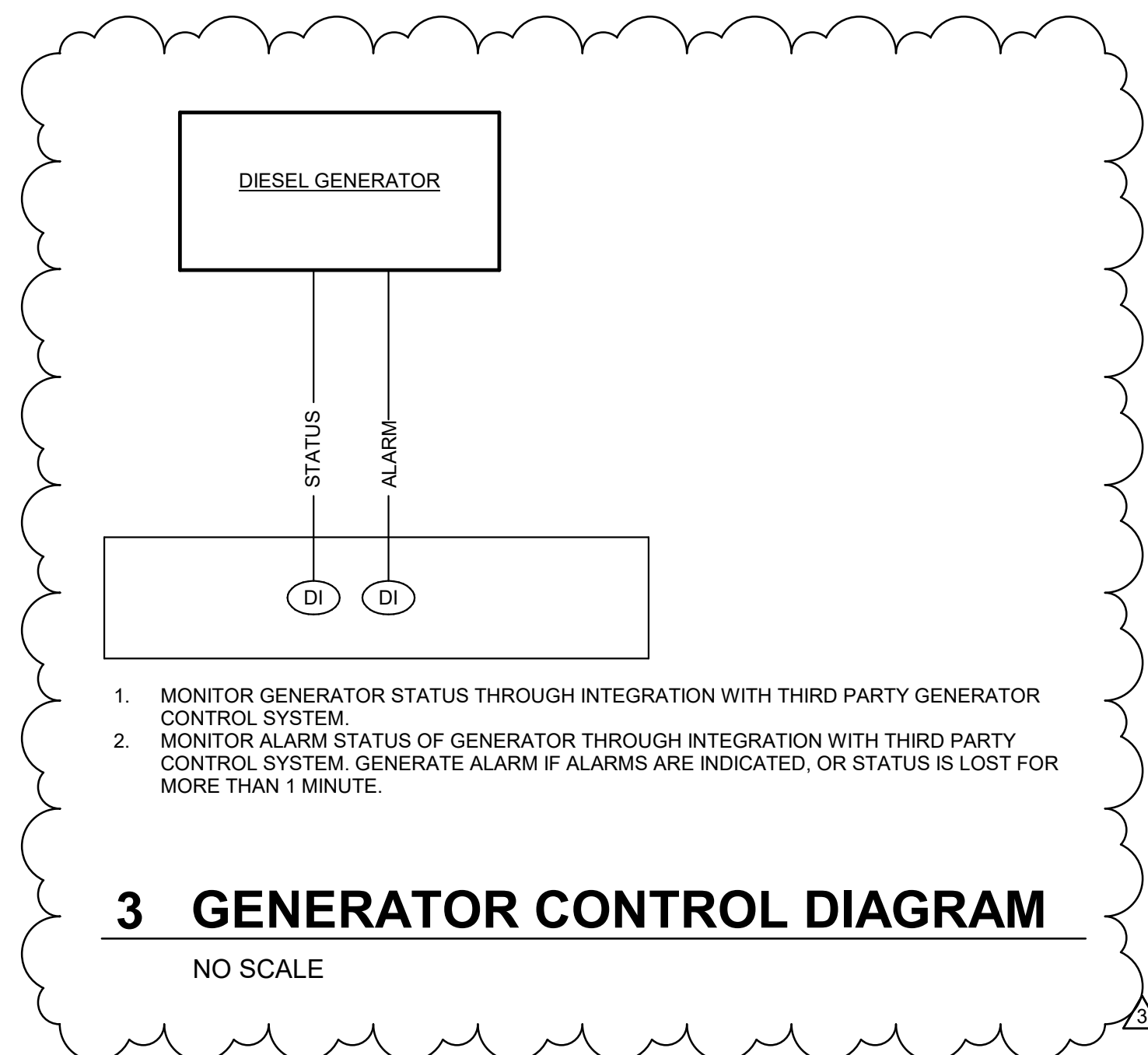

3 GENERATOR CONTROL DIAGRAM
NO SCALE

1 BAS ARCHITECTURE

NO SCALE

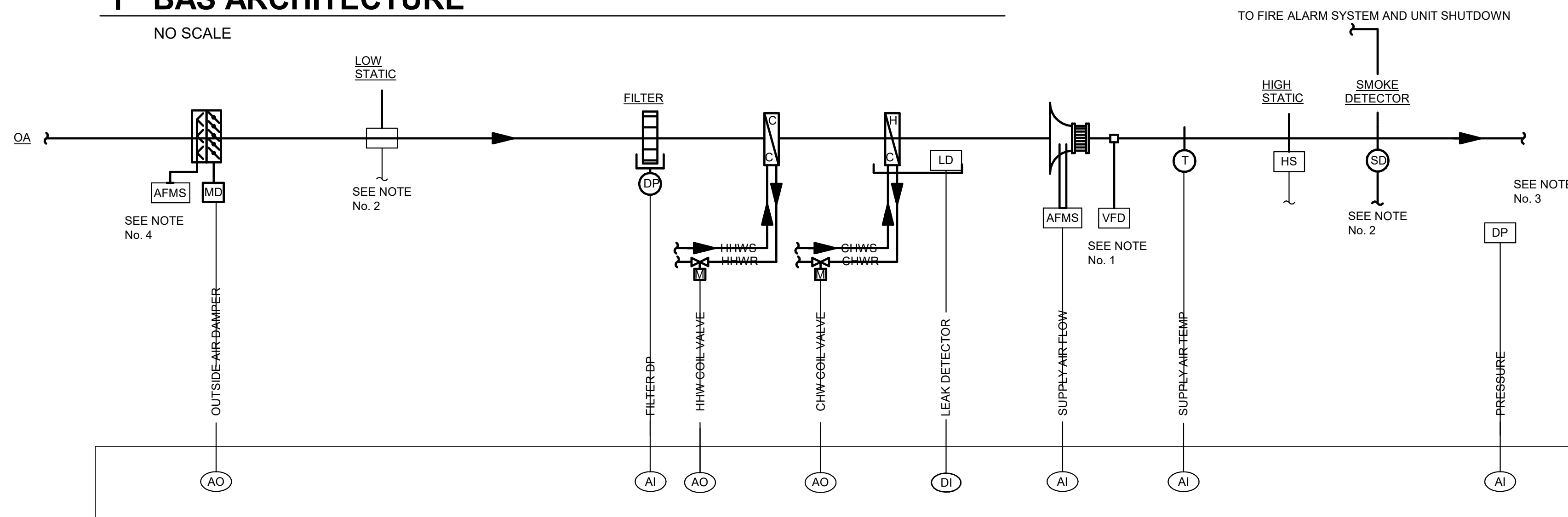

NOTES:

- SEE SCHEDULES AND AIR HANDLING UNIT DETAILS FOR QUANTITY OF FANS, VFD'S AND ECM MOTORS.
- HARDWIRE SMOKE DETECTOR AND HIGH STATIC ACTIVATIONS TO VFD/ECM MOTORS FOR FAN SHUTDOWN.
- PRESSURE SENSOR IN KITCHEN AREA.
- AIRFLOW STATION AND INTEGRAL MOTORIZED DAMPER ARE EXTERNAL TO UNIT. REFER TO PLANS FOR LOCATIONS.

GENERAL RUN CONDITIONS:

- AHU SHALL BE AUTOMATICALLY OR MANUALLY ENABLED TO RUN IN OCCUPIED MODE AS FOLLOWS:
- AUTOMATIC OPERATION
 - MANUALLY SELECTED BY USER FROM GRAPHIC INTERFACE
 - OPTIMAL START/STOP
- AHU SHALL BE STOPPED:
 - AUTOMATICALLY IN UNOCCUPIED MODE
 - MANUALLY
 - FROM SAFETY SHUTDOWNS
 - FANS SHALL RUN CONTINUOUSLY AND AS DESCRIBED HEREIN AFTER:
 - OPEN FIRE AND SMOKE DAMPERS IN DISTRIBUTION DUCTWORK. AFTER 60 SECOND DELAY STARTS THE FANS TO ALLOW FIRE AND SMOKE DAMPERS TO OPEN WITHOUT CAUSING DUCT DAMAGE.
 - START SUPPLY FAN(S).
 - FANS SHALL RUN CONTINUOUSLY AND AS DESCRIBED HEREIN AFTER.
 - OPEN NORMALLY CLOSED OUTDOOR AIR DAMPER POSITION AND RESET MINIMUM OUTDOOR AIR QUANTITY TO MINIMUM DEMAND CONTROL VENTILATION (DCV) AIR QUANTITY POSITION WHERE A DCV VALUE IS SHOWN ON SCHEDULES.
 - AUTOMATIC OPERATION:
 - AUTOMATIC OPERATION IN OCCUPIED/UNOCCUPIED MODE SHALL BE DETERMINED THROUGH A USER-ADJUSTABLE, GRAPHICAL, SEVEN-DAY ZONE OCCUPANCY SCHEDULE WITH A HOLIDAY SCHEDULE. ZONE OCCUPANCY SCHEDULE SHALL AUTOMATICALLY SELECT THE UNOCCUPIED OR OCCUPIED MODE OF THE AHU. COORDINATE SCHEDULES WITH OWNER.
 - AT THE SCHEDULED OCCUPANCY TIME, THE UNIT SHALL START IF NOT ALREADY STARTED BY THE OPTIMAL START ROUTINE, AND THE UNIT SHALL BE SWITCHED TO THE OCCUPIED MODE.
 - SCHEDULED STOP: WHEN THE TIME SCHEDULE ENTERS THE UNOCCUPIED TIME PERIOD, THE BAS SHALL STOP THE AIR HANDLING UNIT.
 - UNOCCUPIED START/STOP: IN THE UNOCCUPIED MODE, THE BAS SHALL START THE UNIT AND OPERATE THE SYSTEM IN THE UNOCCUPIED COOLING MODE IF ANY SPACE TEMPERATURE RISES ABOVE 90°F (ADJ.), OR IF THE SPACE RELATIVE HUMIDITY RISES ABOVE 65% RH. THE UNIT SHALL OPERATE UNTIL EITHER ALL SPACE TEMPERATURES HAVE DROPPED BELOW 85°F (ADJ.) AND/OR THE SPACE RELATIVE HUMIDITY HAS DROPPED BELOW 55% (WORST CASE SCENARIO). THE FANS SHALL OPERATE FOR A MINIMUM OF 30MIN OR UNTIL THERE ARE NO ZONE HEATING/COOLING REQUESTS AS DEFINED AT THE VAV CONTROL LEVEL.
 - SHUTDOWN MODE
 - SHUT DOWN UNIT ACCORDING TO BAS SCHEDULE OR IF REQUIRED DUE TO SAFETIES, AND:
 - DISABLE FANS.
 - CLOSE OUTDOOR AND RELIEF AIR DAMPERS.
 - OPEN RETURN AIR DAMPER.
 - CLOSE CHILLED WATER CONTROL VALVE.
 - 60 SECONDS (ADJ) AFTER FAN SHUTDOWN CLOSE FIRE AND SMOKE DAMPERS IN DISTRIBUTION DUCTWORK
- SUPPLY FAN CONTROL:
- SUPPLY FAN HAND-OFF-AUTO (HOA) OPERATION:
 - HOA SETTINGS SHALL BE PROVIDED AS PART OF THE VARIABLE FREQUENCY DRIVE THROUGH THE DRIVE'S KEYPAD FOR THE SUPPLY FAN. WHEN IN THE HAND MODE, THE FAN SHALL BE STARTED IN THE OFF MODE. THE FAN SHALL BE OFF. IN THE AUTO MODE, THE FAN SHALL BE STARTED AND STOPPED THROUGH THE BAS. PROVIDE AN ADJUSTABLE DELAY-ON-MAKE RELAY, WIRED IN BOTH THE HAND AND AUTO MODES, TO STAGGER THE RESTART OF EACH UNIT AFTER A POWER FAILURE TO PREVENT CREATING A SPIKE IN THE FACILITY ELECTRICAL DEMAND. UPON ACTIVATION, SAFETIES SHALL STOP THE SUPPLY FAN IN THE HAND AND AUTO MODES.
 - SUPPLY FAN AUTOMATIC SPEED CONTROL:
 - WHEN THE SUPPLY FAN(S) ARRAY IS ON, THE BAS SHALL CONTROL THE SPEED OF THE FAN ARRAY IN UNISON TO MAINTAIN SPACE STATIC PRESSURE AS SENSED BY STATIC PRESSURE SENSOR. WHEN THE SUPPLY DUCT STATIC PRESSURE IS BELOW THE SET POINT AT THE STATIC PRESSURE SENSOR(S), THE SPEED SHALL INCREASE AND WHEN SPACE STATIC PRESSURE IS ABOVE THE SET POINT AT ALL OF THE STATIC PRESSURE SENSORS, THE SPEED SHALL DECREASE. WHEN THE FAN IS OFF, THE VFD'S SHALL BE COMMANDED BY THE BAS TO THE UNLOADED POSITION (0%). THE FINAL SPACE PRESSURE SETPOINT SHALL BE DETERMINED IN CONSULTATION WITH THE BALANCING CONTRACTOR. CONDUCT STATIC PRESSURE MEASUREMENTS TO DOCUMENT COMPLIANCE. SUBMIT DOCUMENTATION FOR REVIEW AND APPROVAL PRIOR TO INSTALLING SENSORS. THE SUPPLY FAN SPEED SHALL NOT DROP BELOW 20% (ADJ.) TO PROVIDE ADEQUATE MOTOR COOLING AND PREVENT FAN STALLING PHENOMENA.
 - FOR UNITS WITH MULTIPLE VFD'S, WITHOUT A STANDBY VFD, VARY THE SPEED OF VFD'S IN UNISON. SHUT DOWN LAG VFD WHEN THE SPEED OF VFD'S IS AT MINIMUM AND TURN ON THE LAG VFD(S) WHEN THE SPEED OF OPERATING VFD(S) IS AT 85 PERCENT OF PEAK SPEED OR AT FAILURE OF LEAD FAN(S) OR LEAD VFD. ON FAILURE OF LEAD FAN(S) OR LEAD VFD SHUT DOWN LEAD VFD AND START LAG VFD THROUGH HARDWARE CONNECTION BETWEEN VFD'S.
 - AN AIRFLOW MONITORING STATION SHALL CONTINUOUSLY MONITOR THE TOTAL SUPPLY AIR FAN VOLUME IN CFM AND SEND AN OUTPUT TO THE BAS.

SPACE TEMPERATURE SET POINT CONTROL:

- THE BAS SHALL MAINTAIN THE SPACE TEMPERATURE SET POINT ACCORDING TO THE FOLLOWING. SPACE TEMPERATURE CONTROL SHALL BE RESTRICTED SUCH THAT THE SUPPLY AIR TEMPERATURE SHALL NEVER FALL BELOW 55°F (ADJ) OR RISE ABOVE 85°F (ADJ)
 - OCCUPIED COOLING SET POINT - 75°F

CHILLED WATER VALVE CONTROL:

- WHEN THE UNIT STATUS IS OFF, THE CHILLED WATER VALVE SHALL BE CLOSED. WHEN THE UNIT STATUS IS ON, THE CHILLED WATER VALVE SHALL BE CONTROLLED AS DESCRIBED BELOW:
 - OCCUPIED MODE: IN THE OCCUPIED MODE, THE BAS SHALL MODULATE THE CHILLED WATER VALVE LAST IN SEQUENCE TO MAINTAIN AHU DISCHARGE AIR LEAVING TEMPERATURE COOLING SETPOINT, NORMALLY LIMITED TO 55°F (ADJ.).

HOT WATER VALVE CONTROL:

- WHEN THE UNIT STATUS IS OFF, THE HOT WATER VALVE SHALL BE CLOSED. WHEN THE UNIT STATUS IS ON, THE HOT WATER VALVE SHALL BE CONTROLLED AS DESCRIBED BELOW:
 - OCCUPIED MODE: IN THE OCCUPIED MODE, THE BAS SHALL MODULATE THE HOT WATER VALVE LAST IN SEQUENCE TO MAINTAIN AHU DISCHARGE AIR LEAVING TEMPERATURE HEATING SETPOINT, NORMALLY LIMITED TO 60°F (ADJ.).

SAFETY SHUTDOWNS AND ALARMS:

- FIRE ALARM SHUTDOWN CONTROL:
 - THE SUPPLY AND EXHAUST FANS SHALL BE INTERLOCKED WITH THE FIRE ALARM SYSTEM THROUGH A CONTROL MODULE (CM). THE CONTROL MODULE SHALL BE HARD WIRE INTERLOCKED TO CONTROL THE SUPPLY FAN IN THE HAND AND AUTO OPERATING MODES. EXHAUST FAN SHUTDOWN WILL OCCUR THROUGH THE HARDWIRE INTERLOCK WITH THE SUPPLY FAN.
 - SMOKE DAMPERS INSTALLED IN THE SUPPLY AND EXHAUST DUCT MAINS AT THE AHU SHALL BE INTERLOCKED WITH THE FIRE ALARM SYSTEM THROUGH A CONTROL MODULE (CM). THE CONTROL MODULE SHALL BE HARD WIRE INTERLOCKED TO CONTROL THE SMOKE DAMPER. CONTRACTOR SHALL COORDINATE WITH PLANS AND PROVIDE CONTROL POINTS, SEQUENCES AND GRAPHICS AS REQUIRED.
 - THE DUCT SMOKE DETECTOR LOCATED IN THE SUPPLY/RETURN AIR OF THE UNIT WILL BE MONITORED BY THE FIRE ALARM SYSTEM. THE FIRE ALARM SYSTEM SHALL BE PROGRAMMED TO ACTIVATE THE CONTROL MODULE AND THE SYSTEM SHALL OPERATE AS FOLLOWS:
 - WHEN PRODUCTS OF COMBUSTION ARE SENSED BY THE SUPPLY/RETURN AIR DUCT SMOKE DETECTOR, THE CONTROL MODULES SHALL STOP THE FANS IN THE HAND AND AUTO OPERATING MODES AND CLOSE THE ASSOCIATED SMOKE DAMPERS.
 - WHEN THE PRODUCTS OF COMBUSTION ARE CLEARED AND THE FIRE ALARM SYSTEM IS RESET, THE CONTROL MODULE SHALL RESTORE NORMAL CONTROL TO THE FANS.
- HIGH PRESSURE SWITCH:
 - WHEN THE HIGH PRESSURE SWITCH TRIPS, THE UNIT SHALL BE STOPPED THROUGH A HARD WIRE INTERLOCK. AN ALARM SHALL BE GENERATED IN THE BAS AND DISPLAYED AT THE OWS. THE HIGH PRESSURE SWITCH SHALL BE SET TO TRIP AT 4" WC. (MANUALLY ADJUSTABLE) AND MUST BE MANUALLY RESET AT THE HIGH PRESSURE SWITCH.
- LOW PRESSURE SWITCH:
 - PRESSURE SWITCH SHALL DISABLE RETURN FAN IF FIRE/SMOKE DAMPER IN RETURN DUCT CLOSES. WHEN THE LOW PRESSURE SWITCH TRIPS, THE UNIT SHALL BE STOPPED THROUGH A HARD WIRE INTERLOCK. AN ALARM SHALL BE GENERATED IN THE BAS. THE LOW PRESSURE SWITCH SHALL BE SET TO TRIP AT -3" WC. (MANUALLY ADJUSTABLE) AND MUST BE MANUALLY RESET AT THE LOW PRESSURE SWITCH.
- DIRTY FILTER ALARM:
 - DIFFERENTIAL PRESSURE SWITCHES SHALL MONITOR THE PRESSURE DROP AT THE FILTERS. WHEN THE PRESSURE EXCEEDS AN ADJUSTABLE LIMIT, AN ALARM SIGNAL WILL BE SENT. PRESSURE DIFFERENCE INDICATORS, LOCATED AT THE FILTERS, SHALL INDICATE THE DIFFERENTIAL PRESSURE ACROSS THE FILTERS. EACH FILTER SHALL BE PROVIDED WITH INDIVIDUAL DIRTY PRESSURE SETPOINTS. FILTERS MAY NOT BE COMBINED FOR A SINGLE DIRTY PRESSURE DIFFERENTIAL.
- OUTSIDE AIRFLOW ALARM:
 - WHENEVER THE OUTSIDE AIRFLOW, AS MEASURED BY THE UNIT'S OA AFMS, VARIES FROM THE SETPOINT BY MORE THAN 15% FOR MORE THAN 15MIN(ADJ.), AN ALARM SHALL BE RAISED TO THE BAS.
- FAN STATUS:
 - THE CURRENT RELAYS SHALL BE USED TO MONITOR THE STATUS OF THE UNIT SUPPLY AND EXHAUST FANS. IF THE STATUS INDICATED DOES NOT MATCH THE COMMANDED OUTPUT FOR A FAN, AN ALARM SHALL BE GENERATED.
- TEMPERATURE AND HUMIDITY ALARM:
 - AN ALARM SHALL BE GENERATED AT THE BAS IF THE SUPPLY AIR DISCHARGE TEMPERATURE IS ABOVE OR BELOW SETPOINT BY +/-5°F

2 MAKE UP AIR SYSTEM CONTROL DIAGRAM (F-MAU-1, F-MAU-2)

NO SCALE

TACTICAL TRAINING DESIGN

Tactical Design North, Inc.
231 E. Buffalo St #502, Milwaukee, WI 53202

LOCAL ARCHITECT

Jacobs Wyper Architects
1232 Chancellor St, Philadelphia, PA 19107

STRUCTURAL ENGINEER

Skidmore, Owings & Merrill LLP
250 Greenwich St, New York, NY 10007

ELECTRICAL, PLUMBING, FIRE PROTECTION, FIRE ALARM ENGINEER

A & J Consulting Engineering Services, P.C.
164 Brighton Rd, Clifton, NJ 07012

MECHANICAL, AVIT ENGINEER

Interface Engineering, Inc.
2000 M Street NW, Suite 270, Washington, DC 20036

ACOUSTICAL ENGINEER

Cerami
1001 Ave of the Americas, 4th Floor, New York, NY 10018

CODE CONSULTING

CCI
215 W 40th St, 10th Floor, New York, NY 10018

CIVIL ENGINEER

Langan
1818 Market St #3300, Philadelphia, PA 19103

VERTICAL TRANSPORT

Michael Blades & Associates Ltd.
5409 Rapiidan Ct, Lothian, MD 20711

SIGNAGE CONSULTANT

Patricia Hord Graphik Design
119 S. St. Asaph St, Alexandria, VA 22314

LANDSCAPE

Lee and Associates, Inc.
638 I Street NW, Washington, DC 20001

LIGHTING

MCLA
1000 Patomic St NW, Suite 121, Washington, DC 20007

FOOD SERVICE

Hopkins Foodservice Specialists, Inc.
7906 MacArthur Blvd, Suite 100, Cabin John, MD 20818

POOL DESIGN

AQUA Design International
7536 N. La Cholla Blvd, Tucson, AZ 85741

KEYPLAN

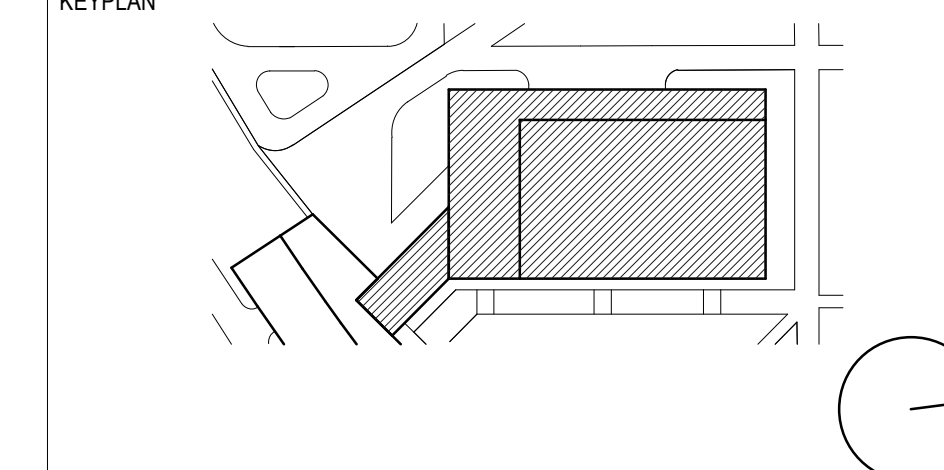

NO.	DATE	DESCRIPTION	NO.	DATE	DESCRIPTION
3	29 JUN 2023	ADDENDUM 29			
2	19 MAY 2023	ISSUED FOR BID			

RECORD REVISIONS

SEAL

SIGNATURE _____ DATE _____

ARCHITECT
SOM
Skidmore, Owings & Merrill LLP
250 Greenwich St, New York, 10007

COMMONWEALTH OF PENNSYLVANIA
DEPARTMENT OF GENERAL SERVICES
HARRISBURG, PENNSYLVANIA

D.G.S. PROJECT No. **C-0211-0005 PHASE 5**

Pennsylvania State Police Academy
Core Buildings, BESO & Sitework
PENNSYLVANIA STATE POLICE
HERSHEY, DAUPHIN COUNTY, PA

CONTROLS - MECHANICAL

SHEET No. **FTU-M-802**

DRAWN BY Author	CHECKED BY Checker	DATE	SCALE AS NOTED
--------------------	-----------------------	------	-------------------

VERIFY SCALE

BAR IS ONE (1) INCH LONG
ON ORIGINAL DRAWING: 0 1

IF BAR IS NOT ONE (1) INCH LONG, ADJUST SCALE ACCORDINGLY

CONTRACTOR SHALL FIELD VERIFY ALL DIMENSIONS. VARIANCE FROM CONTRACT DOCUMENTS NOT PERMITTED WITHOUT PROFESSIONAL & BUREAU OF CONSTRUCTION APPROVAL.

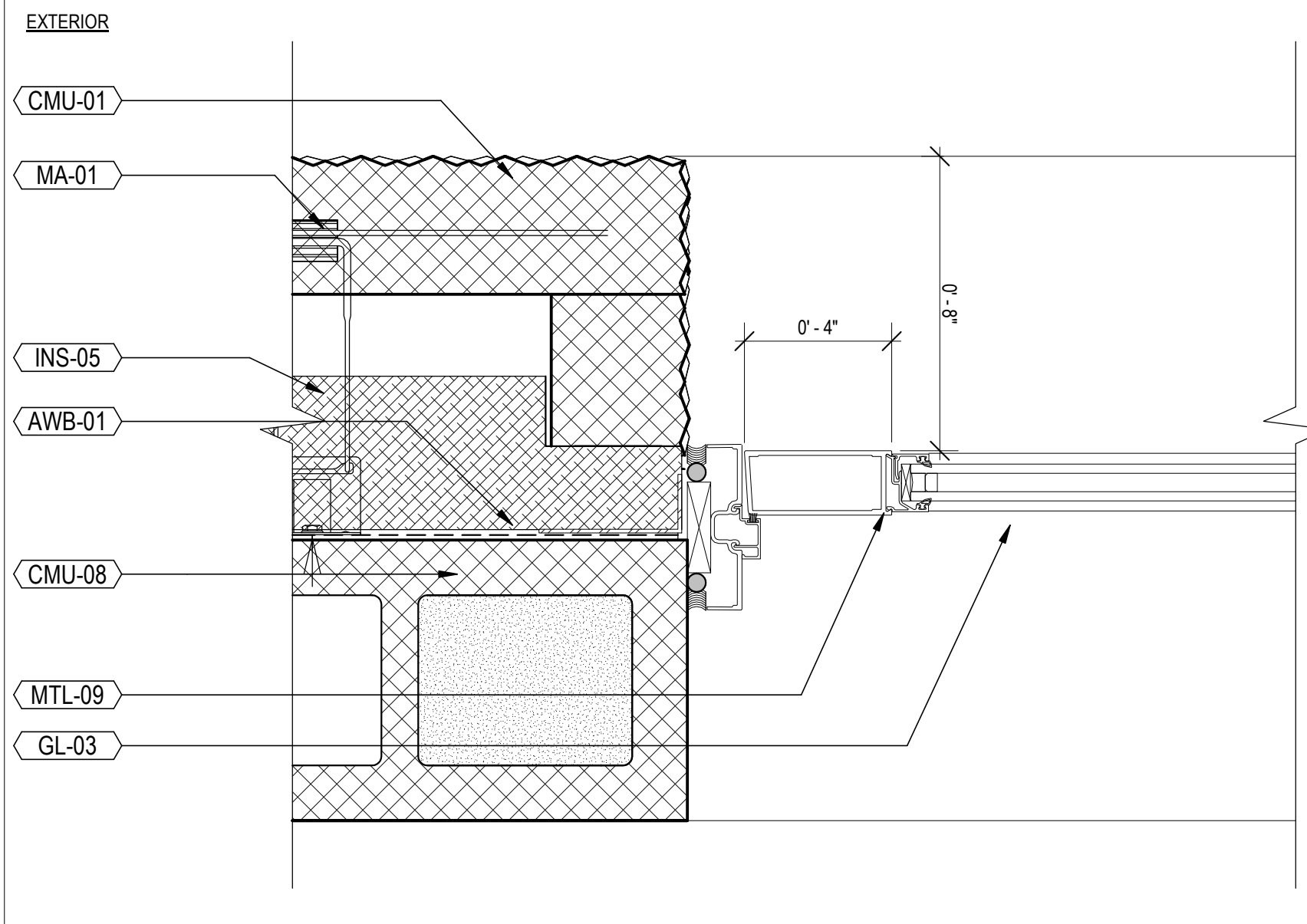

9 EXT DETAILS - STOREFRONT DOOR JAMB
SCALE: 3" = 1'-0"

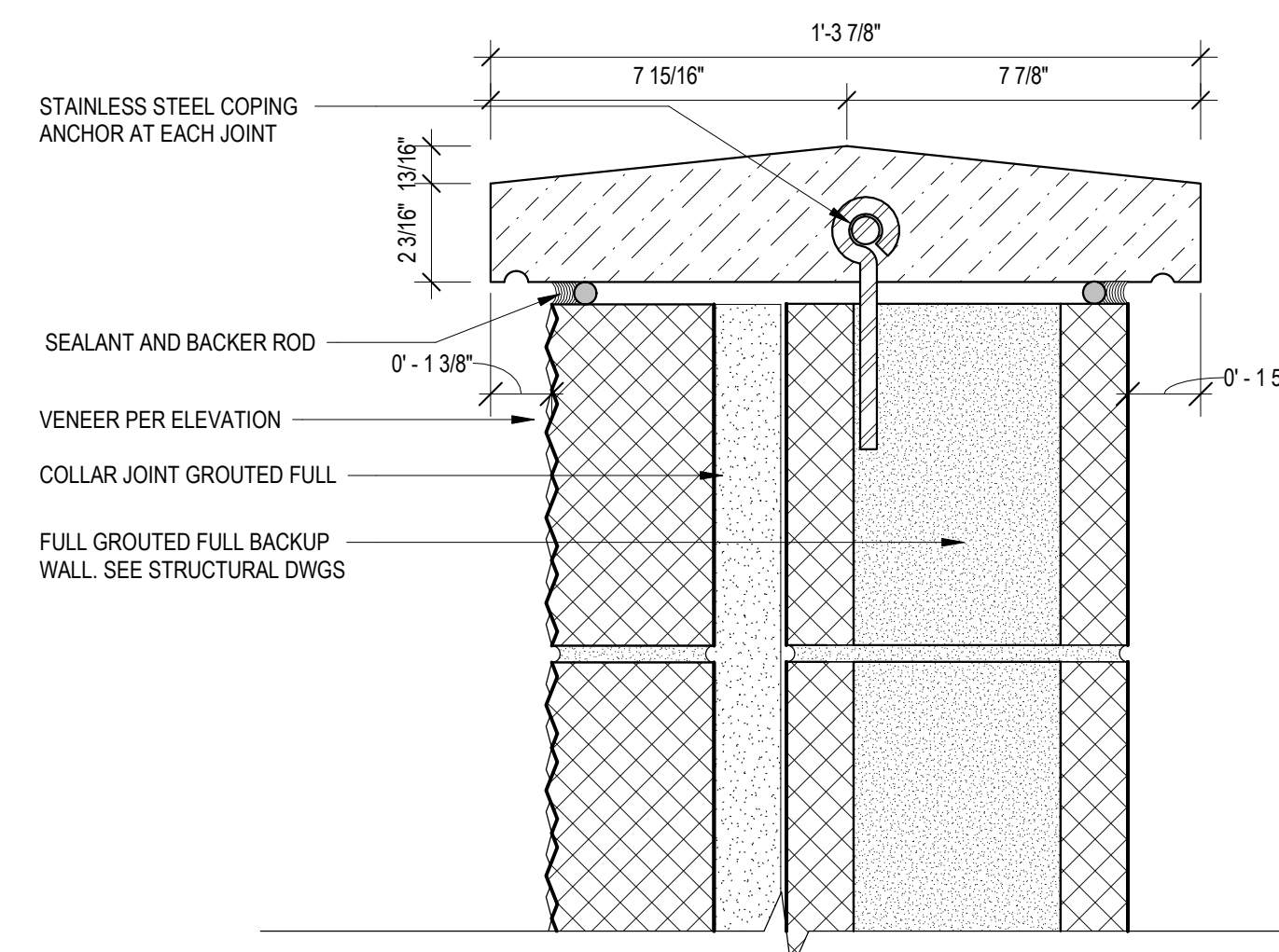

6 SITE WALL COPING DETAIL
SCALE: 3" = 1'-0"

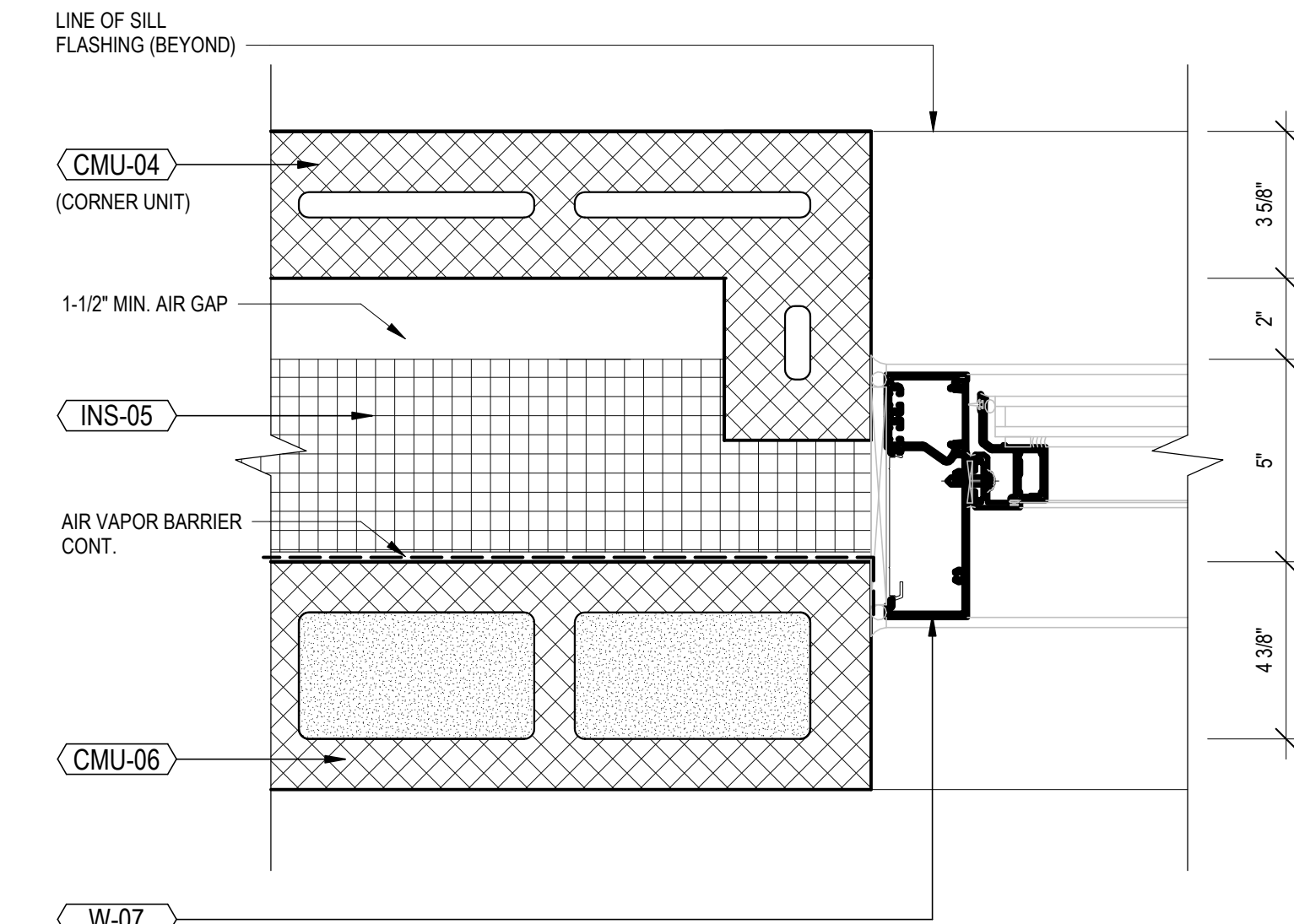

3 KENNEL WINDOW JAMB
SCALE: 3" = 1'-0"

KEYNOTES	
AWB-01	072700 AIR BARRIERS
CMU-01	042000 CONCRETE MASONRY UNIT, 8" X 24" X 4" SPLIT FACE
CMU-02	042000 CONCRETE MASONRY UNIT, 8" X 24" X 8" GROUND FACE
CMU-04	042000 CONCRETE MASONRY UNIT, 8" X 16" X 4"
CMU-06	042000 CONCRETE MASONRY UNIT, 8" X 16" X 8"
GL-03	088000 EXTERIOR IGU ULTRA-CLEAR
GWB-01	092116 5/8" TYPE 'X' GYPSUM BOARD
MRPA-07	074113 MANUFACTURER'S STANDING SEAM METAL CLOSURE
INS-05	072100 SEMI-RIGID MINERAL FIBER INSULATION
MA-01	042000 MASONRY TIE
MFABA-01	055000 HEAD LINTEL
MFABA-02	055000 SILL ANGLE
MP-01	014213 RAINSCREEN METAL PANEL SYSTEM
MTL-09	057000 POWDER COATED ALUMINUM, DARK GRAY
RWA-06	077000 METAL COPING MP-01
W-07	085113 PEMB WINDOWS - OPERABLE

TACTICAL TRAINING DESIGN

Tactical Design North, Inc.
231 E. Buffalo St #502, Milwaukee, WI 53202

LOCAL ARCHITECT

Jacobs Wyper Architects
1232 Chancellor St, Philadelphia, PA 19107

STRUCTURAL ENGINEER

Skidmore, Owings & Merrill LLP
250 Greenwich St, New York, NY 10007

ELECTRICAL, PLUMBING, FIRE PROTECTION, FIRE ALARM ENGINEER

A & J Consulting Engineering Services, P.C.
164 Brighton Rd, Clifton, NJ 07012

MECHANICAL AVIT ENGINEER

Interface Engineering, Inc.
2000 M Street NW, Suite 270, Washington, DC 20036

ACOUSTICAL ENGINEER

Cerami
1001 Ave of the Americas, 4th Floor, New York, NY 10018

CODE CONSULTANT

CCI
215 W 40th St, 10th Floor, New York, NY 10018

CIVIL ENGINEER

Langan
1818 Market St #3300, Philadelphia, PA 19103

VERTICAL TRANSPORT

Michael Blades & Associates Ltd.
5409 Rapihan Ct, Lothian, MD 20711

SIGNAGE CONSULTANT

Patricia Hord Graphik Design
119 S. St. Asaph St, Alexandria, VA 22314

LANDSCAPE

Lee and Associates, Inc.
638 I Street NW, Washington, DC 20001

LIGHTING

MCLA
1000 Patomic St NW, Suite 121, Washington, DC 20007

FOOD SERVICE

Hopkins Foodservice Specialists, Inc.
7906 MacArthur Blvd, Suite 100, Cabin John, MD 20818

POOL DESIGN

AQUA Design International
7536 N. La Cholla Blvd, Tucson, AZ 85741

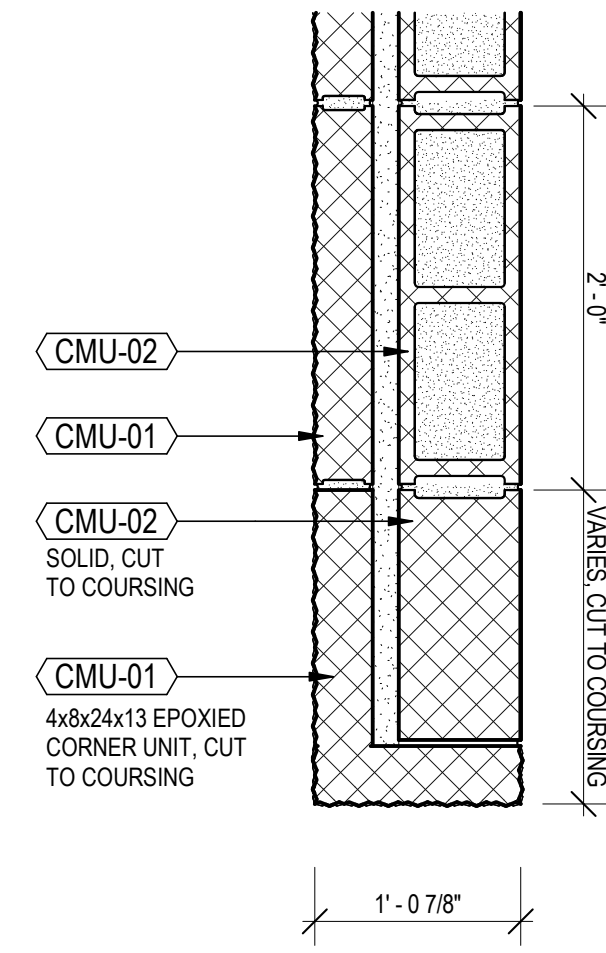

11 SITE WALL PLAN DTL
SCALE: 1" = 1'-0"

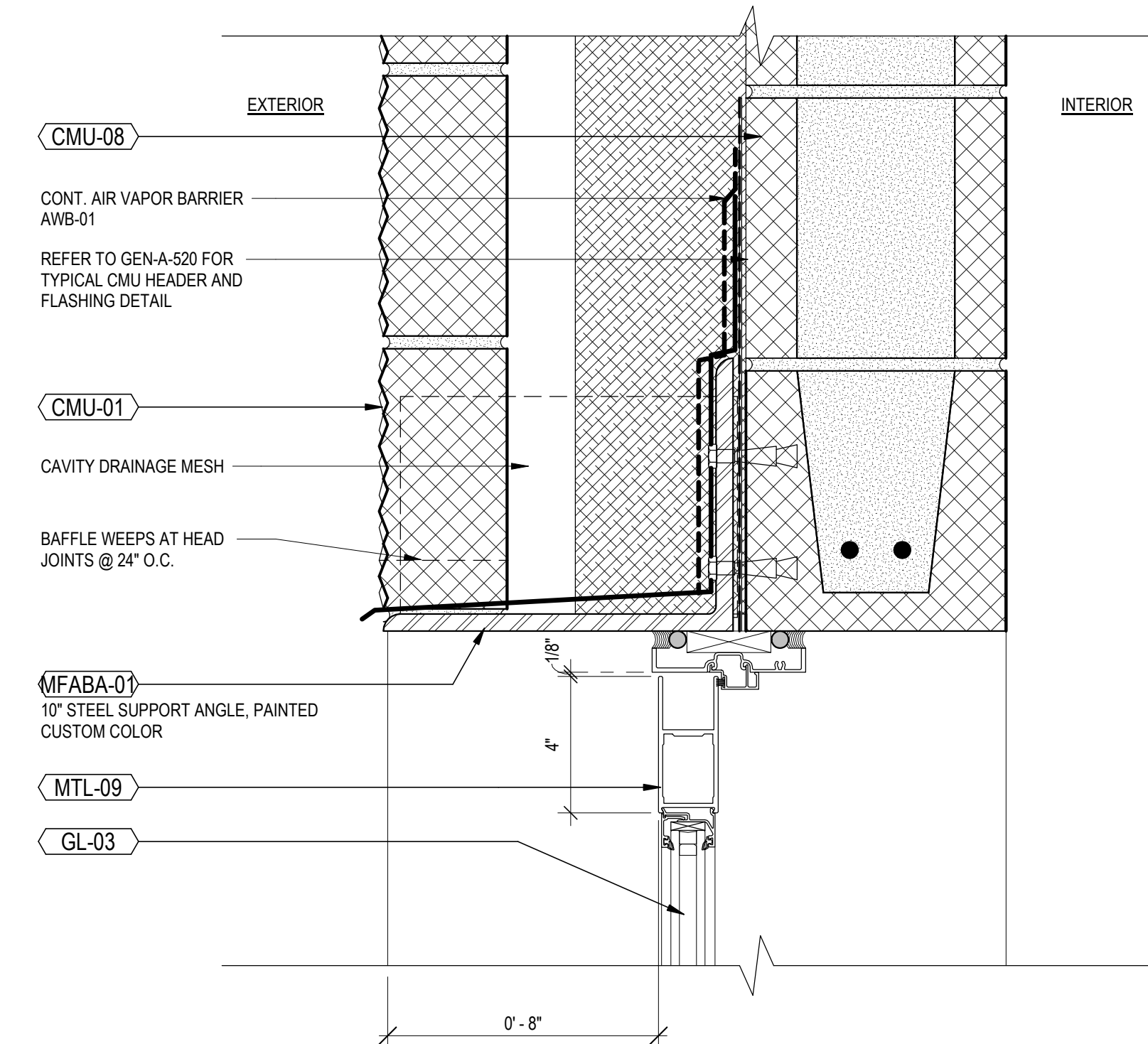

8 EXT DETAILS - STOREFRONT DOOR HEAD
SCALE: 3" = 1'-0"

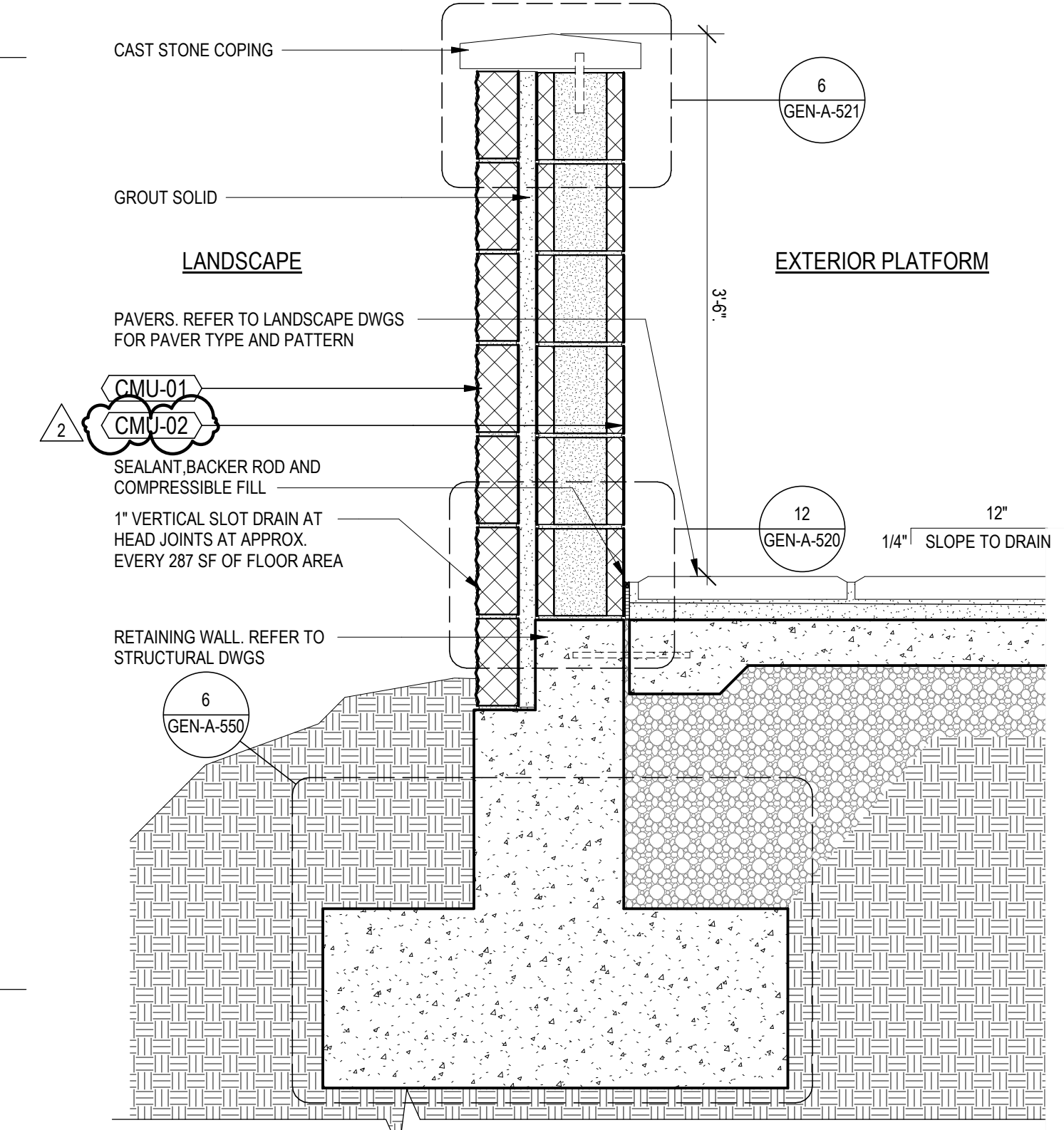

5 SITE WALL
SCALE: 1" = 1'-0"

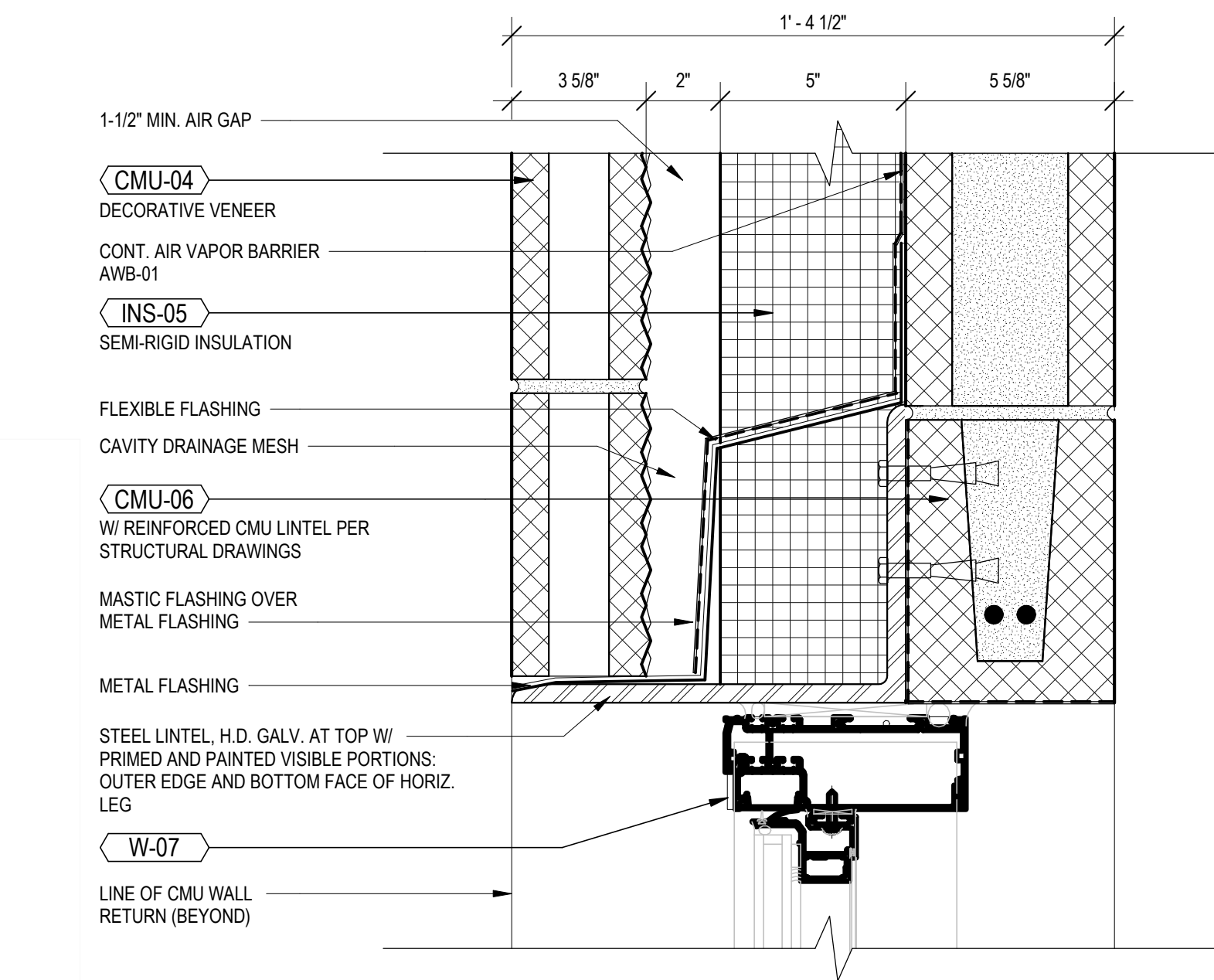

2 KENNEL WINDOW HEAD
SCALE: 3" = 1'-0"

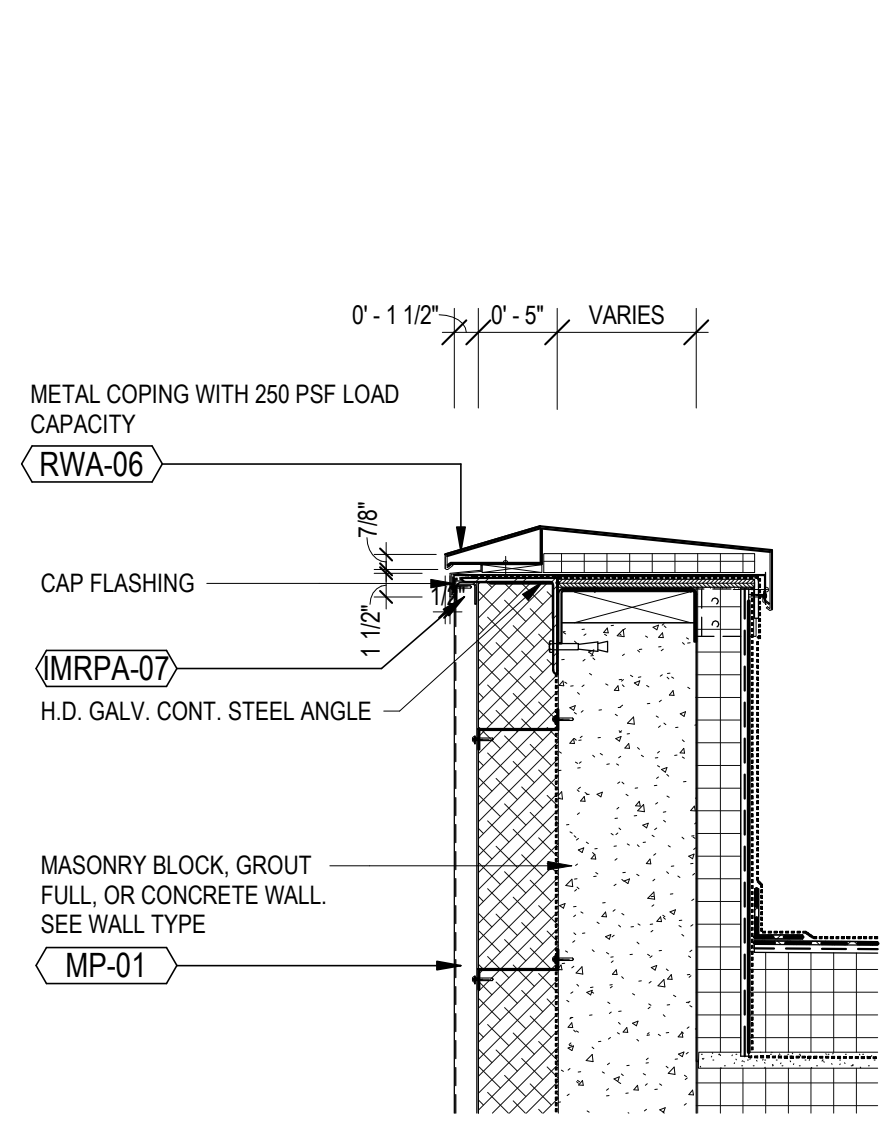

10 MTL PNL COPING
SCALE: 1" = 1'-0"

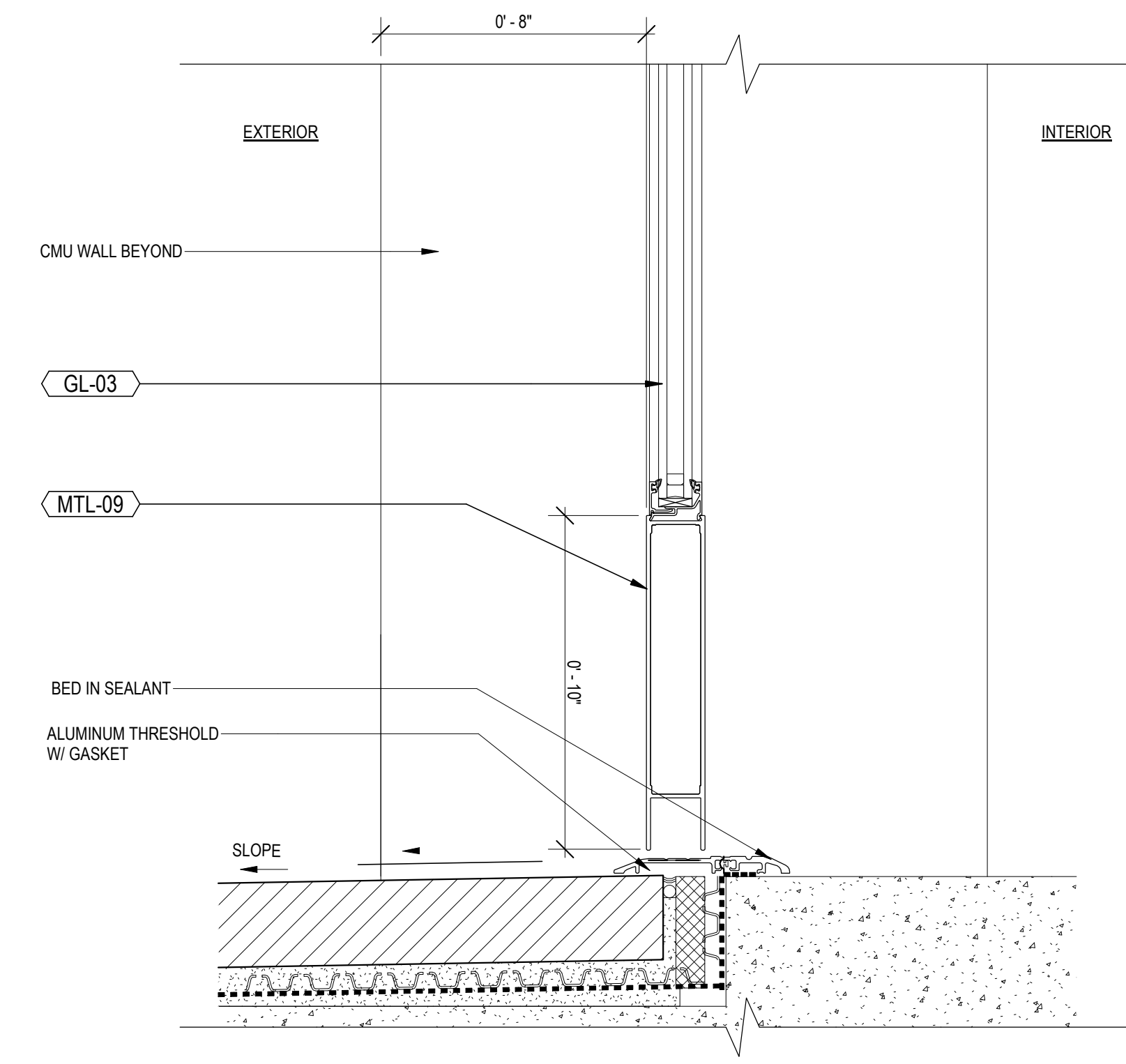

7 EXT DETAILS - STOREFRONT DOOR SILL
SCALE: 3" = 1'-0"

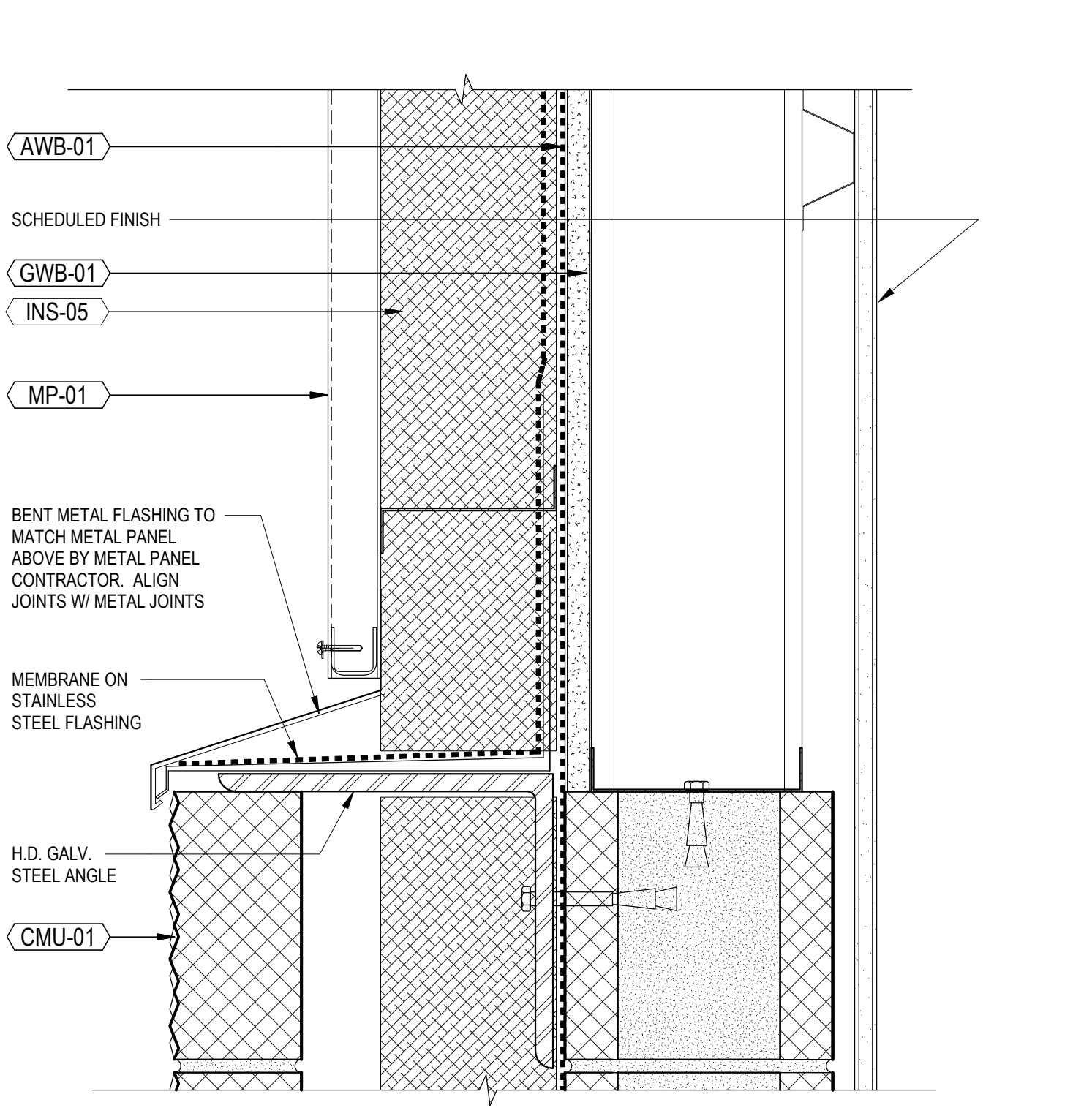

4 MTL PANEL BOTTOM - ON MTL STUD
SCALE: 3" = 1'-0"

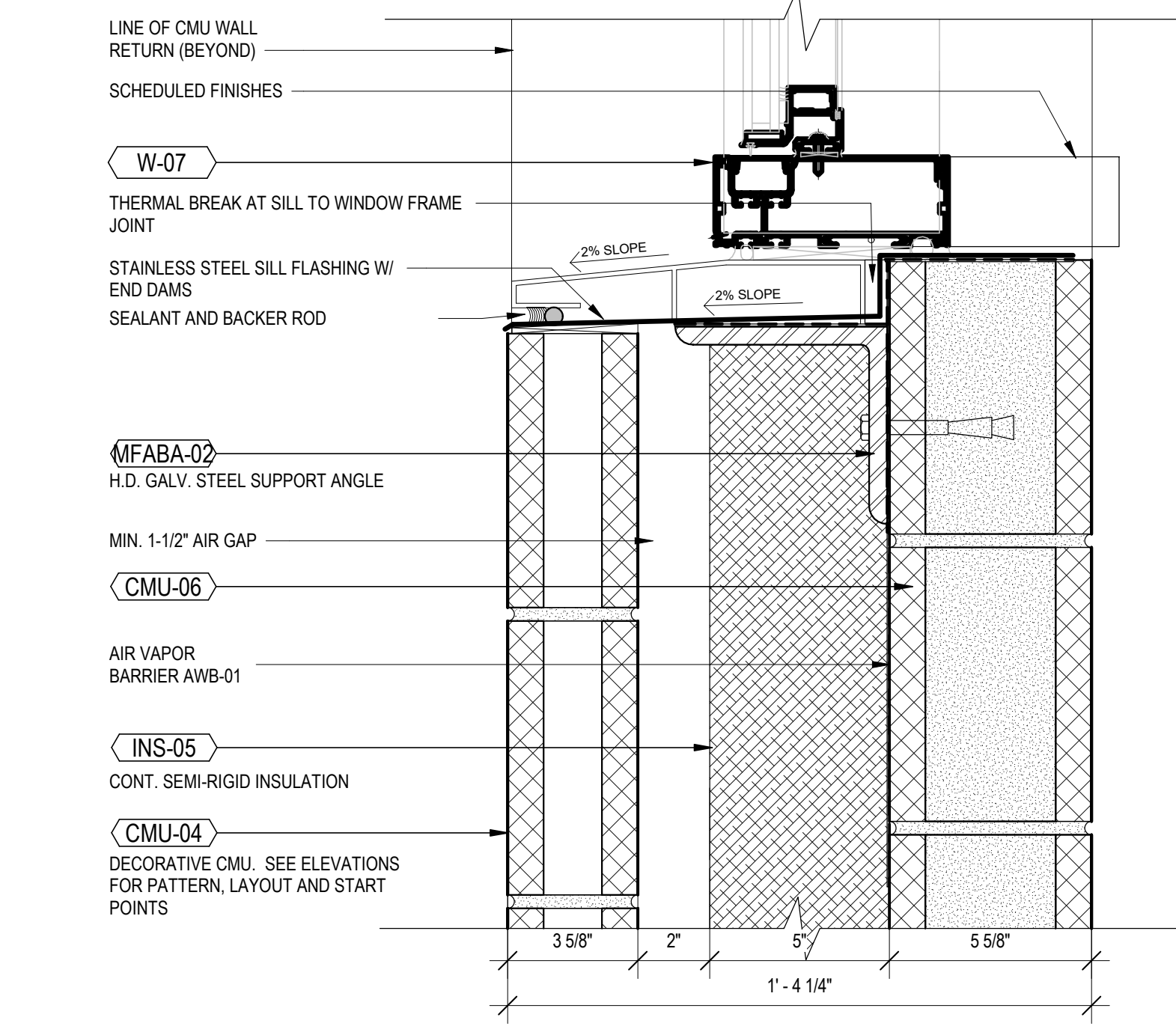

1 KENNEL WINDOW SILL
SCALE: 3" = 1'-0"

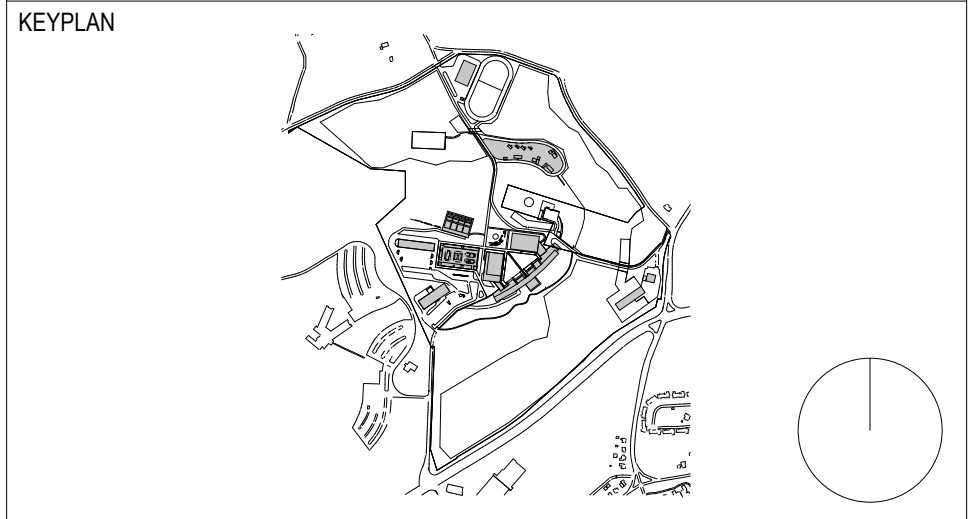

NO.	DATE	DESCRIPTION	NO.	DATE	DESCRIPTION
2	30 JUNE 2023	ADDENDUM 29			
1	19 MAY 2023	ISSUED FOR BID			

RECORD REVISIONS	
	SEAL

SIGNATURE _____ DATE _____

ARCHITECT

SOM
Skidmore, Owings & Merrill LLP
250 Greenwich St, New York, 10007

COMMONWEALTH OF PENNSYLVANIA
DEPARTMENT OF GENERAL SERVICES
HARRISBURG, PENNSYLVANIA

D.G.S. PROJECT No. C-0211-0005 PHASE 5

Pennsylvania State Police Academy
Core Buildings, BESO & Sitework
PENNSYLVANIA STATE POLICE
HERSHEY, DAUPHIN COUNTY, PA

VERIFY SCALE			
BAR IS ONE (1) INCH LONG	ON ORIGINAL DRAWING:	1	
IF BAR IS NOT ONE (1) INCH LONG, ADJUST SCALE ACCORDINGLY			

CONTRACTOR SHALL FIELD VERIFY ALL DIMENSIONS. VARIANCE FROM CONTRACT DOCUMENTS NOT PERMITTED WITHOUT PROFESSIONAL & BUREAU OF CONSTRUCTION APPROVAL.

SHEET No.	DATE	SCALE
GEN-A-521	SEPT 2022	AS NOTED

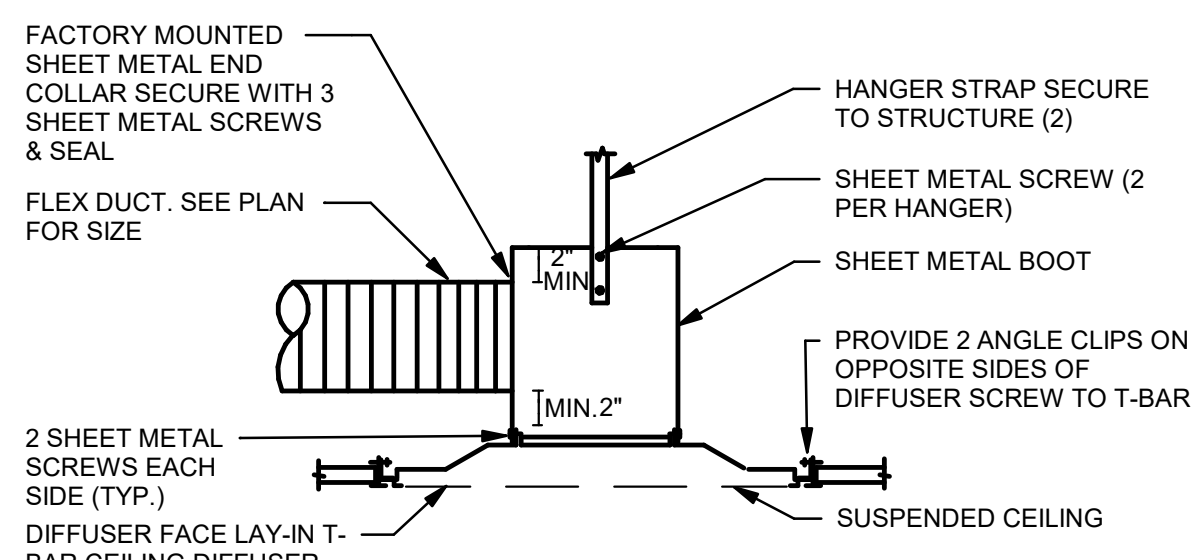

NOTES:
 A. USE THIS DETAIL WHERE 1.5 x RADIUS ON FLEXIBLE DUCT IS NOT POSSIBLE.
 B. SIMILAR FOR GYP BOARD CEILING.

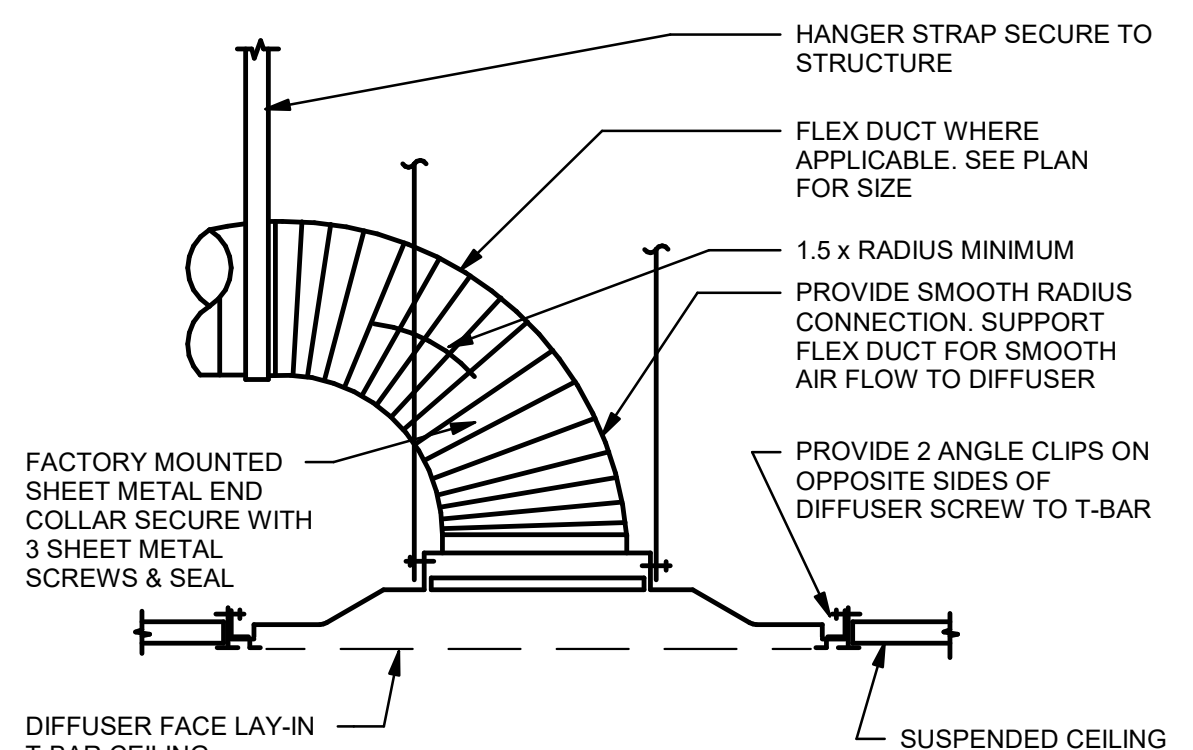

NOTES:
 A. USE MOUNTING DETAIL WHERE SPACE PERMITS. WHERE SPACE DOES NOT PERMIT FOLLOW DETAIL ABOVE.
 B. SIMILAR FOR GYP BOARD, SPLINE CEILING.

1 CEILING DIFFUSER CONNECTION DETAIL
 NO SCALE

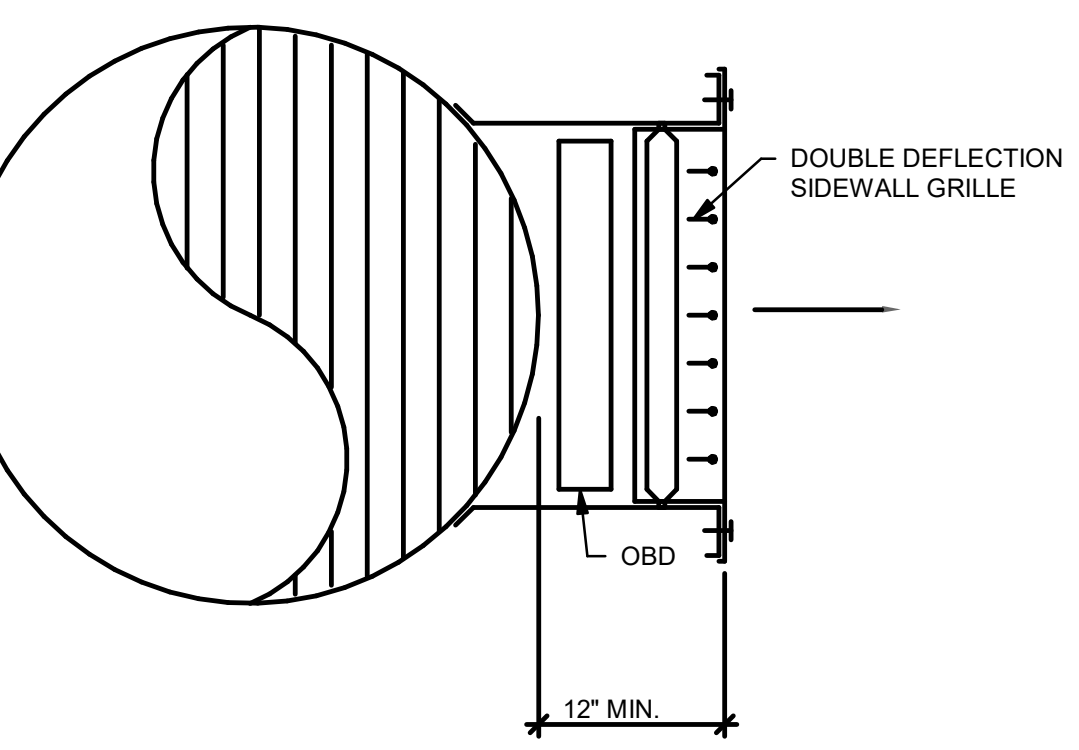

2 DUCT MOUNTED DIFFUSER CONNECTION DETAIL
 NO SCALE

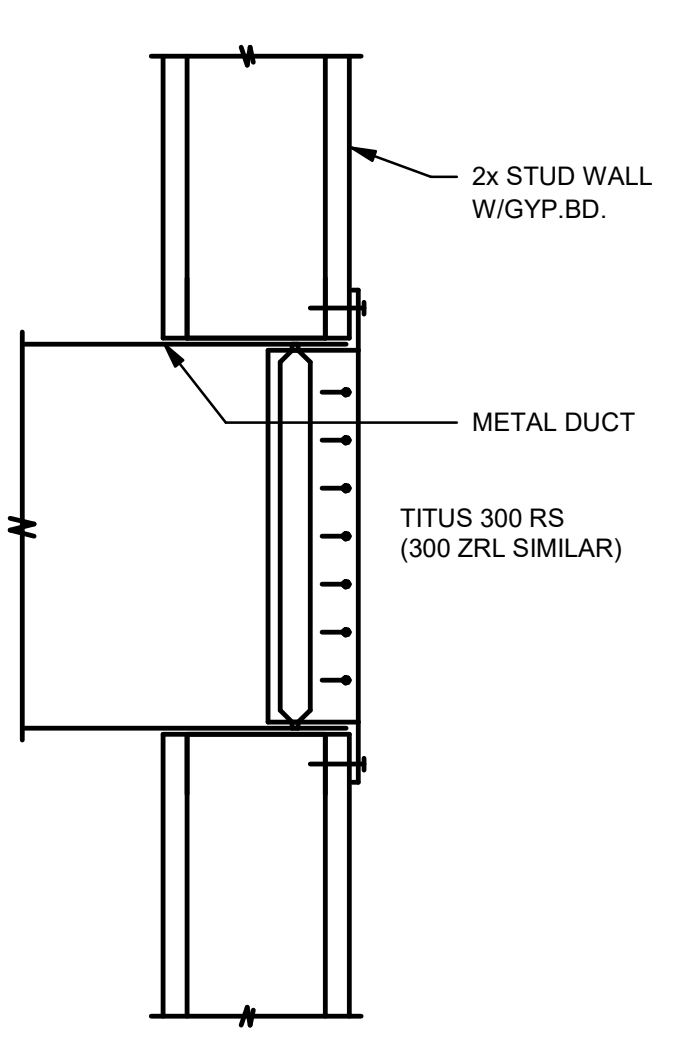

3 SIDEWALL DIFFUSER CONNECTION DETAIL
 NO SCALE

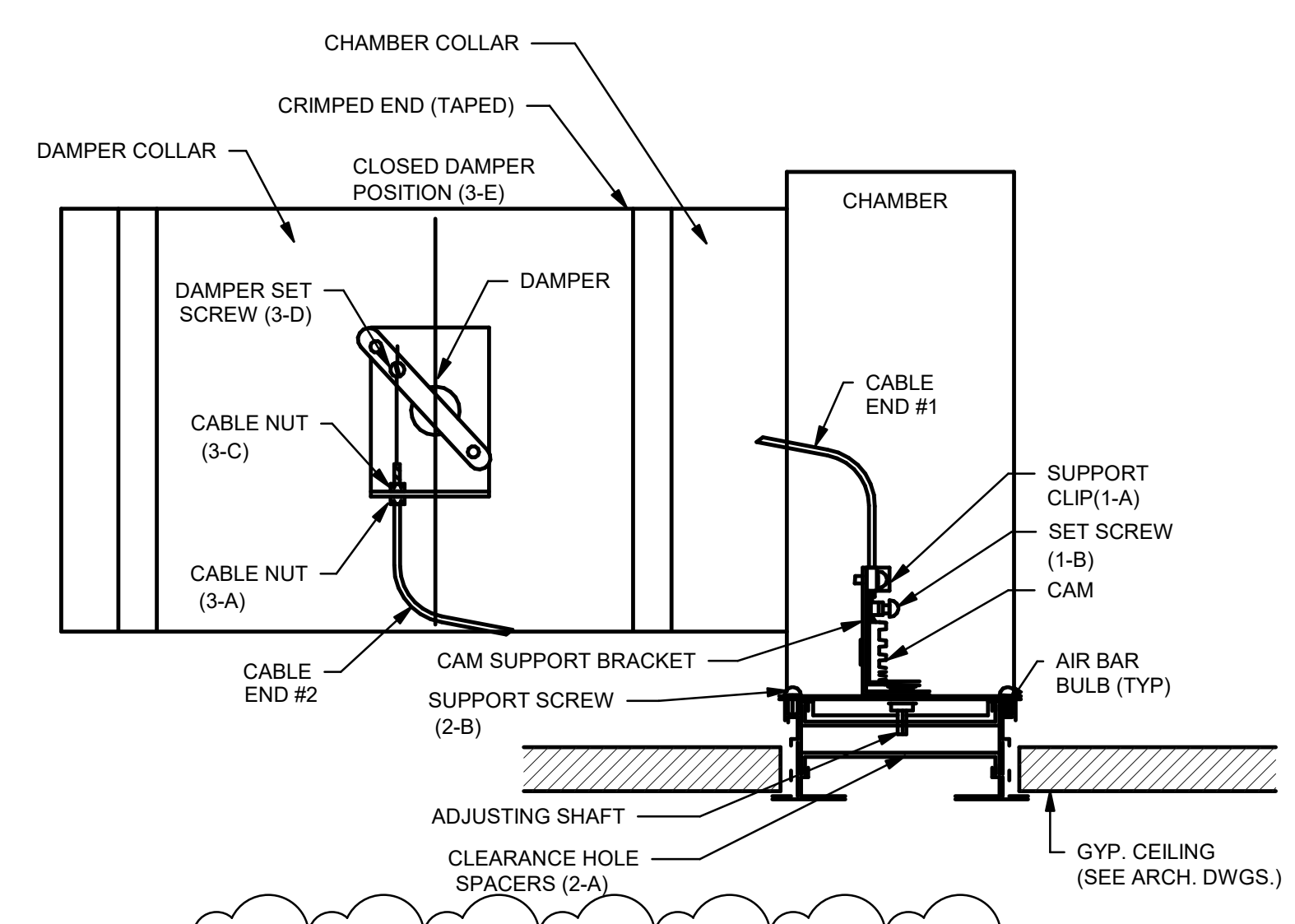

NOTES:
 A. MECHANICAL CONTRACTOR TO PROVIDE AND INSTALL PLENUM BOX.

4 SLOT WITH INTEGRAL VOLUME DAMPER
 NO SCALE

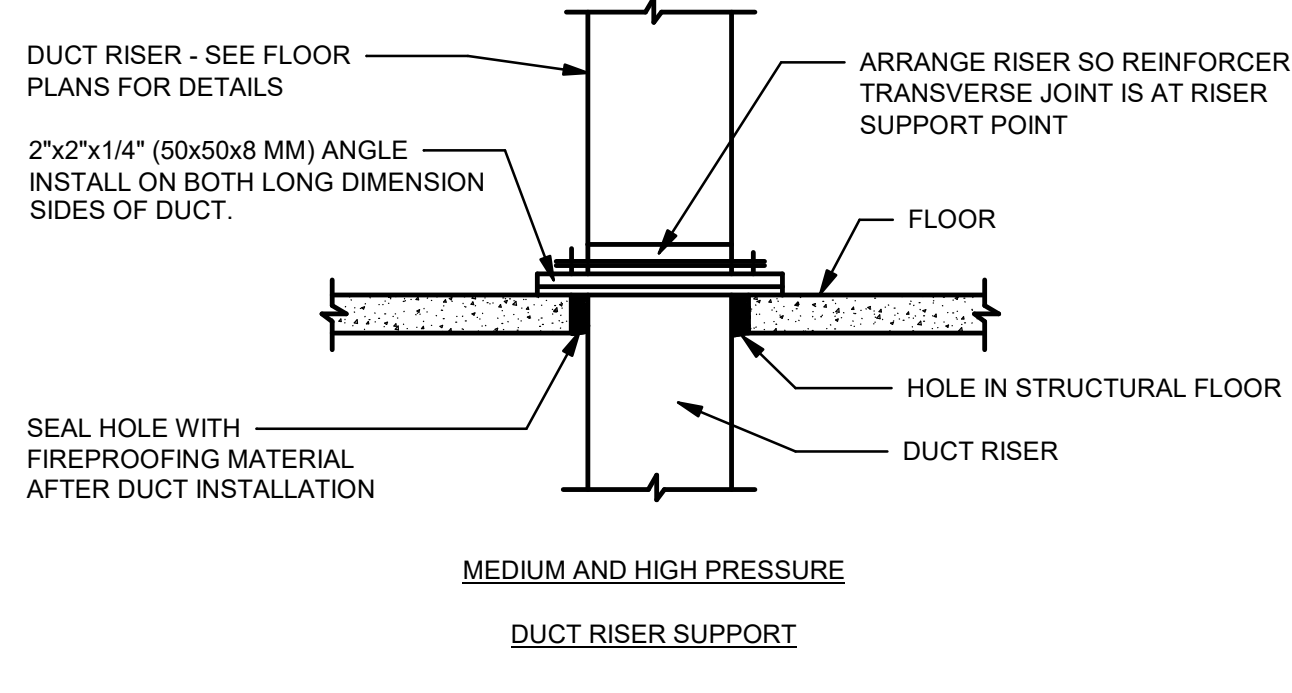
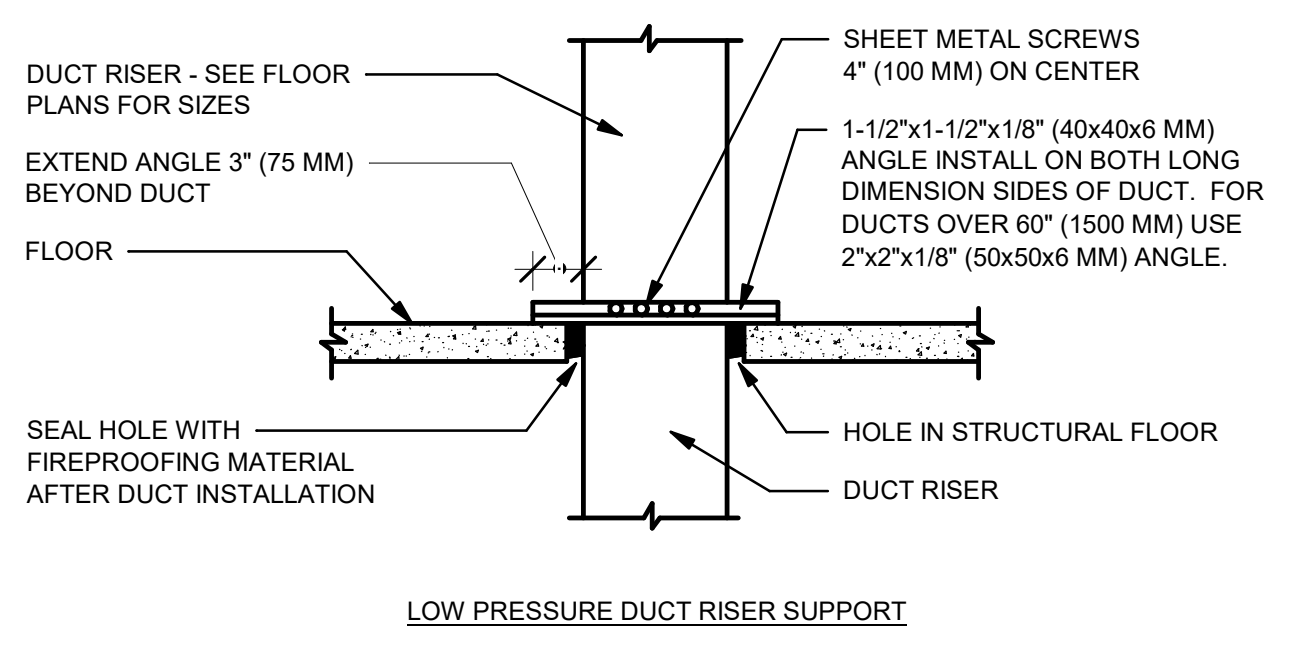

NOTE:
 1. ALL DUCT WORK RISERS WHICH ARE RUN EXPOSED, SUCH AS THRU ATTIC FLOORS AND FAN ROOM FLOORS SHALL BE PROVIDED WITH A 3\"/>

DESIGNER'S NOTE:
 1. INDICATE ON DRAWING WHICH DUCTS ARE LOW PRESSURE (2\"/>

5 DUCT RISER SUPPORT
 NO SCALE

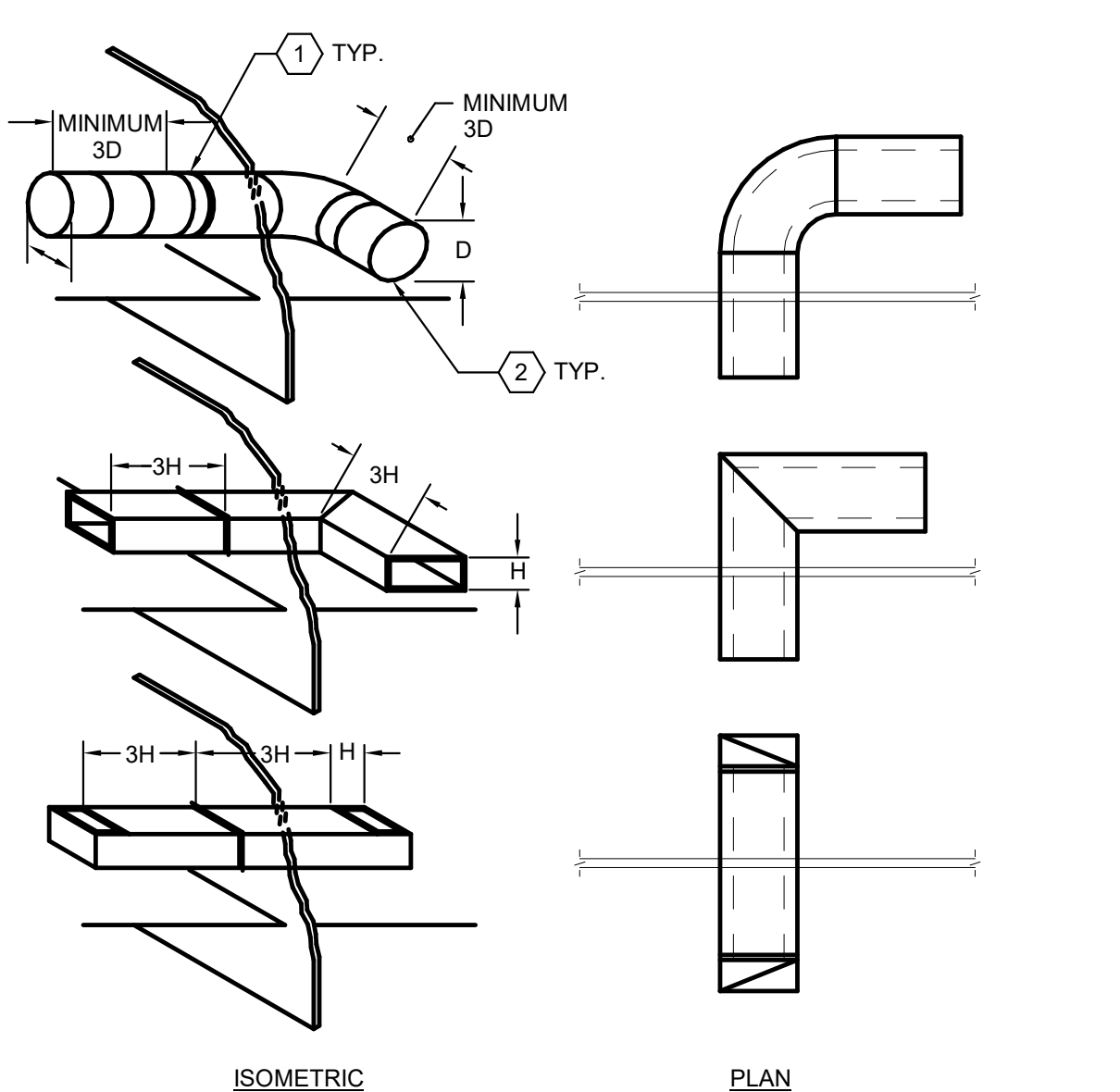

NOTE:
 A. SHALL BE USED ON ALL DUCTS UPSTREAM OF TERMINAL UNITS.

6 ACOUSTIC AIR TRANSFER DUCT DETAILS
 NO SCALE

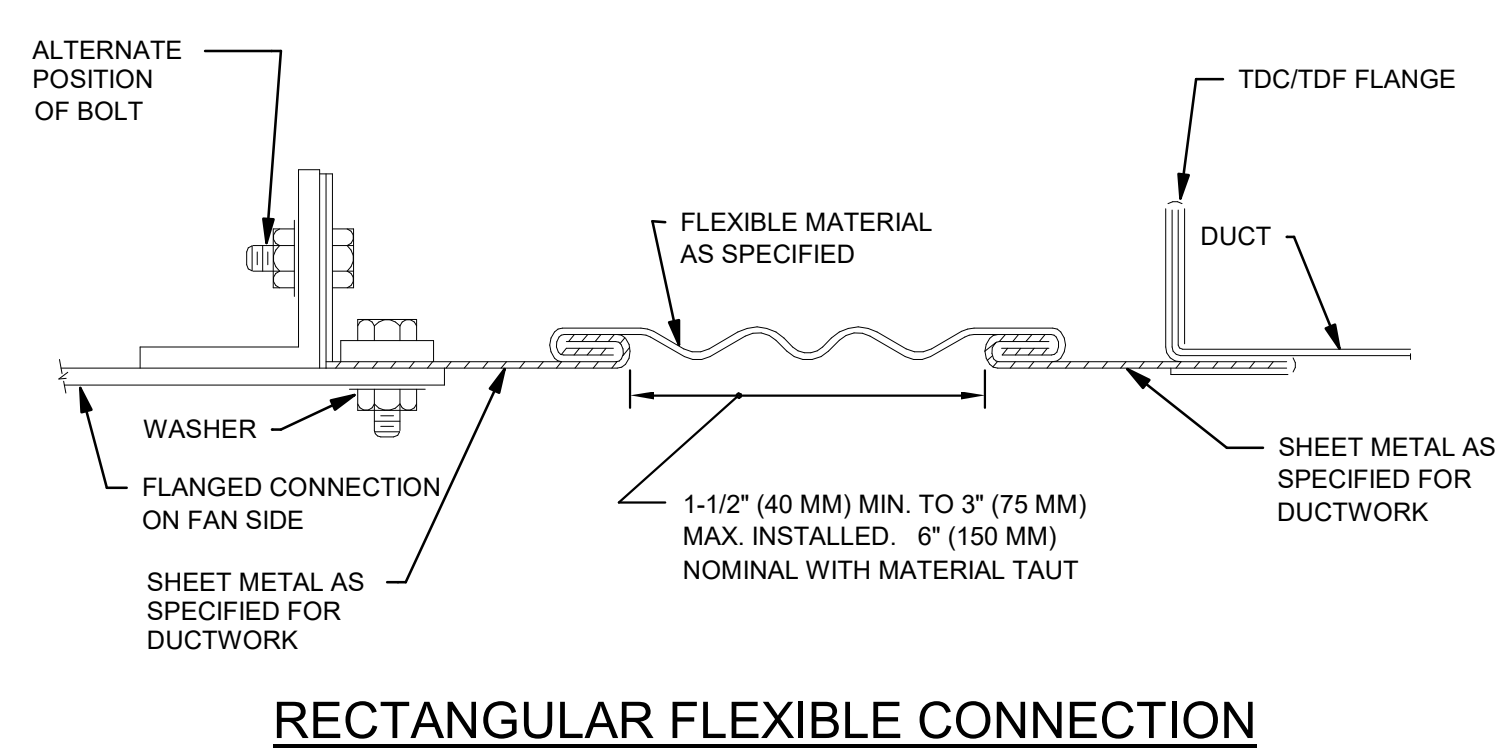

RECTANGULAR FLEXIBLE CONNECTION

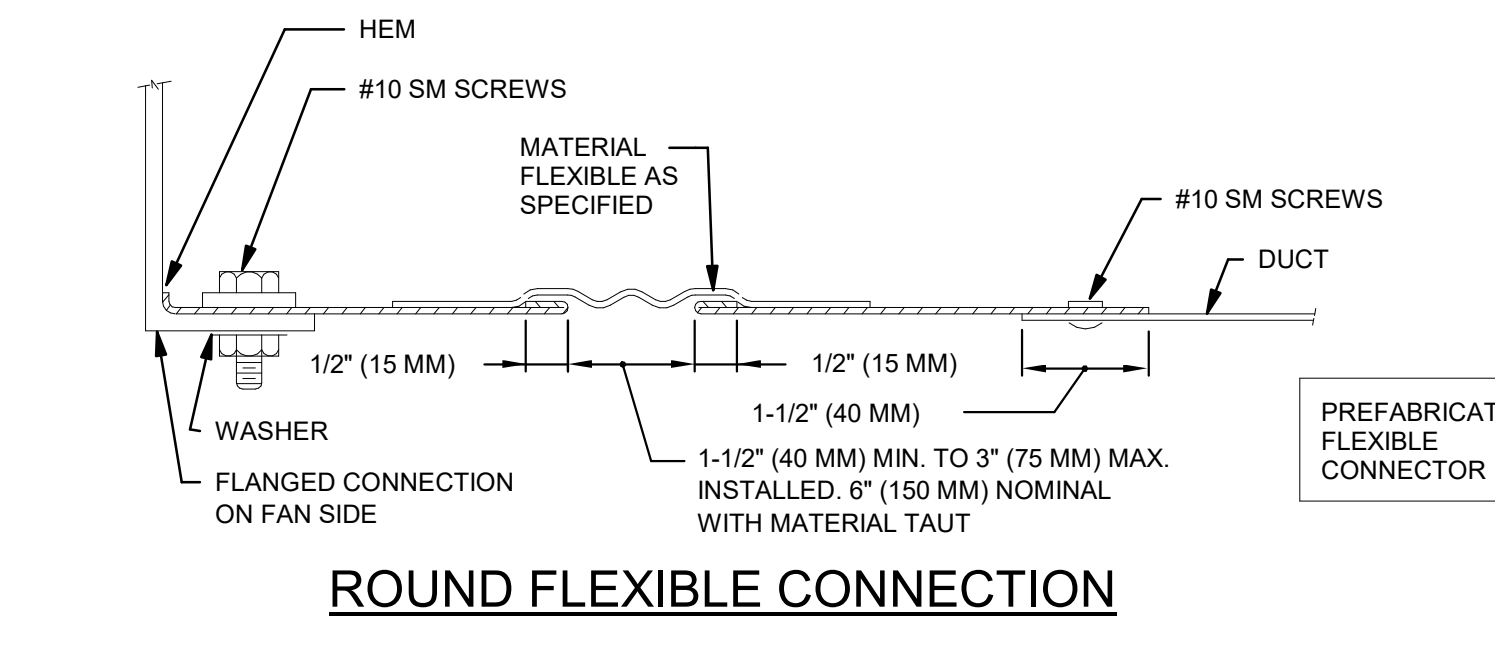

ROUND FLEXIBLE CONNECTION

7 DUCT SUPPORT DETAIL
 NO SCALE

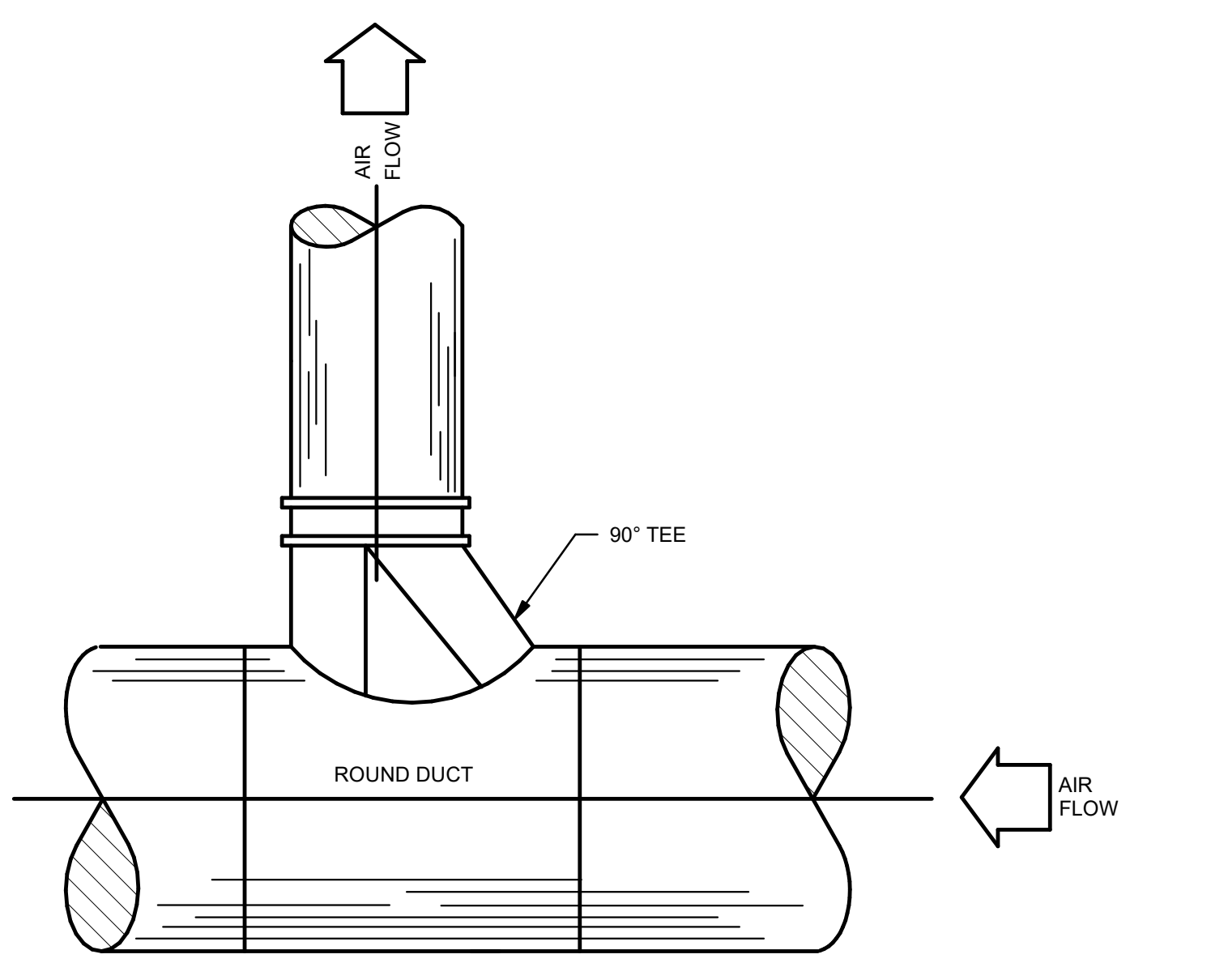

8 LOW LOSS FITTING ROUND TO ROUND
 NO SCALE

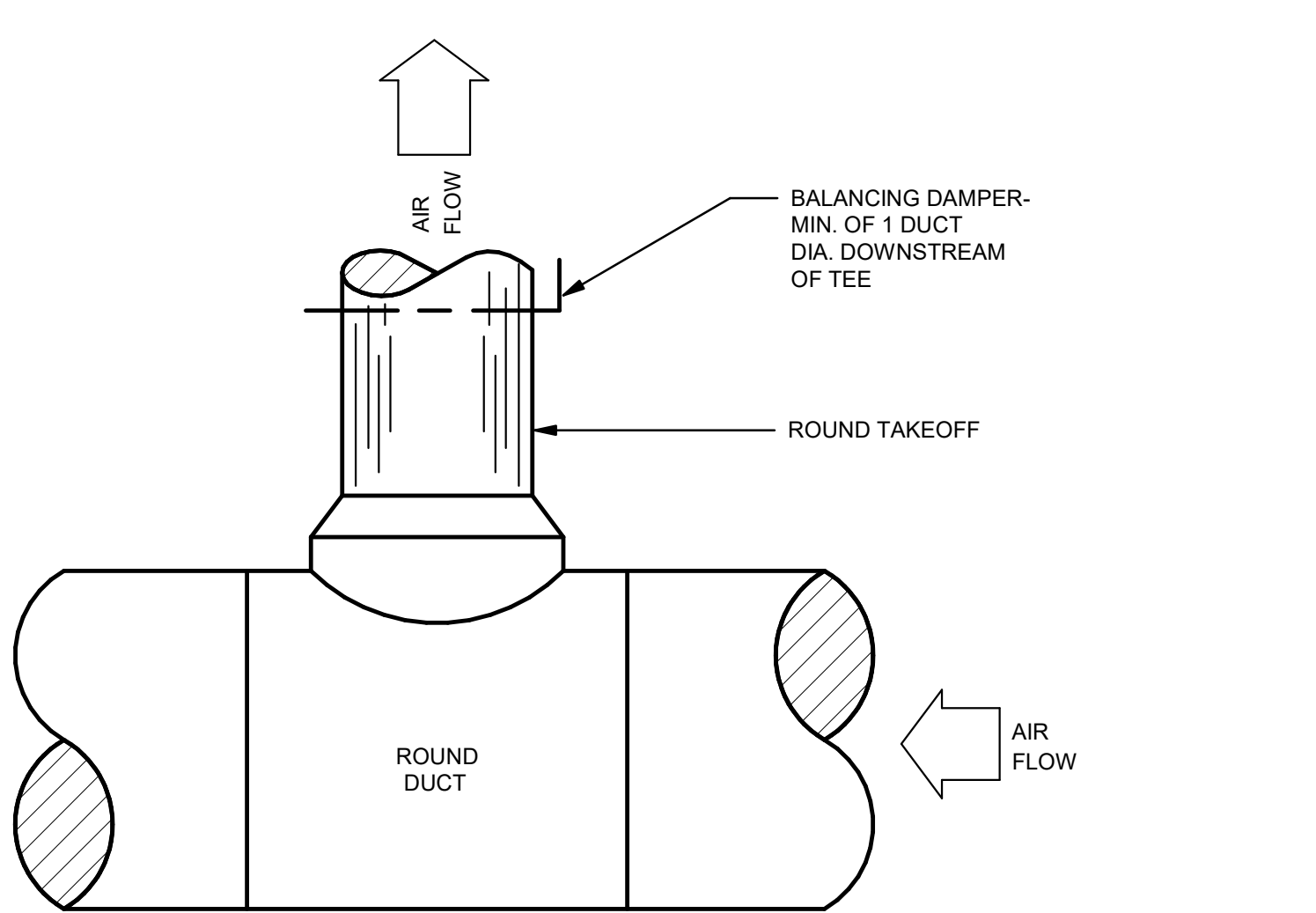

NOTE:
 A. SHALL BE USED ON ALL DUCTS UPSTREAM OF TERMINAL UNITS.

9 MEDIUM PRESSURE DUCT TAP - CONICAL TEE
 NO SCALE

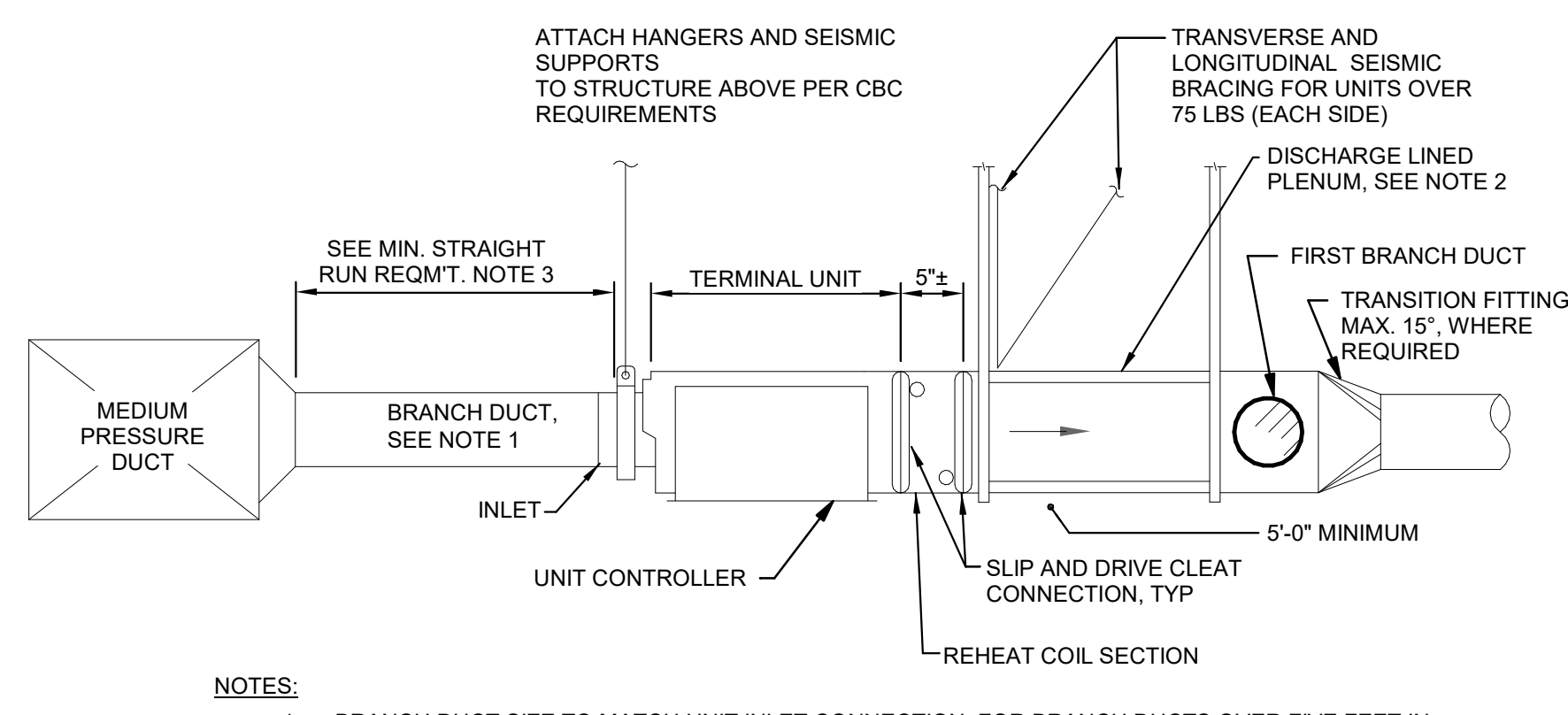

NOTES:
 1. BRANCH DUCT SIZE TO MATCH UNIT INLET CONNECTION. FOR BRANCH DUCTS OVER FIVE FEET IN LENGTH, INCREASE BRANCH DUCT ONE SIZE AND PROVIDE TRANSITION IMMEDIATELY UPSTREAM OF MINIMUM STRAIGHT DUCT RUN.
 2. MINIMUM 5'-0\"/>

10 TYPICAL TERMINAL UNIT DUCTING (VAV OR CAV)
 NO SCALE

TACTICAL TRAINING DESIGN

Tactical Design North, Inc.
 231 E. Buffalo St #502, Milwaukee, WI 53202

LOCAL ARCHITECT

Jacobs Wyper Architects
 1232 Chancellor St, Philadelphia, PA 19107

STRUCTURAL ENGINEER

Skidmore, Owings & Merrill LLP
 250 Greenwich St, New York, NY 10007

ELECTRICAL, PLUMBING, FIRE PROTECTION, FIRE ALARM ENGINEER

A & J Consulting Engineering Services, P.C.
 164 Brighton Rd, Clifton, NJ 07012

MECHANICAL AVIT ENGINEER

Interface Engineering, Inc.
 2000 M Street NW, Suite 270, Washington, DC 20036

ACOUSTICAL ENGINEER

Cerami
 1001 Ave of the Americas, 4th Floor, New York, NY 10018

CODE CONSULTING

CCI
 215 W 40th St, 10th Floor, New York, NY 10018

CIVIL ENGINEER

Langan
 1818 Market St #3300, Philadelphia, PA 19103

VERTICAL TRANSPORT

Michael Blades & Associates Ltd.
 5409 Rapihan Ct, Lothian, MD 20711

SIGNAGE CONSULTANT

Patricia Hord Graphik Design
 119 S. St. Asaph St, Alexandria, VA 22314

LANDSCAPE

Lee and Associates, Inc.
 638 I Street NW, Washington, DC 20001

LIGHTING

MCLA
 1000 Potomac St NW, Suite 121, Washington, DC 20007

FOOD SERVICE

Hopkins Foodservice Specialists, Inc.
 7906 MacArthur Blvd, Suite 100, Cabin John, MD 20818

POOL DESIGN

AQUA Design International
 7536 N. La Cholla Blvd, Tucson, AZ 85741

KEYPLAN

NO.	DATE	DESCRIPTION	NO.	DATE	DESCRIPTION
3	29 JUN 2023	ADDENDUM 29			
2	19 MAY 2023	ISSUED FOR BID			

RECORD REVISIONS

SEAL

SIGNATURE _____ DATE _____

ARCHITECT

SOM
 Skidmore, Owings & Merrill LLP
 250 Greenwich St, New York, 10007

COMMONWEALTH OF PENNSYLVANIA
 DEPARTMENT OF GENERAL SERVICES
 HARRISBURG, PENNSYLVANIA

D.G.S. PROJECT No. **C-0211-0005 PHASE 5**

Pennsylvania State Police Academy
 Core Buildings, BESO & Sitework
 PENNSYLVANIA STATE POLICE
 HERSHEY, DAUPHIN COUNTY, PA

VERIFY SCALE

BAR IS ONE (1) INCH LONG ON ORIGINAL DRAWING: 0 1

IF BAR IS NOT ONE (1) INCH LONG, ADJUST SCALE ACCORDINGLY

CONTRACTOR SHALL FIELD VERIFY ALL DIMENSIONS. VARIANCE FROM CONTRACT DOCUMENTS NOT PERMITTED WITHOUT PROFESSIONAL & BUREAU OF CONSTRUCTION APPROVAL.

SHEET No. **GYM-M-700**

DRAWN BY	CHECKED BY	DATE	SCALE
Author	Checker	FEB. 2022	AS NOTED

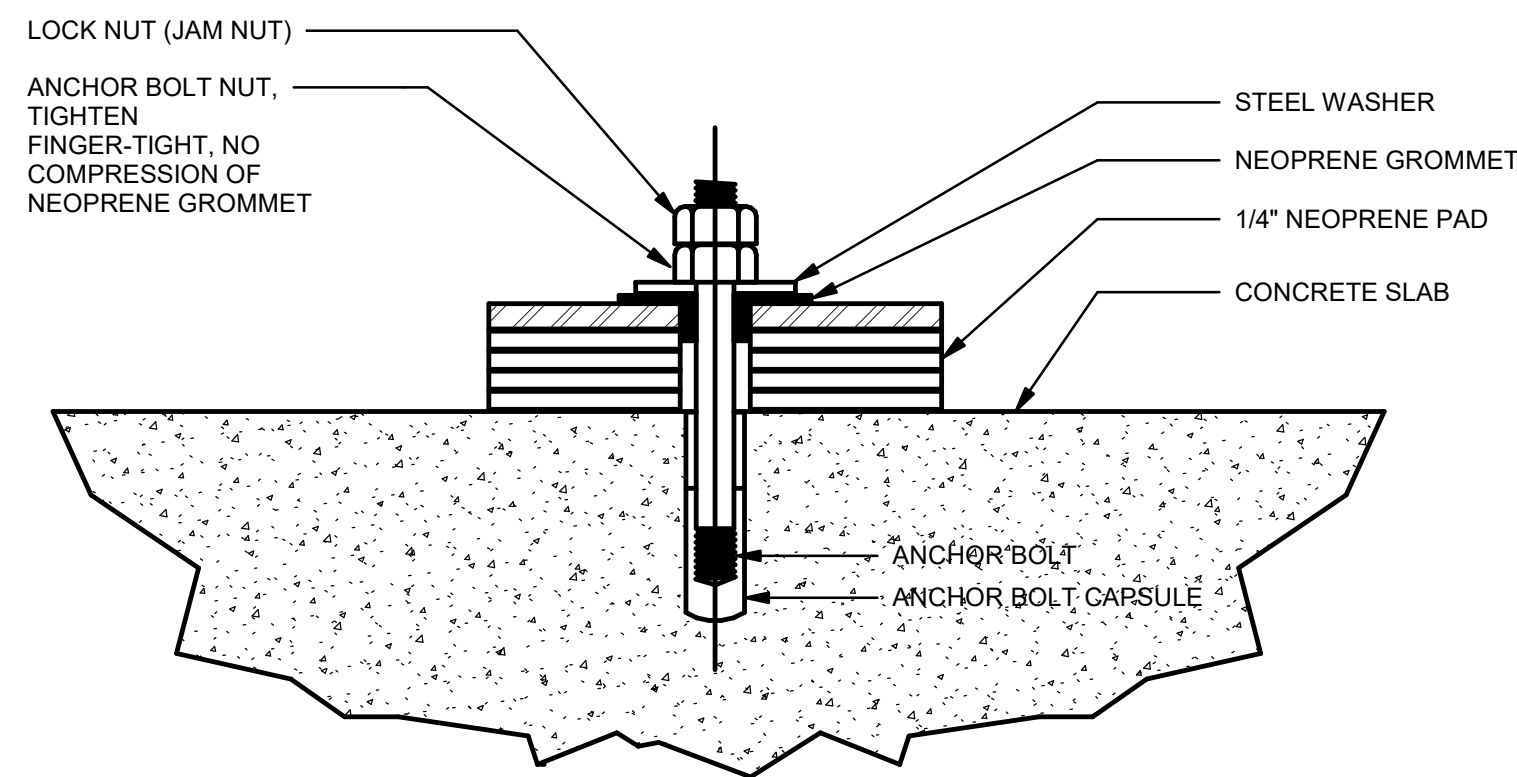

1 EQUIPMENT ANCHORAGE

NO SCALE

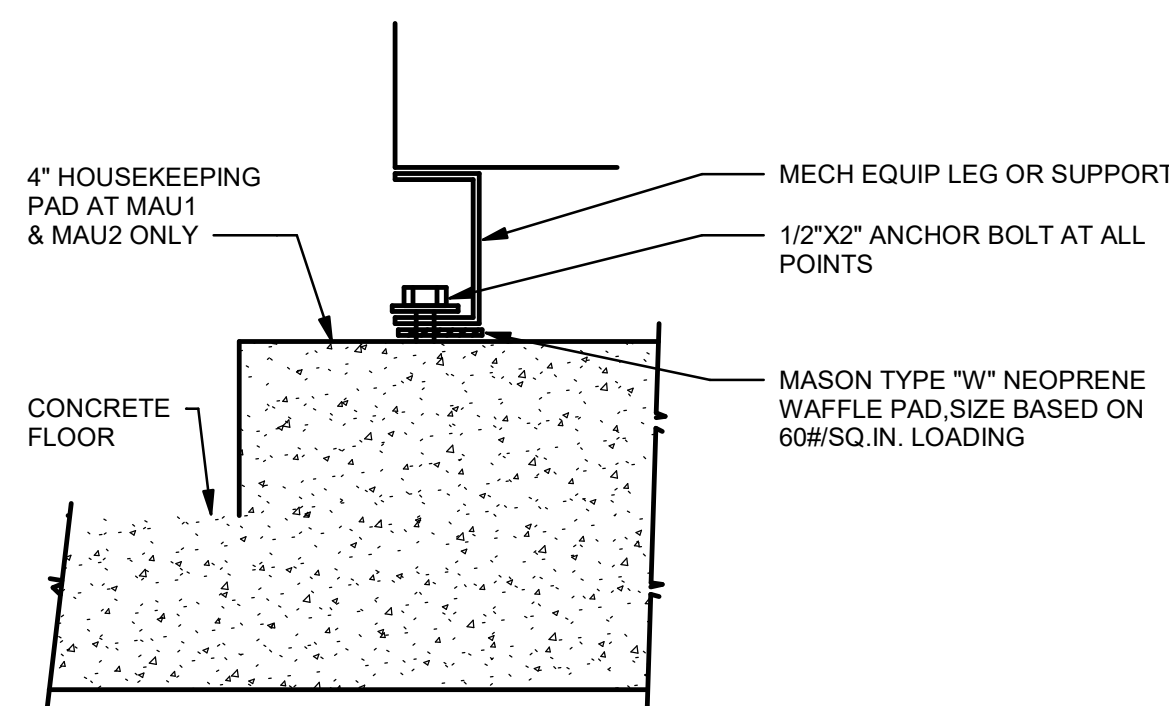

2 EQUIPMENT ATTACHMENT W/O ISOLATORS

NO SCALE

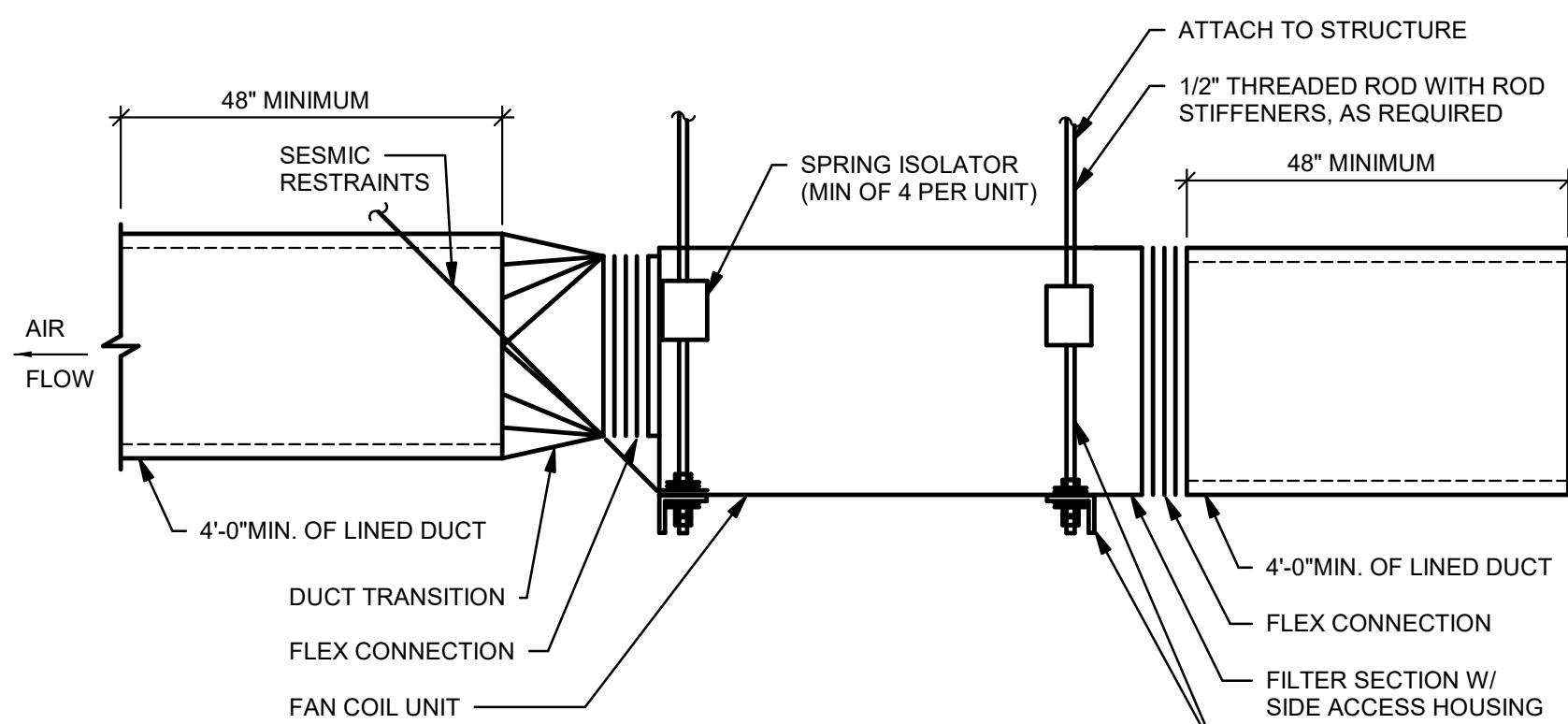

NOTE:
1. PROVIDE SEISMIC BRACING AT ALL FAN COILS. SEE SPECIFICATIONS FOR SEISMIC DESIGN CRITERIA.

3 FAN COIL UNIT HANGING DETAIL (FC-x)

NO SCALE

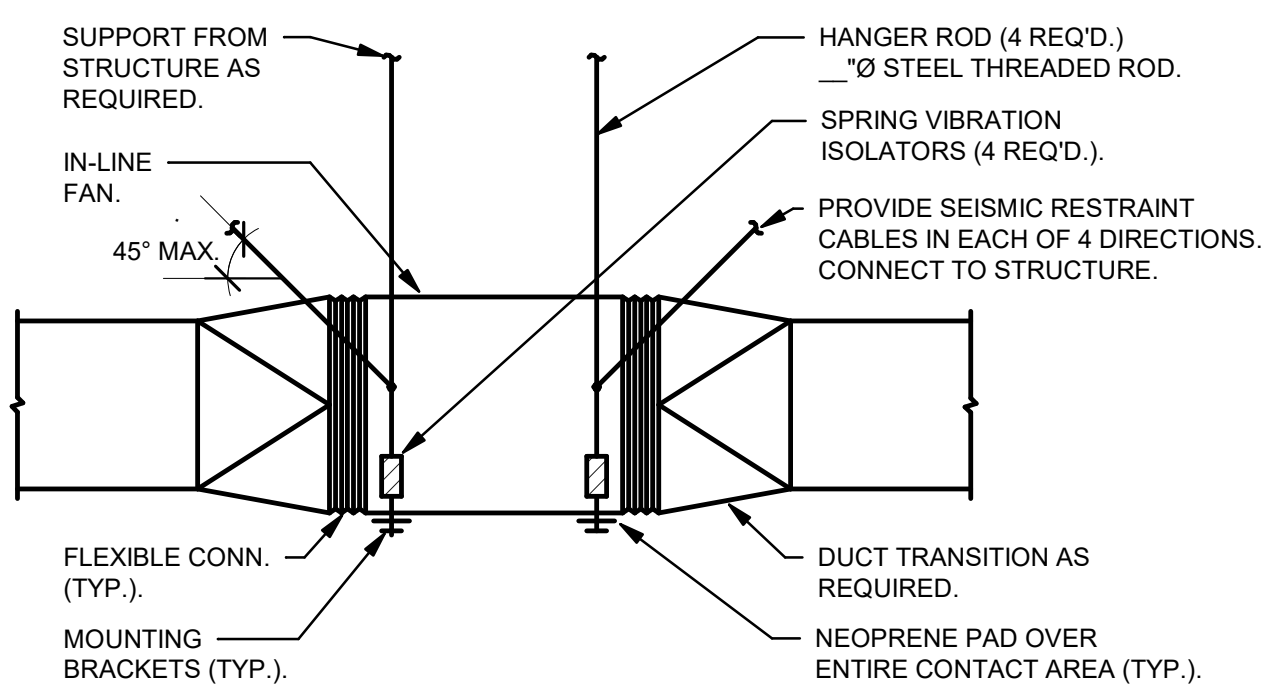

4 IN-LINE FAN

NO SCALE

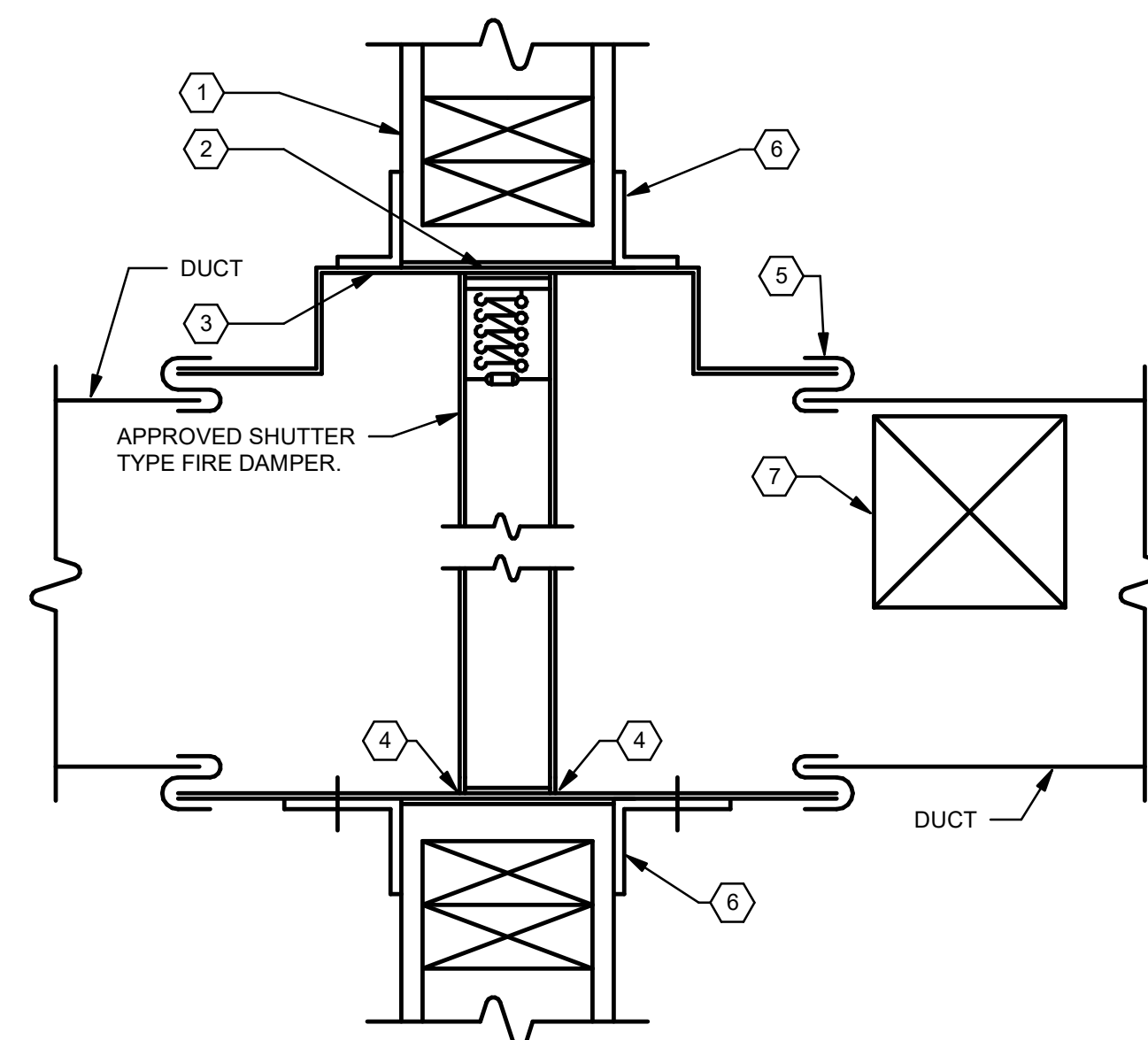

5 FIRE DAMPER

NO SCALE

- NOTES:
- 1 FIRE RATED PARTITION. COORDINATE WITH ARCHITECTURAL FOR FRAMING AND FIRE RATED LINING REQUIREMENTS.
 - 2 COORDINATE PARTITION OPENING, 1/8\"/>

GENERAL NOTES:
DETAIL INDICATES REQUIREMENTS FOR STANDARD FRAME INSTALLATION. REFERENCE "SMACNA FIRE, SMOKE AND RADIATION DAMPER INSTALLATION GUIDE" FOR OTHER CONFIGURATION REQUIREMENTS. COMPLY FULLY WITH ABOVE MENTIONED AND ALSO AHJ REQUIREMENTS IN ALL CASES.

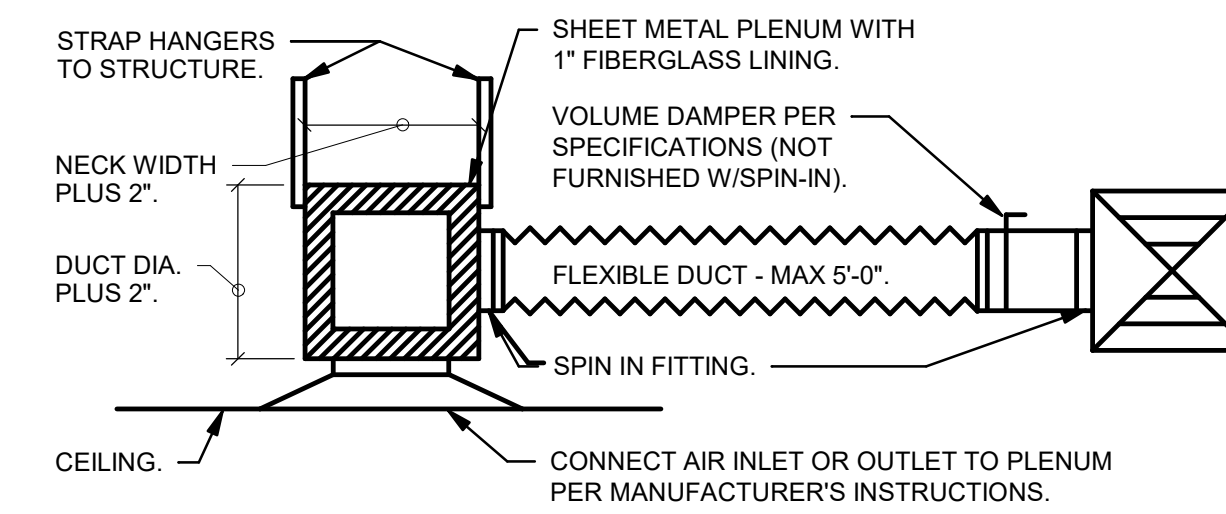

9 AIR INLET OR OUTLET SQUARE NECK

NO SCALE

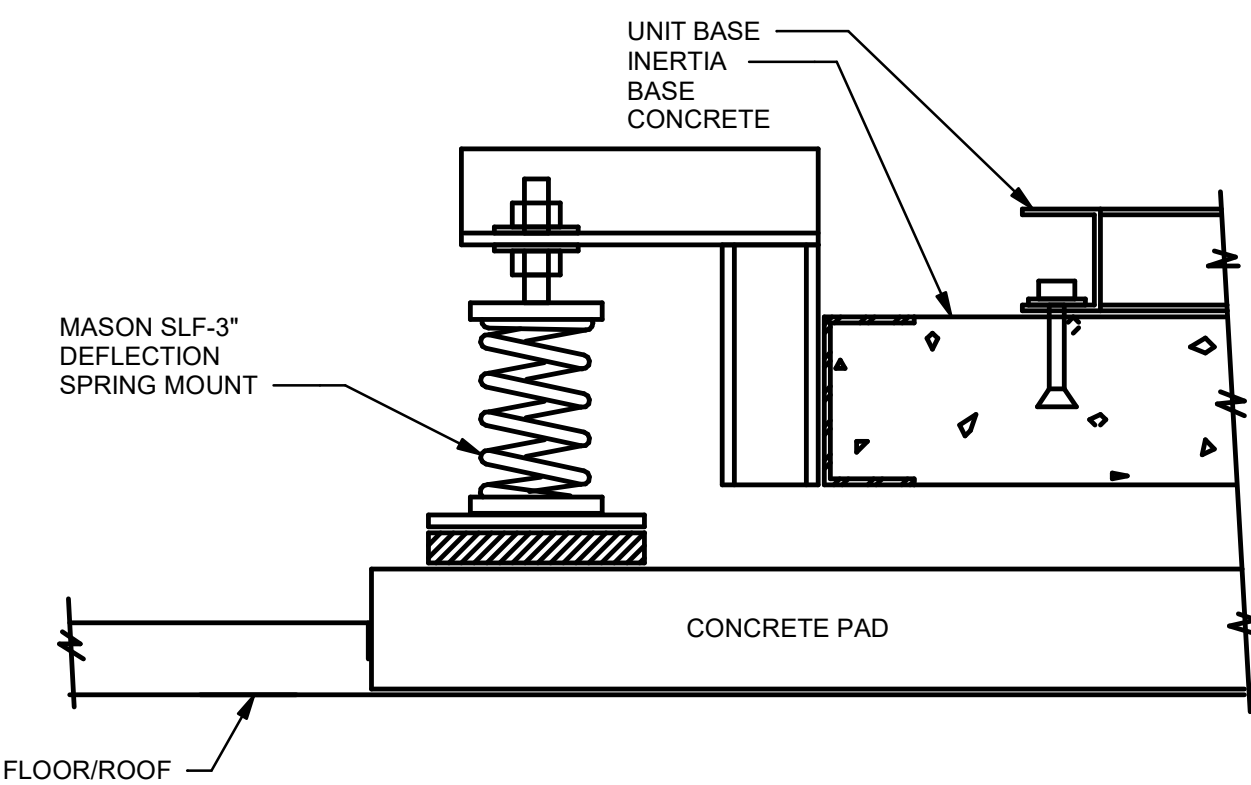

NOTE:
PROVIDE MASON Z-1225 SEISMIC SNUBBER - MIN 4

6 INERTIA BASE SUPPORT DETAIL

NO SCALE

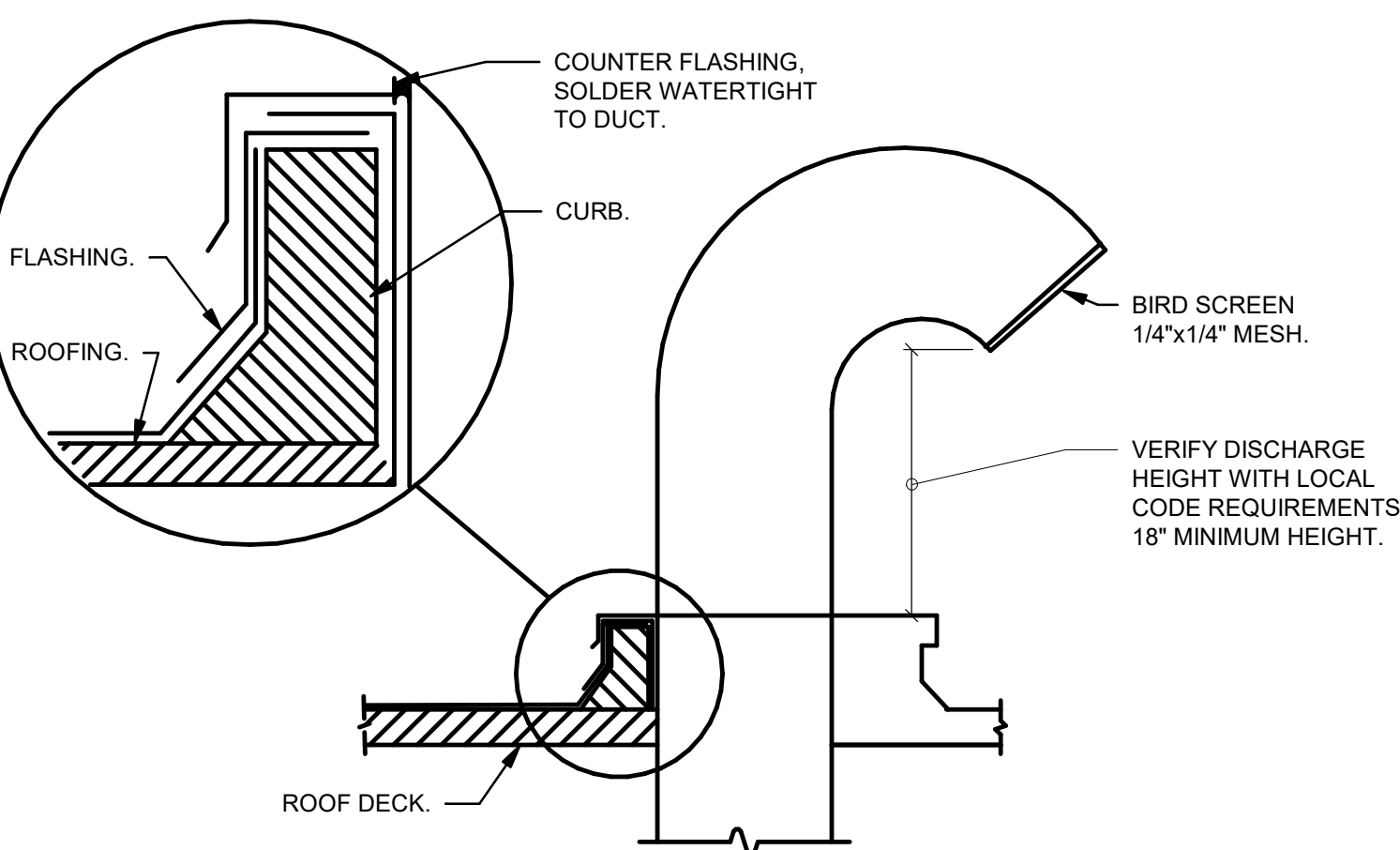

7 GOOSENECK - RECTANGULAR DUCT

NO SCALE

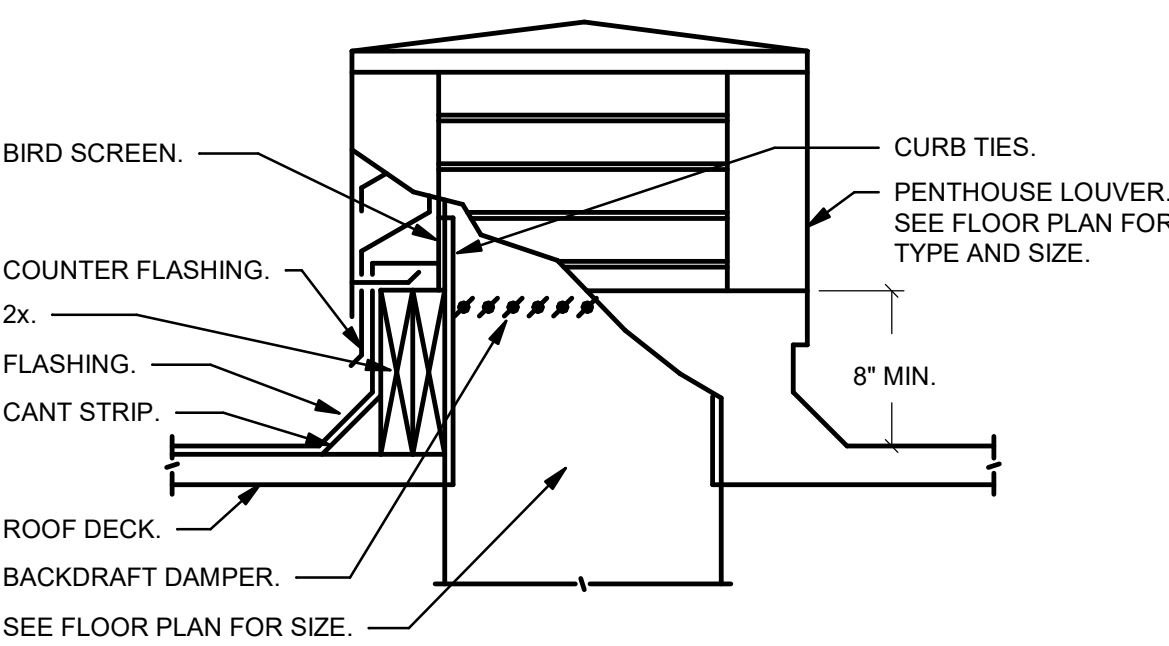

8 ROOF VENT CURB

NO SCALE

TACTICAL TRAINING DESIGN

Tactical Design North, Inc.
231 E. Buffalo St #502, Milwaukee, WI 53202

LOCAL ARCHITECT

Jacobs Wyper Architects
1232 Chancellor St, Philadelphia, PA 19107

STRUCTURAL ENGINEER

Skidmore, Owings & Merrill LLP
250 Greenwich St, New York, NY 10007

ELECTRICAL, PLUMBING, FIRE PROTECTION, FIRE ALARM ENGINEER

A & J Consulting Engineering Services, P.C.
164 Brighton Rd, Clifton, NJ 07012

MECHANICAL, AVIT ENGINEER

Interface Engineering, Inc.
2000 M Street NW, Suite 270, Washington, DC 20036

ACOUSTICAL ENGINEER

Cerami
1001 Ave of the Americas, 4th Floor, New York, NY 10018

CODE CONSULTING

CCI
215 W 40th St, 10th Floor, New York, NY 10018

CIVIL ENGINEER

Langan
1818 Market St #3300, Philadelphia, PA 19103

VERTICAL TRANSPORT

Michael Blades & Associates Ltd.
5409 Rapidan Ct, Lothian, MD 20711

SIGNAGE CONSULTANT

Patricia Hord Graphik Design
119 S. St. Asaph St, Alexandria, VA 22314

LANDSCAPE

Lee and Associates, Inc.
638 I Street NW, Washington, DC 20001

LIGHTING

MCLA
1000 Potomac St NW, Suite 121, Washington, DC 20007

FOOD SERVICE

Hopkins Foodservice Specialists, Inc.
7906 MacArthur Blvd, Suite 100, Cabin John, MD 20818

POOL DESIGN

AQUA Design International
7536 N. La Cholla Blvd, Tucson, AZ 85741

KEYPLAN

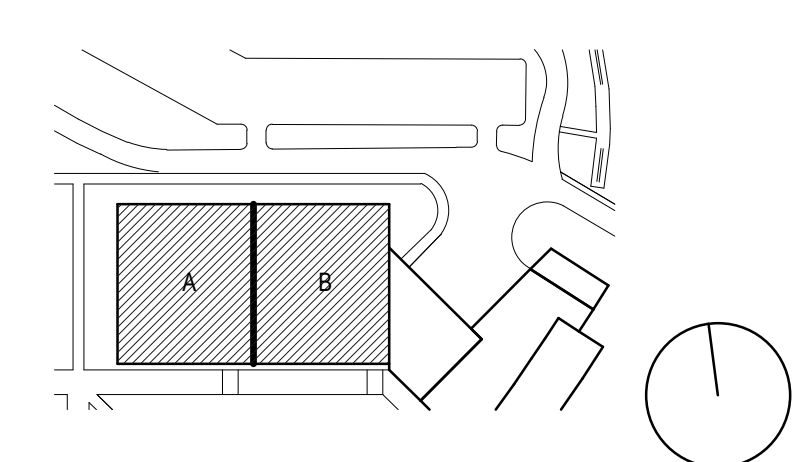

NO.	DATE	DESCRIPTION	NO.	DATE	DESCRIPTION
3	29 JUN 2023	ADDENDUM 29			
2	19 MAY 2023	ISSUED FOR BID			
1					

RECORD REVISIONS

SEAL

SIGNATURE _____ DATE _____

ARCHITECT

SOM
Skidmore, Owings & Merrill LLP
250 Greenwich St, New York, 10007

COMMONWEALTH OF PENNSYLVANIA
DEPARTMENT OF GENERAL SERVICES
HARRISBURG, PENNSYLVANIA

D.G.S. PROJECT No. **C-0211-0005 PHASE 5**

Pennsylvania State Police Academy
Core Buildings, BESO & Sitework
PENNSYLVANIA STATE POLICE
HERSHEY, DAUPHIN COUNTY, PA

VERIFY SCALE			
BAR IS ONE (1) INCH LONG ON ORIGINAL DRAWING: 0 1			
IF BAR IS NOT ONE (1) INCH LONG, ADJUST SCALE ACCORDINGLY			
CONTRACTOR SHALL FIELD VERIFY ALL DIMENSIONS. VARIANCE FROM CONTRACT DOCUMENTS NOT PERMITTED WITHOUT PROFESSIONAL & BUREAU OF CONSTRUCTION APPROVAL.			
SHEET No. GYM-M-701		SCALE AS NOTED	
DRAWN BY Author	CHECKED BY Checker	DATE FEB. 2022	SCALE AS NOTED

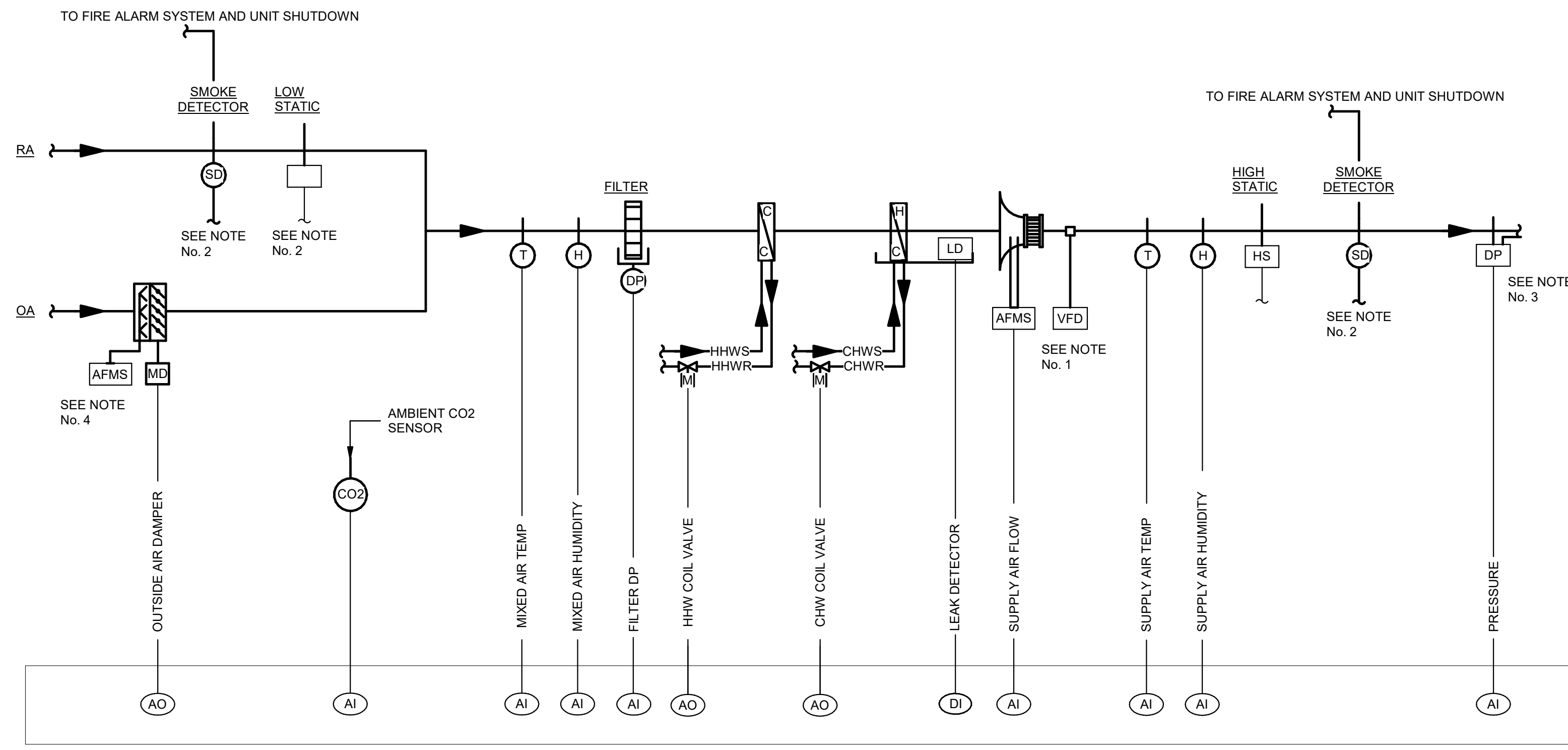

- NOTES:
- SEE SCHEDULES AND AIR HANDLING UNIT DETAILS FOR QUANTITY OF FANS, VFD'S AND ECM MOTORS.
 - HARDWIRED SMOKE DETECTOR AND HIGH STATIC ACTIVATIONS TO VFD/ECM MOTORS FOR FAN SHUTDOWN.
 - LOCATE DUCT DIFFERENTIAL PRESSURE SENSOR AT 2/3 DISTANCE DOWNSTREAM OF SUPPLY FAN.
 - AIRFLOW STATION AND INTEGRAL MOTORIZED DAMPER ARE EXTERNAL TO UNIT. REFER TO PLANS FOR LOCATIONS.
 - AMBIENT CO2 SENSOR TO BE MOUNTED IN OUTSIDE AIR DUCTWORK UPSTREAM OF AIR HANDLING UNIT.

GENERAL RUN CONDITIONS:

- AHU SHALL BE AUTOMATICALLY OR MANUALLY ENABLED TO RUN IN OCCUPIED MODE AS FOLLOWS:
 - AUTOMATIC OPERATION
 - MANUALLY SELECTED BY USER FROM GRAPHICAL INTERFACE
 - OPTIMAL START/STOP
 - AHU SHALL BE STOPPED:
 - AUTOMATICALLY IN UNOCCUPIED MODE
 - MANUALLY
 - FROM SAFETY SHUTDOWNS
 - OPEN FIRE AND SMOKE DAMPERS IN DISTRIBUTION DUCTWORK. AFTER 60 SECOND DELAY STARTS THE FANS TO ALLOW FIRE AND SMOKE DAMPERS TO OPEN WITHOUT CAUSING DUCT DAMAGE.
 - START SUPPLY FAN(S)
 - FANS SHALL RUN CONTINUOUSLY AND AS DESCRIBED HEREIN AFTER
 - OPEN NORMALLY CLOSED OUTDOOR AIR DAMPER OR MINIMUM OUTDOOR AIR DAMPER POSITION AND RESET MINIMUM OUTDOOR AIR QUANTITY TO MINIMUM DEMAND CONTROL VENTILATION (DCV) AIR QUANTITY POSITION WHERE A DCV VALUE IS SHOWN ON SCHEDULES.
 - AUTOMATIC OPERATION:
 - AUTOMATIC OPERATION IN OCCUPIED/UNOCCUPIED MODE SHALL BE DETERMINED THROUGH A USER-ADJUSTABLE, GRAPHICAL, SEVEN-DAY ZONE OCCUPANCY SCHEDULE WITH A HOLIDAY SCHEDULE. ZONE OCCUPANCY SCHEDULE SHALL AUTOMATICALLY SELECT THE UNOCCUPIED OR OCCUPIED MODE OF THE AHU. COORDINATE SCHEDULES WITH OWNER.
 - AT THE SCHEDULED OCCUPANCY TIME, THE UNIT SHALL START IF NOT ALREADY STARTED BY THE OPTIMAL START ROUTINE, AND THE UNIT SHALL BE SWITCHED TO THE OCCUPIED MODE.
 - SCHEDULED STOP: WHEN THE TIME SCHEDULE ENTERS THE UNOCCUPIED TIME PERIOD, THE BAS SHALL STOP THE AIR HANDLING UNIT.
 - UNOCCUPIED START/STOP: IN THE UNOCCUPIED MODE, THE BAS SHALL START THE UNIT AND OPERATE THE SYSTEM IN THE UNOCCUPIED COOLING MODE IF ANY SPACE TEMPERATURE RISES ABOVE 80°F (ADJ), OR IF THE SPACE RELATIVE HUMIDITY RISES ABOVE 65% RH. THE UNIT SHALL OPERATE UNTIL EITHER ALL SPACE TEMPERATURES HAVE DROPPED BELOW 85°F (ADJ) AND/OR THE SPACE RELATIVE HUMIDITY HAS DROPPED BELOW 55% (WORST CASE SCENARIO). THE FANS SHALL OPERATE FOR A MINIMUM OF 30MIN OR UNTIL THERE ARE NO ZONE HEATING/COOLING REQUESTS AS DEFINED AT THE VAV CONTROL LEVEL.
 - SHUTDOWN MODE
 - SHUT DOWN UNIT ACCORDING TO BAS SCHEDULE OR IF REQUIRED DUE TO SAFETIES, AND:
 - DISABLE FANS.
 - CLOSE OUTDOOR AND RELIEF AIR DAMPERS.
 - OPEN RETURN AIR DAMPER.
 - CLOSE CHILLED WATER CONTROL VALVE.
 - 60 SECONDS (ADJ) AFTER FAN SHUTDOWN CLOSE FIRE AND SMOKE DAMPERS IN DISTRIBUTION DUCTWORK
 - MORNING PRE-COOLING:
 - MORNING COOL-DOWN DOES NOT APPLY TO 100 PERCENT OUTDOOR AIR UNITS WITHOUT A RETURN AIR CONNECTION.
 - INITIATE MORNING COOL-DOWN MODE USING AN OPTIMAL START ALGORITHM THAT USES AN ADAPTIVE LEARNING FEATURE THAT AUTOMATICALLY ADJUSTS THE MORNING COOL-DOWN START TIME SO THAT THE AVERAGE ZONE TEMPERATURE IN THE EXTERIOR ZONES IS 78 DEGREES F (ADJ) AT THE SCHEDULED OCCUPIED START TIME.
 - DURING MORNING COOL-DOWN OPERATION:
 - UNIT AND APPLICABLE FANS OPERATE.
 - OPERATE UNIT IN MORNING COOL-DOWN OR SETBACK MODE, AS AVAILABLE.
 - SUPPLY FAN CONTROL:
 - SUPPLY FAN HAND-OFF-AUTO (HOA) OPERATION:
 - HOA SETTINGS SHALL BE PROVIDED AS PART OF THE VARIABLE FREQUENCY DRIVE THROUGH THE DRIVE'S KEYPAD FOR THE SUPPLY FAN. WHEN IN THE HAND MODE, THE FAN SHALL BE STARTED, IN THE OFF MODE, THE FAN SHALL BE OFF. IN THE AUTO MODE, THE FAN SHALL BE STARTED AND STOPPED THROUGH THE BAS. PROVIDE AN ADJUSTABLE DELAY-ON-MAKE RELAY, WIRED IN BOTH THE HAND AND AUTO MODES, TO STAGGER THE RESTART OF EACH UNIT AFTER A POWER FAILURE TO PREVENT CREATING A SPIKE IN THE FACILITY ELECTRICAL DEMAND. UPON ACTIVATION, SAFETIES SHALL STOP THE SUPPLY FAN IN THE HAND AND AUTO MODES.
 - SUPPLY FAN AUTOMATIC SPEED CONTROL:
 - WHEN THE SUPPLY FAN(S) ARRAY IS ON, THE BAS SHALL CONTROL THE SPEED OF THE FAN ARRAY IN UNISON TO MAINTAIN THE SUPPLY DUCT STATIC PRESSURE AS SENSED BY STATIC PRESSURE SENSOR. LOCATE STATIC PRESSURE SENSORS IN A POSITION THAT THE CONTROLLER SETPOINT IS NO GREATER THAN ONE THIRD OF THE TOTAL DESIGN FAN STATIC PRESSURE. IF THIS RESULTS IN THE SENSOR BEING LOCATED DOWNSTREAM OF MAJOR DUCT SPLITS, MULTIPLE SENSORS SHALL BE INSTALLED IN EACH MAJOR BRANCH TO ENSURE THAT STATIC PRESSURE CAN BE MAINTAINED IN EACH. PER ASHRAE 90.1, SECTION 6.5.3.2.2, WHEN THE SUPPLY DUCT STATIC PRESSURE IS BELOW THE SET POINT AT THE STATIC PRESSURE SENSOR(S), THE SPEED SHALL INCREASE AND WHEN THE SUPPLY DUCT STATIC PRESSURE IS ABOVE THE SET POINT AT ALL OF THE STATIC PRESSURE SENSORS, THE SPEED SHALL DECREASE. WHEN THE FAN IS OFF, THE VFD'S SHALL BE COMMANDED BY THE BAS TO THE UNLOADED POSITION (0%). THE FINAL DUCT STATIC PRESSURE SETPOINT SHALL BE DETERMINED IN CONSULTATION WITH THE BALANCING CONTRACTOR. CONDUCT STATIC PRESSURE MEASUREMENTS TO DOCUMENT COMPLIANCE. SUBMIT DOCUMENTATION FOR REVIEW AND APPROVAL PRIOR TO INSTALLING SENSORS. THE SUPPLY FAN SPEED SHALL NOT DROP BELOW 20% (ADJ) TO PROVIDE ADEQUATE MOTOR COOLING AND PREVENT FAN STALLING PHENOMENA.
 - FOR UNITS WITH MULTIPLE VFD'S, WITHOUT A STANDBY VFD, VARY THE SPEED OF VFD'S IN UNISON. SHUT DOWN LAG VFD WHEN THE SPEED OF VFD'S IS AT MINIMUM AND TURN ON THE LAG VFD(S) WHEN THE SPEED OF OPERATING VFD(S) IS AT 85 PERCENT OF PEAK SPEED OR AT FAILURE OF LEAD FAN(S) OR LEAD VFD. ON FAILURE OF LEAD FAN(S) OR LEAD VFD SHUT DOWN LEAD VFD AND START LAG VFD THROUGH HARDWIRE CONNECTION BETWEEN VFD'S.
 - AN AIRFLOW MONITORING STATION SHALL CONTINUOUSLY MONITOR THE TOTAL SUPPLY AIR FAN VOLUME IN CFM AND SEND AN OUTPUT TO THE BAS.
- SUPPLY DUCT STATIC PRESSURE SETPOINT RESET:
- THE BAS SHALL MONITOR THE VAV TERMINAL UNIT ASSOCIATED DAMPER POSITION. THE CONTROLLER SHALL BE COMMUNICATING WITH ALL VAV TERMINAL UNITS TO OBTAIN ZONE PRESSURE REQUESTS. A ZONE PRESSURE REQUEST IS GENERATED WHEN THE DAMPER IS GREATER THAN 90% OPEN AND UNTIL IT DROPS TO 80% OPEN. THE STATIC PRESSURE SETPOINT SHALL BE RESET BASED ON ZONE PRESSURE REQUESTS, DERIVED FROM DAMPER POSITIONS AND MEETING THE OUTSIDE AIRFLOW REQUIREMENTS, USING THE TRIM AND RESPOND LOGIC DESCRIBED HEREINAFTER.
 - RESET SUPPLY AIR DUCT STATIC PRESSURE SETPOINT BETWEEN 0.15-INCH (ADJ) AND SCHEDULED MAXIMUM UNIT ESP (ADJ) AT A MAXIMUM RATE OF 0.1 - INCH (ADJ) EVERY 5 MINUTES (ADJ), UNTIL THERE ARE ZERO (ADJ) ZONE PRESSURE REQUESTS. WHEN THERE ARE ZERO ZONE PRESSURE REQUESTS, GRADUALLY REDUCE (TRIM) THE STATIC PRESSURE SETPOINT AT A MAXIMUM RATE OF 0.1 IN WG (ADJ) EVERY 5 MINUTES. WHEN ZONE PRESSURE REQUESTS INCREASE, THE REVERSE SHALL OCCUR AND THE STATIC PRESSURE SETPOINT SHALL BE GRADUALLY INCREASED AS DESCRIBED ABOVE.
 - WHEN UNIT IS ENABLED IN ANY MODE, SET INITIAL SUPPLY AIR STATIC PRESSURE SETPOINT AT 0.5-INCH (ADJ).
 - IN THE EVENT OF LOSS OF COMMUNICATION WITH ONE OR MORE VAV TERMINAL UNIT CONTROLLERS THE SYSTEM SHALL REVERT TO MODULATING THE FAN SPEED TO MAINTAIN THE DUCT STATIC PRESSURE SETPOINT OF NEGATIVE .05 IN WG (ADJ) AND/OR TO MAINTAIN OUTSIDE AIRFLOW REQUIREMENTS.
- SUPPLY AIR TEMPERATURE SETPOINT RESET:
- THE BAS SHALL MONITOR THE VAV TERMINAL UNIT DAMPER POSITION. EACH AHU CONTROLLER SHALL BE COMMUNICATING WITH ALL ASSOCIATED VAV TERMINAL UNITS TO OBTAIN ZONE COOLING REQUESTS. A ZONE COOLING REQUEST IS GENERATED BY A VAV TERMINAL UNIT WHEN THE VAV DAMPER IS GREATER THAN 90% (ADJ) OPEN AND UNTIL IT DROPS TO 85% (ADJ) OPEN.
 - THE BAS SHALL MONITOR THE AHU DISCHARGE AIR TEMPERATURE AND SHALL RESET THE DISCHARGE AIR TEMPERATURE SETPOINT BASED ON SATISFACTION OF ALL ZONE COOLING REQUIREMENTS.
 - THE SETPOINT SHALL BE RESET USING THE TRIM AND RESPOND LOGIC DESCRIBED HEREINAFTER. THE INITIAL SETPOINT SHALL BE 55°F (ADJ). DURING OCCUPIED MODE, THE SETPOINT SHALL BE RESET FROM 55°F (ADJ) UP TO A TMAX OF 65°F. WHEN FAN IS OFF, TMAX SHALL BE EQUAL TO THE MINIMUM VALUE OF 55°F. WHEN FAN IS PROVEN ON, IF THERE ARE TWO OR LESS ZONE COOLING REQUESTS INCREASE THE SETPOINT BY 0.3°F (ADJ), EVERY 2 MIN (ADJ). IF THERE ARE MORE THAN TWO ZONE COOLING REQUESTS AND AHU STATIC PRESSURE SETPOINT IS AT THE MAX VALUE (1.5 IN WG), DECREASE THE SETPOINT BY 0.3°F (ADJ), EVERY 2 MIN (ADJ).
- DEHUMIDIFICATION MODE:
- A MIXED AIR RELATIVE HUMIDITY SENSOR SHALL OVERRIDE THE SUPPLY AIR TEMPERATURE RESET STRATEGY DESCRIBED ABOVE TO MAINTAIN A MAXIMUM OF 60% RH (ADJ) FOR THE AREA SERVED BY THE AHU. IF MIXED AIR RH IS GREATER THAN MAXIMUM SETPOINT AND AHU DISCHARGE AIR TEMPERATURE IS ABOVE INITIAL SETPOINT OF 55°F (ADJ), THEN RESET DISCHARGE AIR TEMPERATURE SETPOINT (TO 55°F). IF AFTER 30MIN (ADJ) RELATIVE HUMIDITY IS LOWER THAN MAXIMUM SETPOINT, RE-ENABLE SUPPLY AIR TEMPERATURE SETPOINT.
- RESET STRATEGY COORDINATION:
- THE SUPPLY AIR TEMPERATURE SETPOINT RESET STRATEGY AND SUPPLY DUCT STATIC PRESSURE SETPOINT RESET STRATEGY SHALL BE IMPLEMENTED IN COORDINATION WITH EACH OTHER SUCH THAT THEY DO NOT OVERLAP. BAS CONTRACTOR SHALL IDENTIFY STRATEGY INTERACTIONS, DETECT POSSIBLE OPERATIONAL ISSUES FOR EACH SYSTEM THROUGH TREND ANALYSIS AND SHALL OPTIMIZE OPERATIONS.

1 VAV AIR HANDLING UNIT SYSTEM CONTROL DIAGRAM WITHOUT ERV (G-AHU-1, G-AHU-2, G-AHU-3, G-AHU-5)

NO SCALE

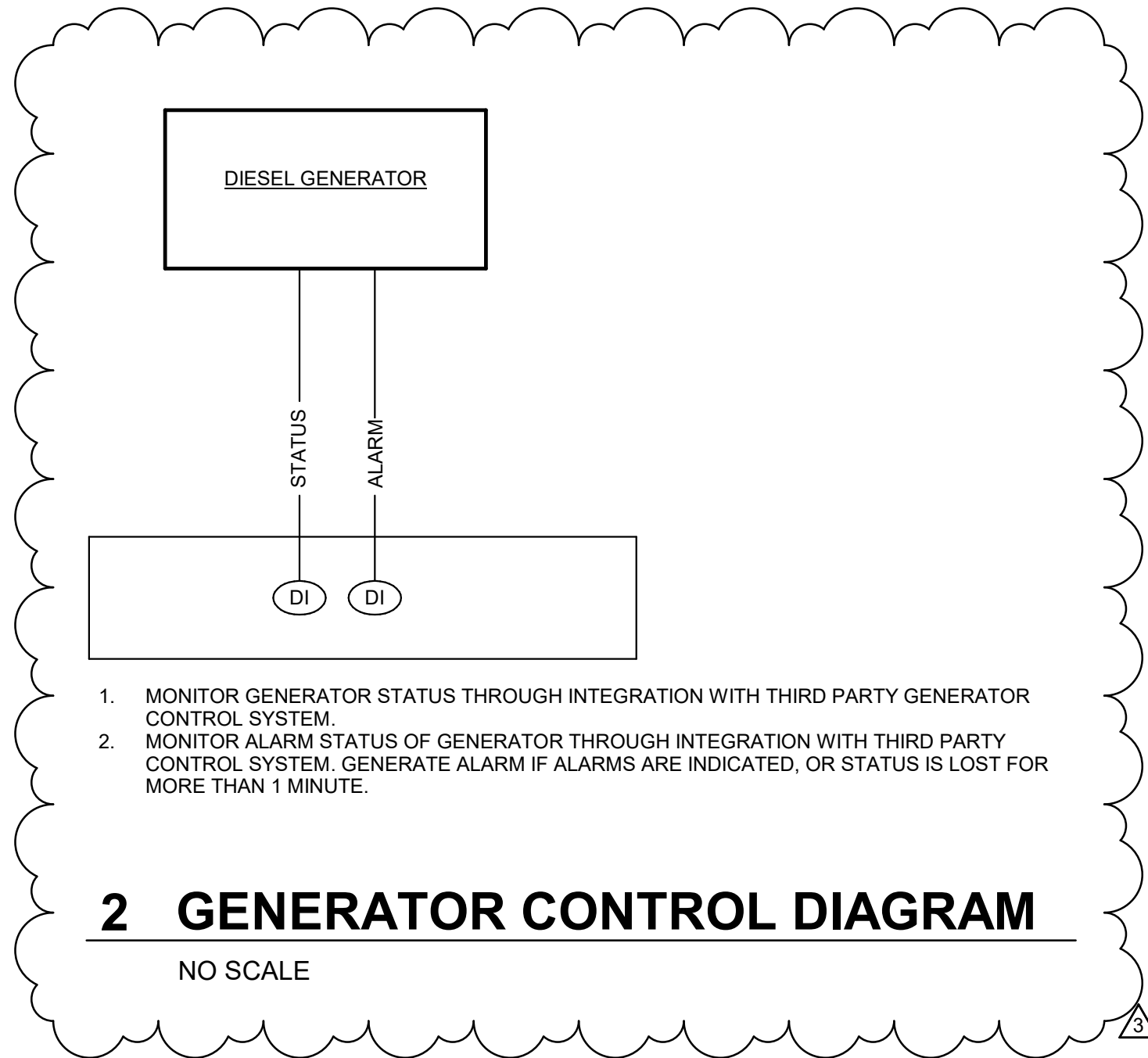

MINIMUM OUTDOOR AIR CONTROL:

- WHEN THE UNIT IS OFF OR THE UNIT IS STARTED IN THE UNOCCUPIED AND COOL DOWN MODES, THE MINIMUM OUTDOOR AIR DAMPER SHALL BE CLOSED. EXCEPTION: A SYSTEM MAY REQUIRE ABSOLUTE MINIMUM OUTSIDE AIR FOR MAINTAINING TRANSFER AIR OR EXHAUST AIR PRESSURE RELATIONSHIPS DURING SCHEDULED UNOCCUPIED PERIODS. THIS SHALL BE COORDINATED DURING COMMISSIONING.
- WHEN THE UNIT IS STARTED IN THE OCCUPIED MODE THE OUTSIDE AIR DAMPER SHALL BE OPENED TO THE MINIMUM POSITION. THE MINIMUM OUTSIDE AIR SHALL BE MEASURED AND THE OUTSIDE AIR DAMPER DAMPER SHALL BE MODULATED AND CONTROLLED TO MAINTAIN VENTILATION AND PRESSURIZATION REQUIREMENTS.
- THE OUTSIDE AIR AIRFLOW MEASURING STATION SHALL MONITOR THE MINIMUM OUTSIDE AIR VOLUME IN CFM AND SEND OUTPUT TO THE BAS TO MAINTAIN OA CFM SETPOINT AS SYSTEM FANS MODULATE. MODULATE MINIMUM OA DAMPER AT 100% OPEN IN AN ATTEMPT TO ACHIEVE MEASURED OUTSIDE AIRFLOW SETPOINT.
- OA CFM INPUT, OUTPUT AND DAMPER POSITION SHALL BE MONITORED AND GRAPHICALLY DISPLAYED IN THE BAS.

DEMAND CONTROL VENTILATION:

- DURING OCCUPIED MODE, DEMAND VENTILATION CONTROLS SHALL MONITOR SPACES WITH CO2 SENSORS. PROVIDE AN ENABLE/DISABLE FUNCTION FOR DEMAND CONTROL VENTILATION FUNCTION. IN THE DISABLE MODE, WHEN THE UNIT IS ON, THE OUTSIDE AIRFLOW DAMPER SHALL MODULATE TO MAINTAIN THE SCHEDULED OUTSIDE AIR FLOW VALUE. IN THE ENABLE MODE, THE BAS SHALL MONITOR SPACES WITH CO2 SENSORS. AS CO2 SIGNAL FROM THE ZONES SERVED BY THE SYSTEM RISES ABOVE SETPOINT, THE BAS SHALL FIRST INCREASE CRITICAL ZONE MINIMUM AIRFLOW TO SATISFY VENTILATION REQUIREMENTS, AND THEN INCREASE THE OUTDOOR RATE AT THE AIR HANDLER AS DESCRIBED HEREINAFTER.
 - ZONE LEVEL: UPON A RISE IN ZONE CO2 CONCENTRATION ABOVE SETPOINT, THE MINIMUM OCCUPIED AIRFLOW SETPOINT AT THE ZONE VAV TERMINAL SHALL FIRST BE RESET FROM THE DESIGN MINIMUM UP TO THE MAXIMUM VALUE (ADJ). CO2 SETPOINT+AMBIENT CO2 CONCENTRATION + 60PPM (ADJ).
 - AHU LEVEL: UPON CONTINUED CALL FOR VENTILATION BASED IN CONTINUED RISE OF CO2 CONCENTRATION IN CO2 MONITORED ZONES, THE MINIMUM OUTDOOR AIR SETPOINT SHALL BE RESET, BASED ON THE HIGHEST ZONE CO2 LOOP SIGNAL FROM ABSOLUTE MINIMUM TO THE DESIGN MINIMUM. REFERENCE AHU CO2 RESET SCHEDULE TO OBTAIN ABSOLUTE MINIMUM AND DESIGN MINIMUM AIRFLOW RATES. ABSOLUTE MINIMUM IS THE UNOCCUPIED DESIGN MINIMUM OUTSIDE AIR QUANTITY AND DESIGN MINIMUM IS THE OCCUPIED DESIGN OUTSIDE AIR QUANTITY.

SPACE TEMPERATURE SET POINT CONTROL:

- THE BAS SHALL MAINTAIN THE SPACE TEMPERATURE SET POINT ACCORDING TO THE FOLLOWING. SPACE TEMPERATURE CONTROL SHALL BE RESTRICTED SUCH THAT THE SUPPLY AIR TEMPERATURE SHALL NEVER FALL BELOW 55°F (ADJ) OR RISE ABOVE 85°F (ADJ).
 - OCCUPIED COOLING SET POINT - 75°F

CHILLED WATER VALVE CONTROL:

- WHEN THE UNIT STATUS IS OFF, THE CHILLED WATER VALVE SHALL BE CLOSED. WHEN THE UNIT STATUS IS ON, THE CHILLED WATER VALVE SHALL BE CONTROLLED AS DESCRIBED BELOW.
 - UNOCCUPIED COOLING AND COOL DOWN MODES: WHEN THE UNIT IS ON IN THE UNOCCUPIED COOLING AND COOL DOWN MODES, THE BAS SHALL MODULATE THE CHILLED WATER VALVE TO MAINTAIN A SUPPLY AIR TEMPERATURE PER THE SCHEDULE.
 - OCCUPIED MODE: IN THE OCCUPIED MODE, THE BAS SHALL MODULATE THE CHILLED WATER VALVE LAST IN SEQUENCE TO MAINTAIN AHU DISCHARGE AIR LEAVING TEMPERATURE COOLING SETPOINT, NORMALLY LIMITED TO 55°F (ADJ). THIS COOLING SETPOINT SHALL BE RESET BASED ON THE DISCHARGE AIR SETPOINT DESCRIBED IN THE PERTINENT SECTION ABOVE.

HOT WATER VALVE CONTROL:

- WHEN THE UNIT STATUS IS OFF, THE HOT WATER VALVE SHALL BE CLOSED. WHEN THE UNIT STATUS IS ON, THE HOT WATER VALVE SHALL BE CONTROLLED AS DESCRIBED BELOW.
 - OCCUPIED HEATING AND WARM UP MODES: WHEN THE UNIT IS ON IN THE UNOCCUPIED HEATING AND WARM UP MODES, THE BAS SHALL MODULATE THE HOT WATER VALVE TO MAINTAIN A SUPPLY AIR TEMPERATURE PER THE SCHEDULE.

SAFETY SHUTDOWNS AND ALARMS:

- FIRE ALARM SHUTDOWN CONTROL:
 - THE SUPPLY AND EXHAUST FANS SHALL BE INTERLOCKED WITH THE FIRE ALARM SYSTEM THROUGH A CONTROL MODULE (CM). THE CONTROL MODULE SHALL BE HARD WIRE INTERLOCKED TO CONTROL THE SUPPLY FAN IN THE HAND AND AUTO OPERATING MODES. EXHAUST FAN SHUTDOWN WILL OCCUR THROUGH THE HARDWIRED INTERLOCK WITH THE SUPPLY FAN.
 - SMOKE DAMPERS INSTALLED IN THE SUPPLY AND EXHAUST DUCT MAINS AT THE AHU SHALL BE INTERLOCKED WITH THE FIRE ALARM SYSTEM THROUGH A CONTROL MODULE (CM). THE CONTROL MODULE SHALL BE HARD WIRE INTERLOCKED TO CONTROL THE SMOKE DAMPER. CONTRACTOR SHALL COORDINATE WITH PLANS AND PROVIDE CONTROL POINTS, SEQUENCES AND GRAPHICS AS REQUIRED.
 - THE DUCT SMOKE DETECTOR LOCATED IN THE SUPPLY/RETURN AIR OF THE UNIT WILL BE MONITORED BY THE FIRE ALARM SYSTEM. THE FIRE ALARM SYSTEM SHALL BE PROGRAMMED TO ACTIVATE THE CONTROL MODULE AND THE SYSTEM SHALL OPERATE AS FOLLOWS:
 - WHEN PRODUCTS OF COMBUSTION ARE SENSED BY THE SUPPLY/RETURN AIR DUCT SMOKE DETECTOR, THE CONTROL MODULES SHALL STOP THE FANS IN THE HAND AND AUTO OPERATING MODES AND CLOSE THE ASSOCIATED SMOKE DAMPERS.
 - WHEN THE PRODUCTS OF COMBUSTION ARE CLEARED AND THE FIRE ALARM SYSTEM IS RESET, THE CONTROL MODULE SHALL RESTORE NORMAL CONTROL TO THE FANS.
 - REMOTE SMOKE DAMPERS OR COMBINATION FIRE/SMOKE DAMPERS INSTALLED IN THE SUPPLY AND RETURN DUCT SYSTEM ASSOCIATED WITH THE CONTROL MODULE (CM). THE CONTROL MODULE SHALL BE HARD WIRE INTERLOCKED TO CONTROL THE SMOKE DAMPER. CONTRACTOR SHALL COORDINATE WITH PLANS AND PROVIDE CONTROL POINTS, SEQUENCES AND GRAPHICS AS REQUIRED.
- HIGH PRESSURE SWITCH:
 - WHEN THE HIGH PRESSURE SWITCH TRIPS, THE UNIT SHALL BE STOPPED THROUGH A HARD WIRE INTERLOCK. AN ALARM SHALL BE GENERATED IN THE BAS AND DISPLAYED AT THE OWS. THE HIGH PRESSURE SWITCH SHALL BE SET TO TRIP AT 4" WC. (MANUALLY ADJUSTABLE) AND MUST BE MANUALLY RESET AT THE HIGH PRESSURE SWITCH.
- LOW PRESSURE SWITCH:
 - PRESSURE SWITCH SHALL DISABLE RETURN FAN IF FIRE/SMOKE DAMPER IN RETURN DUCT CLOSURES. WHEN THE LOW PRESSURE SWITCH TRIPS, THE UNIT SHALL BE STOPPED THROUGH A HARD WIRE INTERLOCK. AN ALARM SHALL BE GENERATED IN THE BAS. THE LOW PRESSURE SWITCH SHALL BE SET TO TRIP AT -3" WC. (MANUALLY ADJUSTABLE) AND MUST BE MANUALLY RESET AT THE LOW PRESSURE SWITCH.
- DIRTY FILTER ALARM:
 - DIFFERENTIAL PRESSURE SWITCHES SHALL MONITOR THE PRESSURE DROP AT THE FILTERS. WHEN THE PRESSURE EXCEEDS AN ADJUSTABLE LIMIT, AN ALARM SIGNAL WILL BE SENT. PRESSURE DIFFERENCE INDICATORS, LOCATED AT THE FILTERS, SHALL INDICATE THE DIFFERENTIAL PRESSURE ACROSS THE FILTERS. EACH FILTER SHALL BE PROVIDED WITH INDIVIDUAL DIRTY PRESSURE SETPOINTS, FILTERS MAY NOT BE COMBINED FOR A SINGLE DIRTY PRESSURE DIFFERENTIAL.
- OUTSIDE AIRFLOW ALARM:
 - WHENEVER THE OUTSIDE AIRFLOW, AS MEASURED BY THE UNIT'S OA AFMS, VARIES FROM THE SETPOINT BY MORE THAN 15% FOR MORE THAN 15MIN(ADJ.) AN ALARM SHALL BE RAISED TO THE BAS.
- FAN STATUS:
 - THE CURRENT RELAYS SHALL BE USED TO MONITOR THE STATUS OF THE UNIT SUPPLY AND EXHAUST FANS. IF THE STATUS INDICATED DOES NOT MATCH THE COMMANDED OUTPUT FOR A FAN, AN ALARM SHALL BE GENERATED.
- TEMPERATURE AND HUMIDITY ALARM:
 - AN ALARM SHALL BE GENERATED AT THE BAS IF THE SUPPLY AIR DISCHARGE TEMPERATURE IS ABOVE OR BELOW SETPOINT BY +/-5°F
 - AN ALARM SHALL BE GENERATED AT THE BAS IF THE SUPPLY AIR DISCHARGE HUMIDITY IS ABOVE SETPOINT BY + 10%

TACTICAL TRAINING DESIGN

Tactical Design North, Inc.
231 E. Buffalo St #502, Milwaukee, WI 53202

LOCAL ARCHITECT

Jacobs Wyper Architects
1232 Chancellor St, Philadelphia, PA 19107

STRUCTURAL ENGINEER

Skidmore, Owings & Merrill LLP
250 Greenwich St, New York, NY 10007

ELECTRICAL, PLUMBING, FIRE PROTECTION, FIRE ALARM ENGINEER

A & J Consulting Engineering Services, P.C.
164 Brighton Rd, Clifton, NJ 07012

MECHANICAL AVIT ENGINEER

Interface Engineering, Inc.
2000 M Street NW, Suite 270, Washington, DC 20036

ACOUSTICAL ENGINEER

Cerami
1001 Ave of the Americas, 4th Floor, New York, NY 10018

CODE CONSULTING

CCI
215 W 40th St, 10th Floor, New York, NY 10018

CIVIL ENGINEER

Langan
1818 Market St #3300, Philadelphia, PA 19103

VERTICAL TRANSPORT

Michael Blades & Associates Ltd.
5409 Rapijan Ct, Lothian, MD 20711

SIGNAGE CONSULTANT

Patricia Hord Graphik Design
119 S. St. Asaph St, Alexandria, VA 22314

LANDSCAPE

Lee and Associates, Inc.
638 I Street NW, Washington, DC 20001

LIGHTING

MCLA
1000 Potomac St NW, Suite 121, Washington, DC 20007

POOL SERVICE

Hopkins Foodservice Specialists, Inc.
7906 MacArthur Blvd, Suite 100, Cabin John, MD 20818

LANDSCAPE

AQUA Design International
7536 N. La Cholla Blvd, Tucson, AZ 85741

KEYPLAN

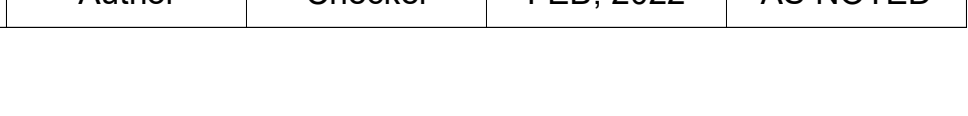
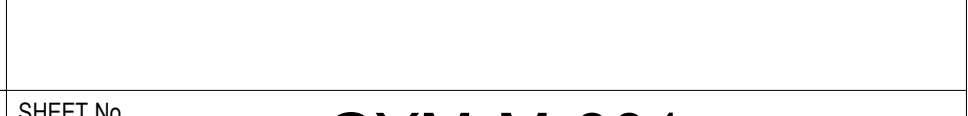
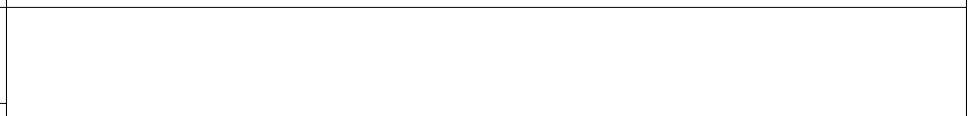
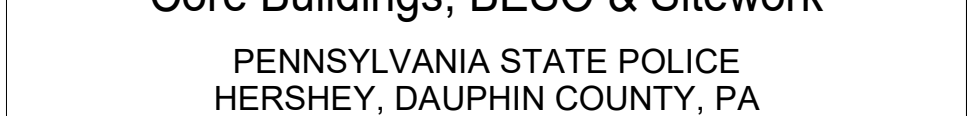
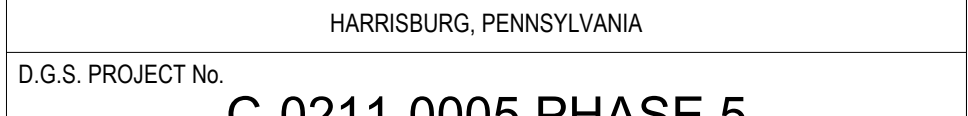
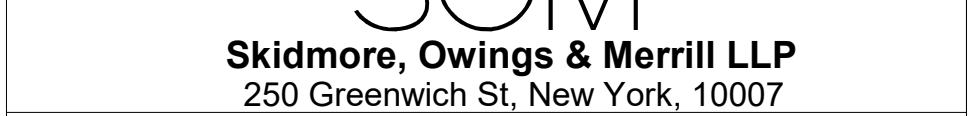
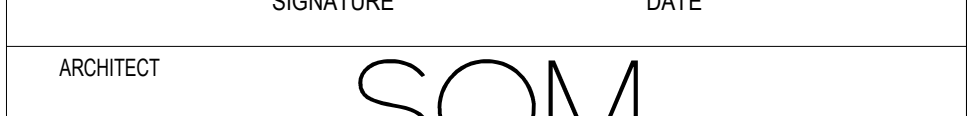
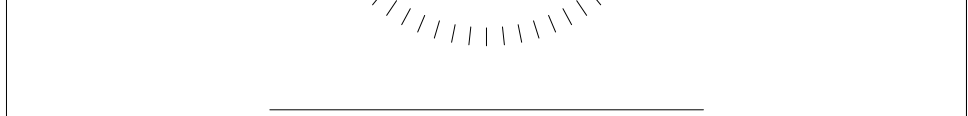
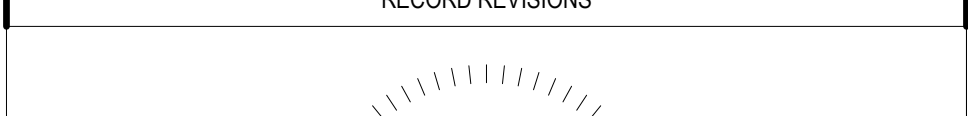
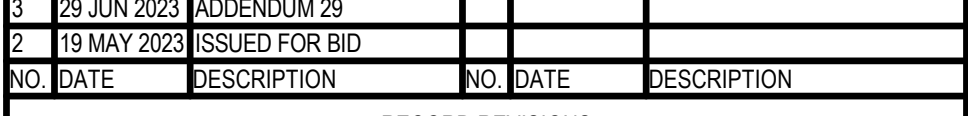
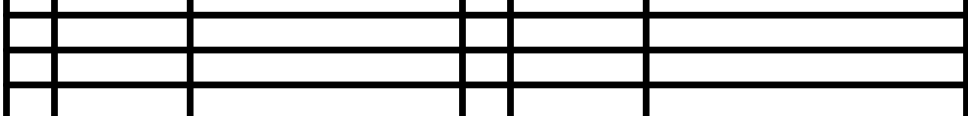
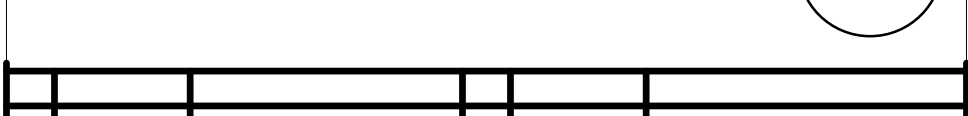
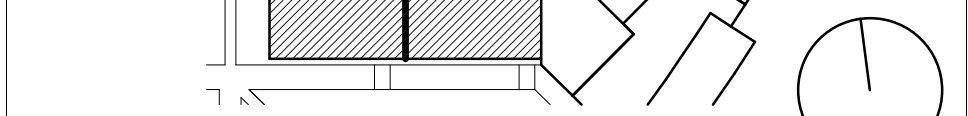
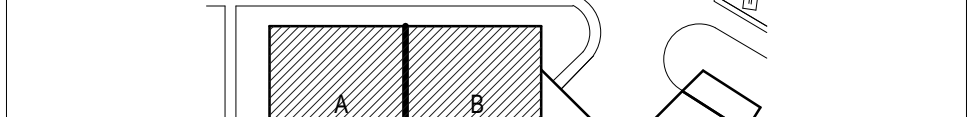
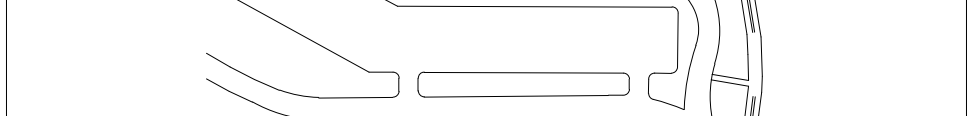
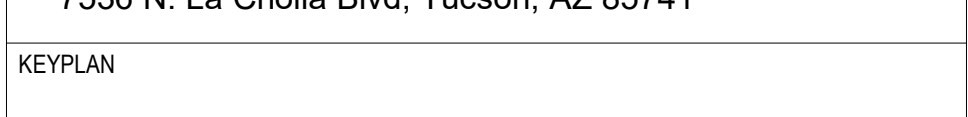

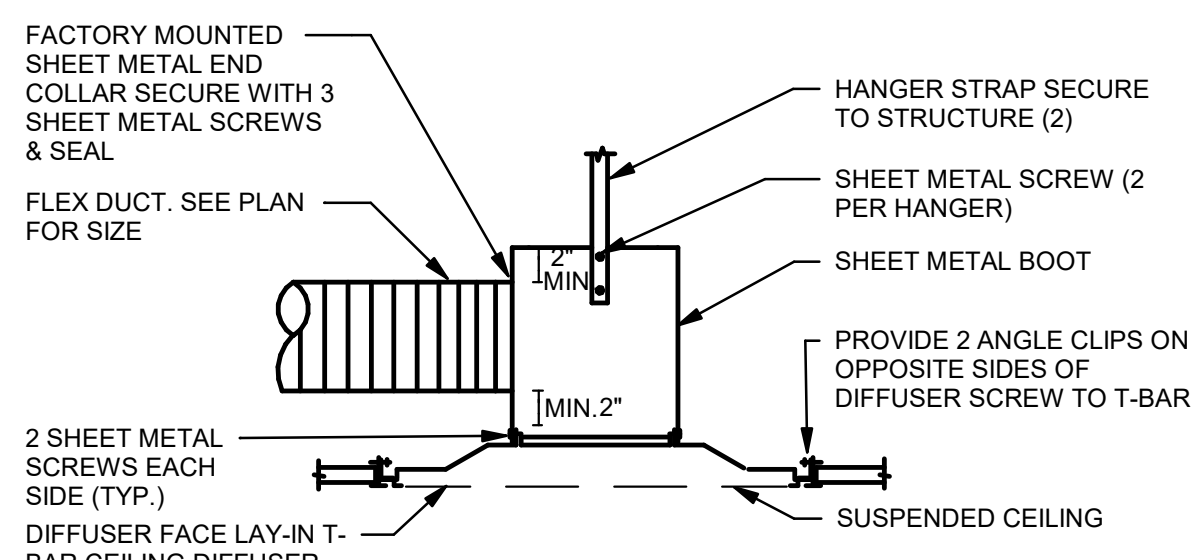

NOTES:
 A. USE THIS DETAIL WHERE 1.5 x RADIUS ON FLEXIBLE DUCT IS NOT POSSIBLE.
 B. SIMILAR FOR GYP BOARD CEILING.

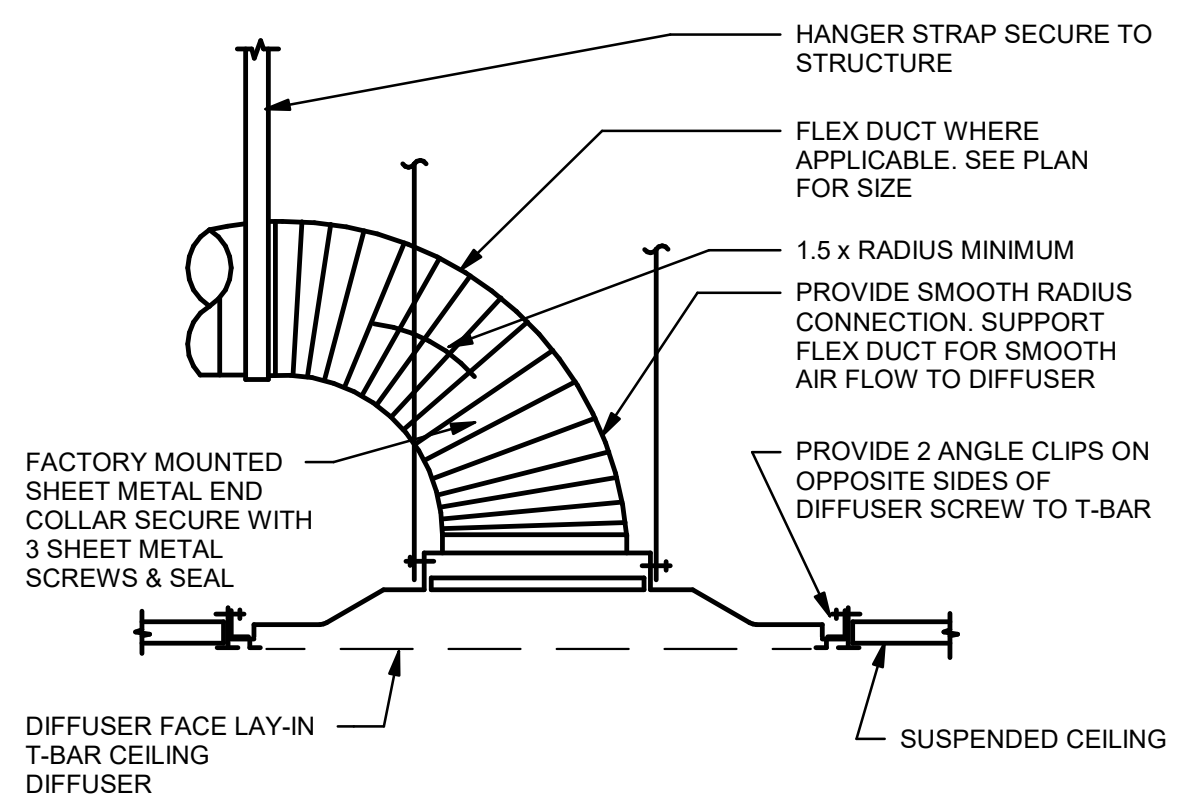

NOTES:
 A. USE MOUNTING DETAIL WHERE SPACE PERMITS. WHERE SPACE DOES NOT PERMIT FOLLOW DETAIL ABOVE.
 B. SIMILAR FOR GYP BOARD, SPLINE CEILING.

1 CEILING DIFFUSER CONNECTION DETAIL

NO SCALE

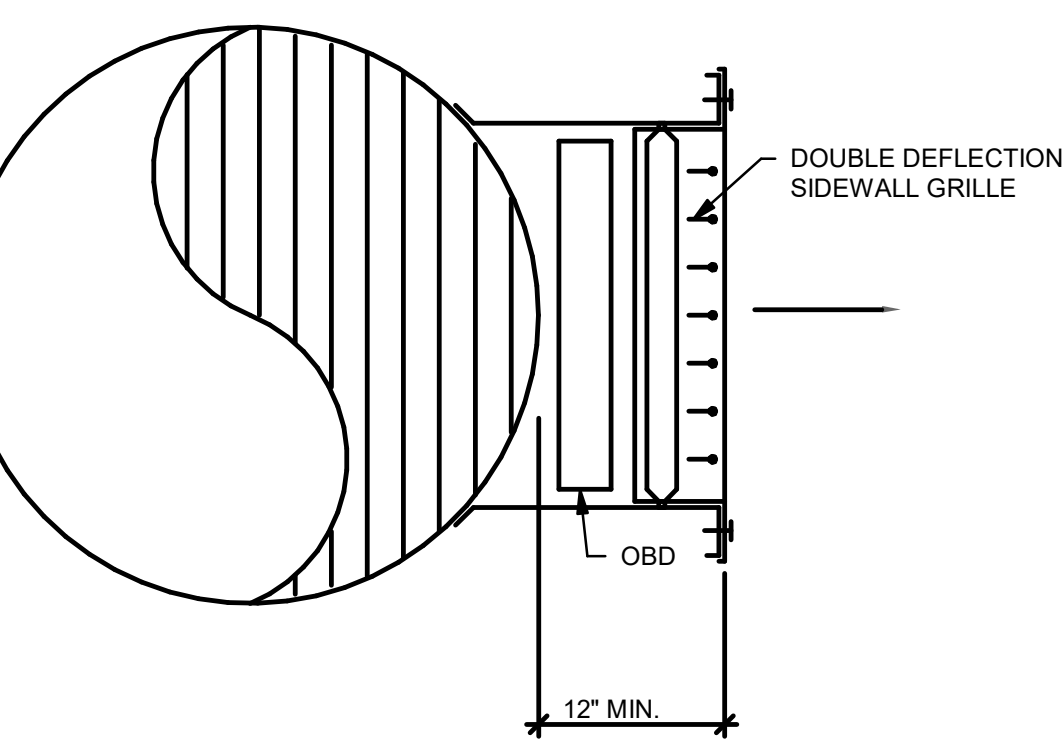

2 DUCT MOUNTED DIFFUSER CONNECTION DETAIL

NO SCALE

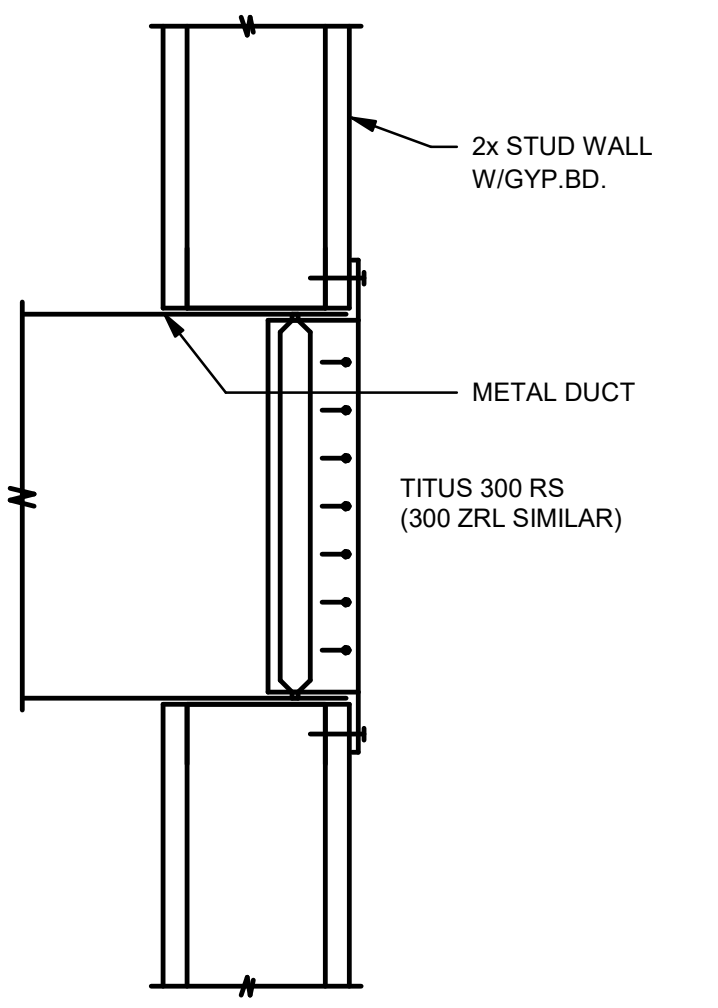

3 SIDEWALL DIFFUSER CONNECTION DETAIL

NO SCALE

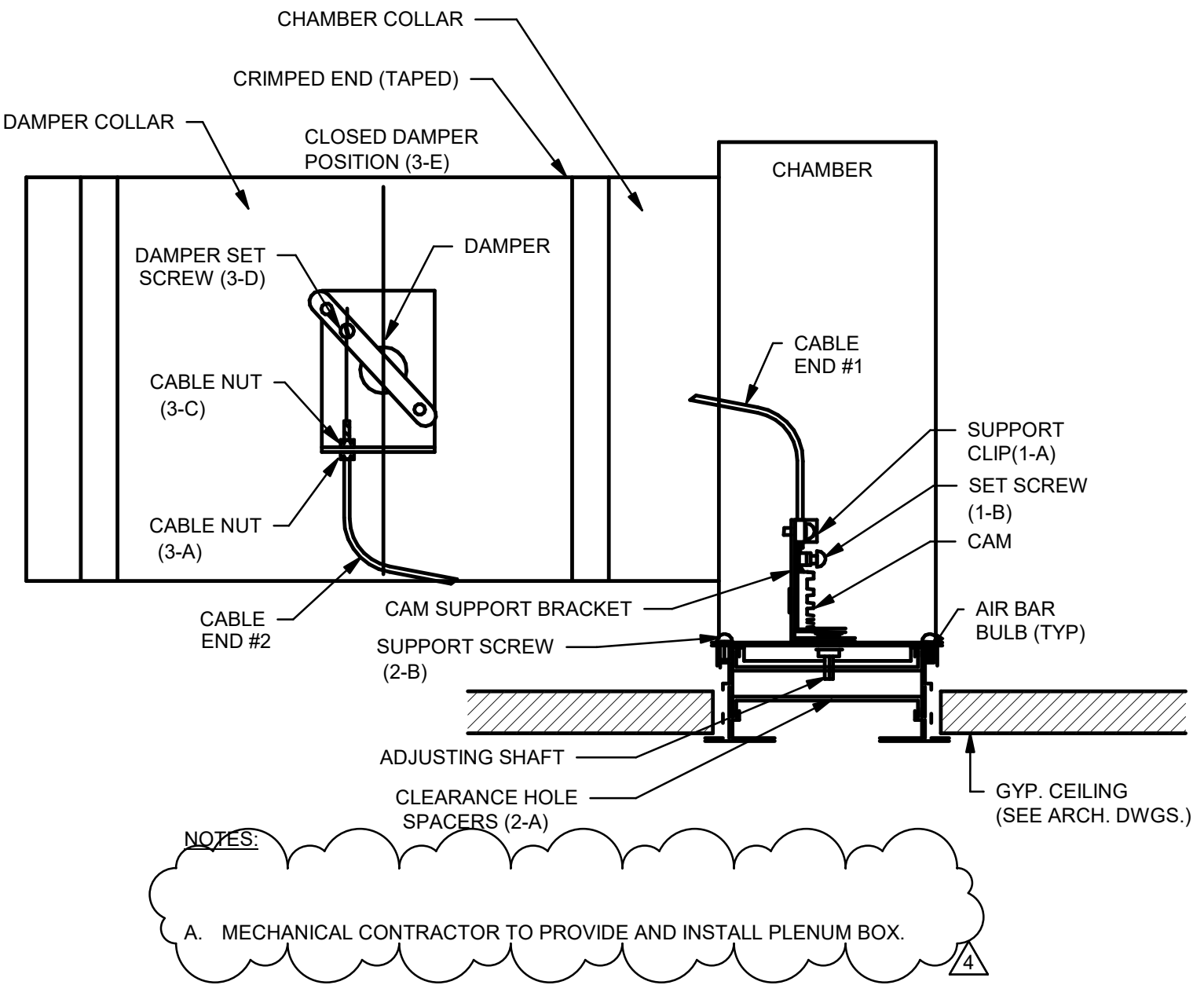

4 SLOT WITH INTEGRAL VOLUME DAMPER

NO SCALE

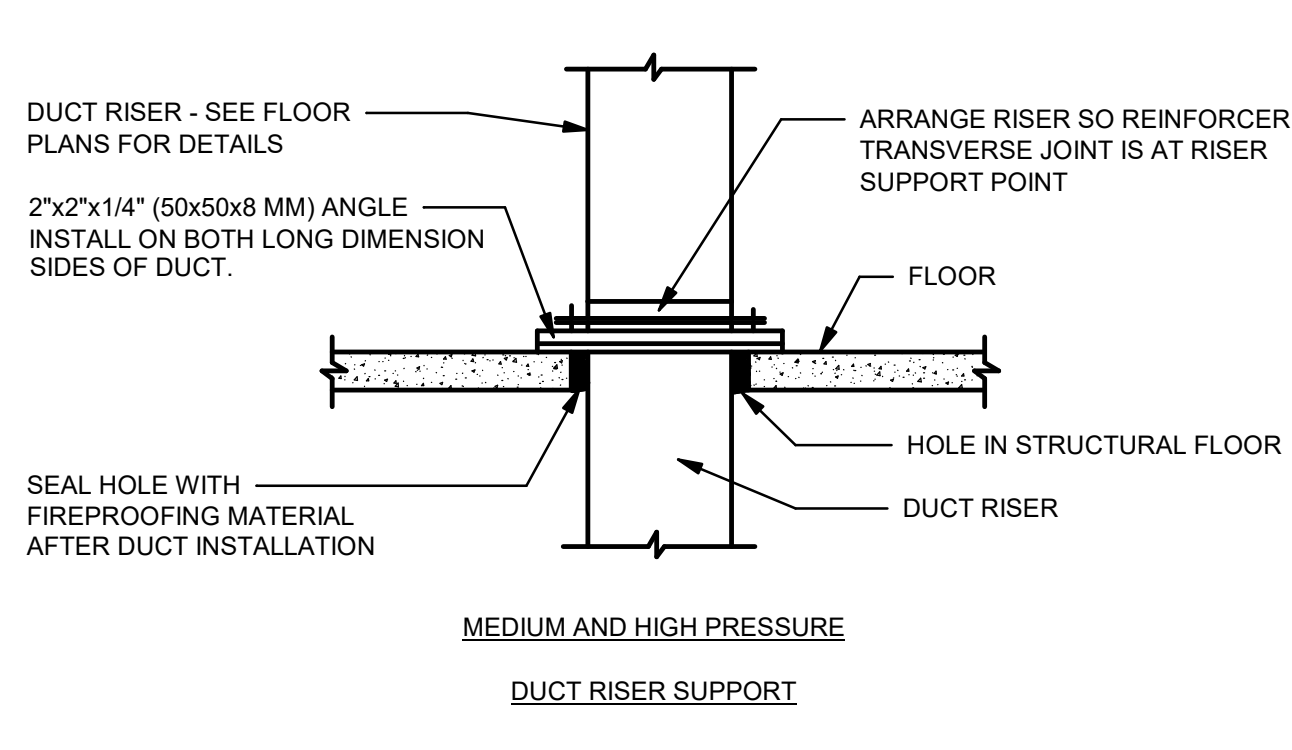
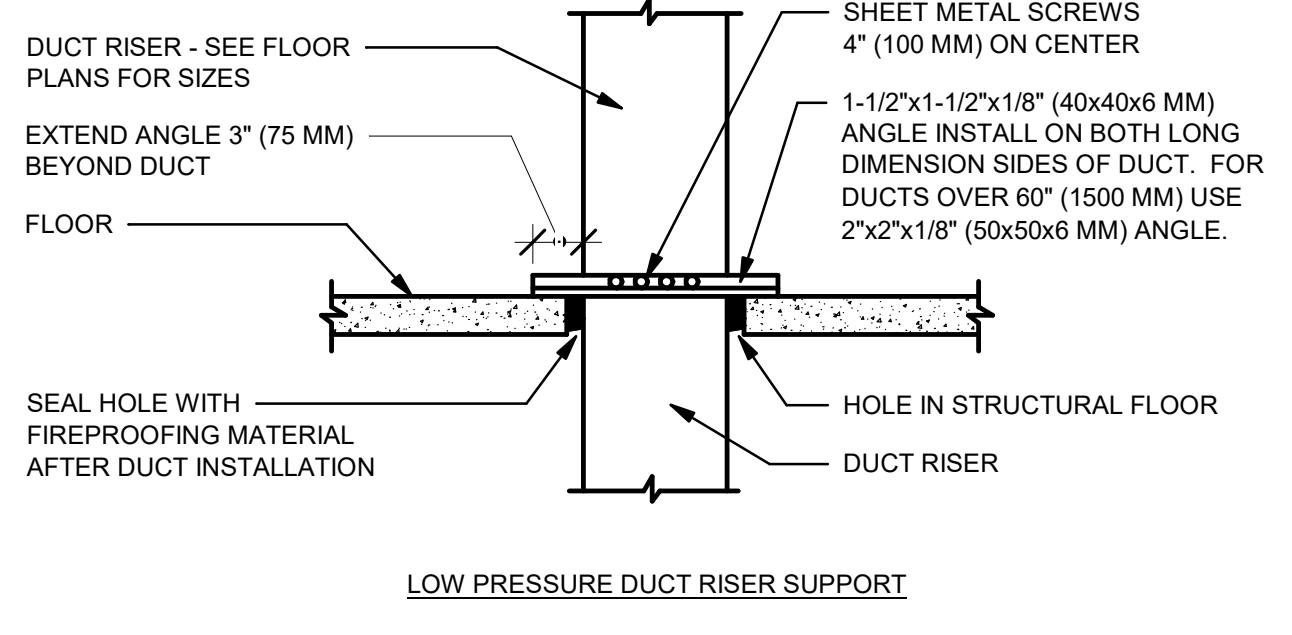

NOTE:
 1. ALL DUCT WORK RISERS WHICH ARE RUN EXPOSED, SUCH AS THRU ATTIC FLOORS AND FAN ROOM FLOORS SHALL BE PROVIDED WITH A 3" (75 MM) HIGH CONCRETE CURB AROUND OPENING FOR DUCT.

DESIGNER'S NOTE:
 1. INDICATE ON DRAWING WHICH DUCTS ARE LOW PRESSURE (2" (50 MM) WG OR LESS) AND WHICH ARE MEDIUM AND HIGH PRESSURE (2" (50 MM) WG TO 10" (250 MM) WG).

5 DUCT RISER SUPPORT

NO SCALE

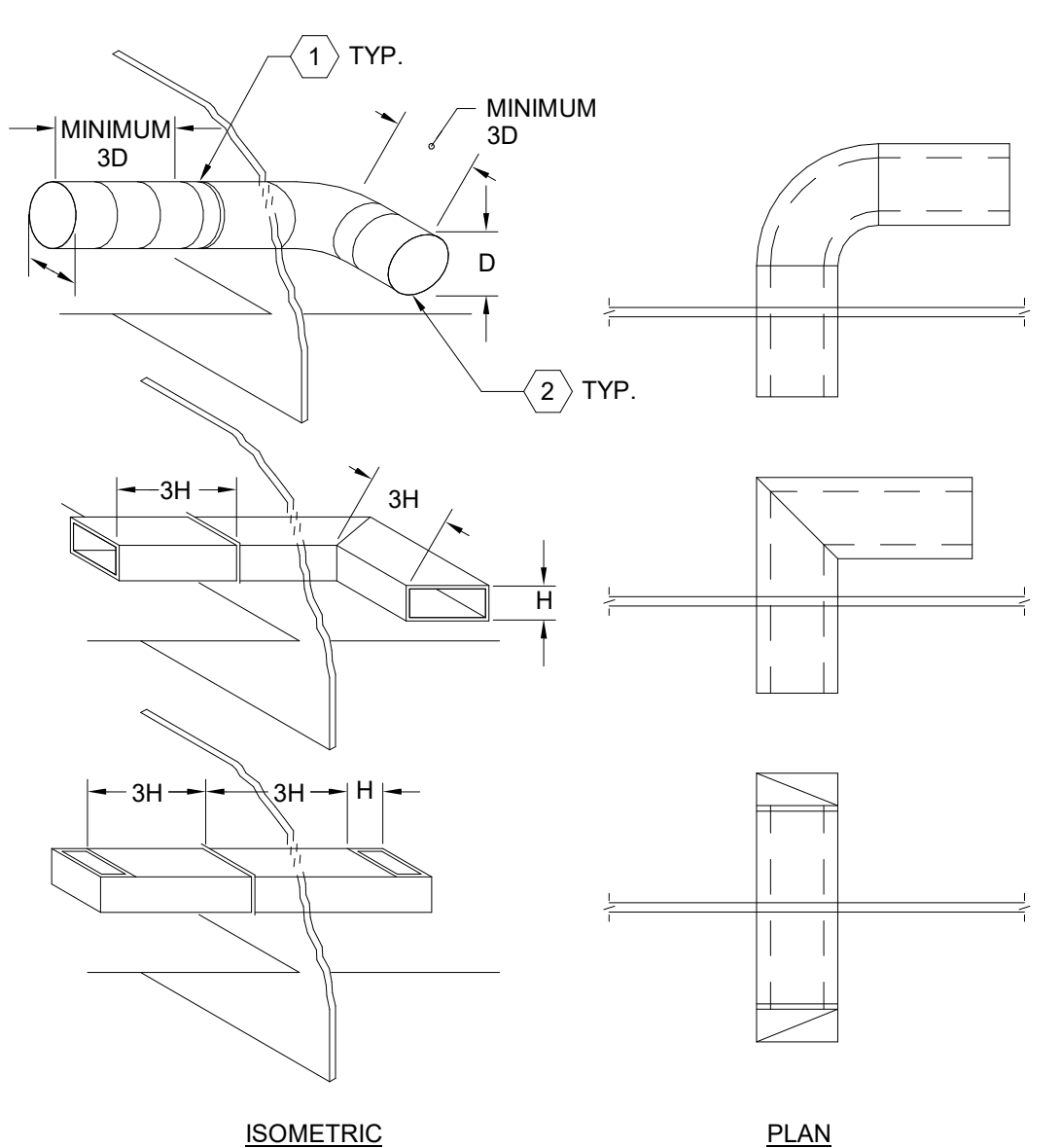

NOTE:
 A. SHALL BE USED ON ALL DUCTS UPSTREAM OF TERMINAL UNITS.

6 ACOUSTIC AIR TRANSFER DUCT DETAILS

NO SCALE

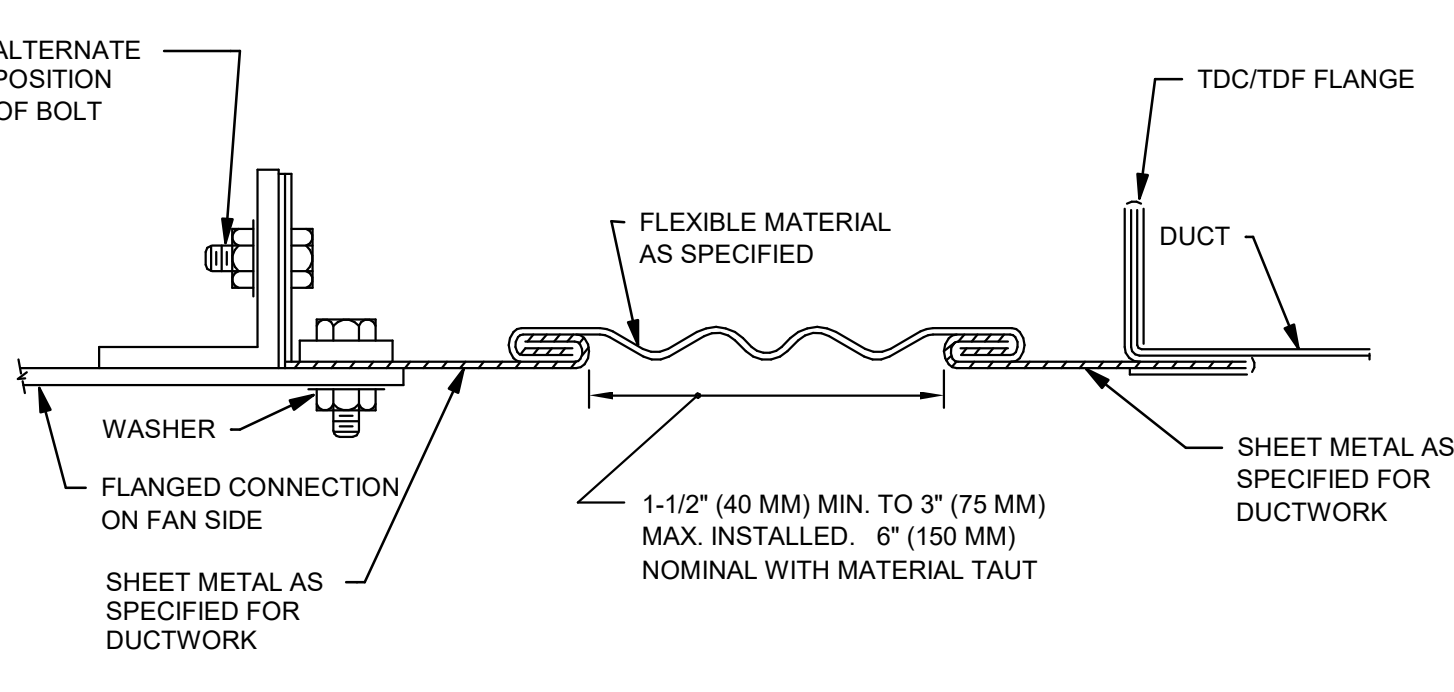

RECTANGULAR FLEXIBLE CONNECTION

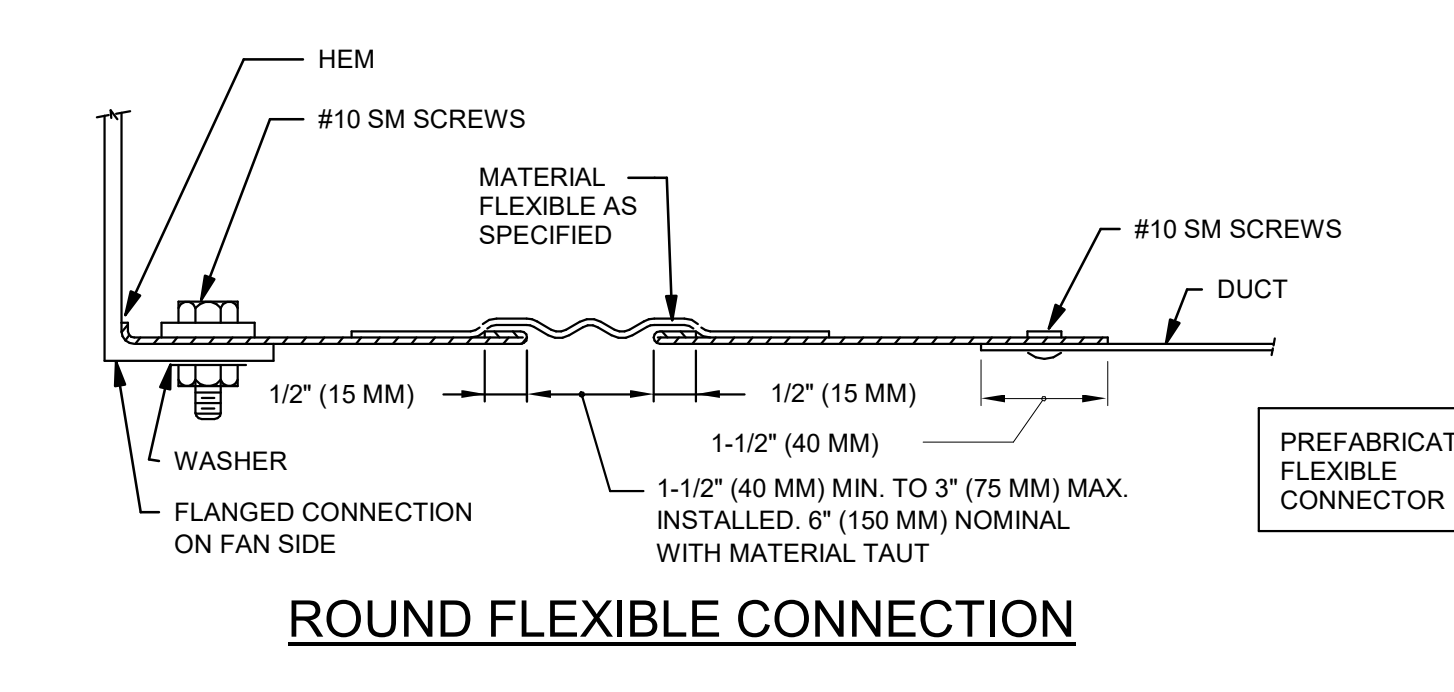

10 TYPICAL TERMINAL UNIT DUCTING (VAV OR CAV)

NO SCALE

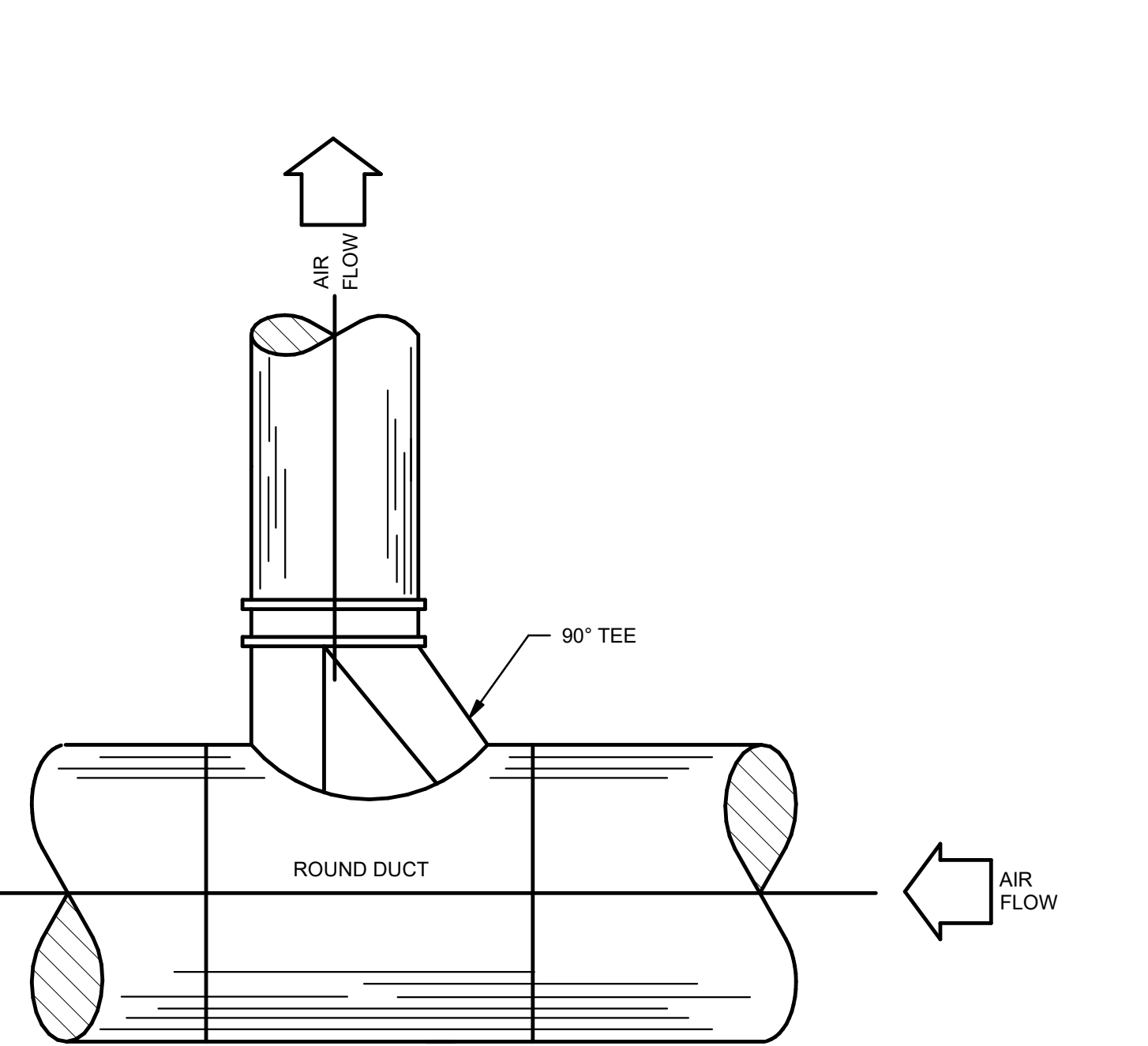

11 CEILING FIRE RADIATION DAMPER

NO SCALE

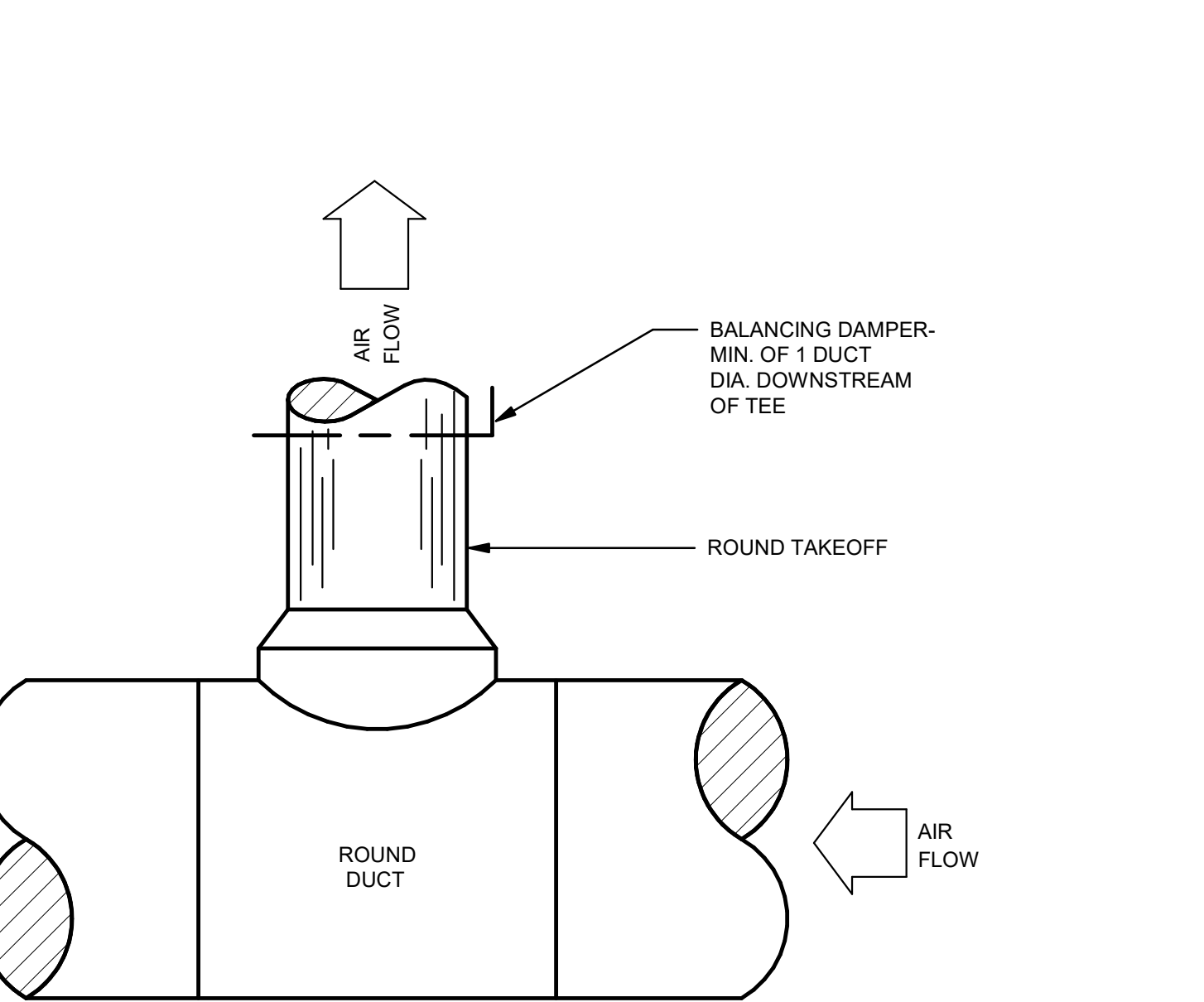

12 FIRE & SMOKE DAMPER

NO SCALE

9 MEDIUM PRESSURE DUCT TAP - CONICAL TEE

NO SCALE

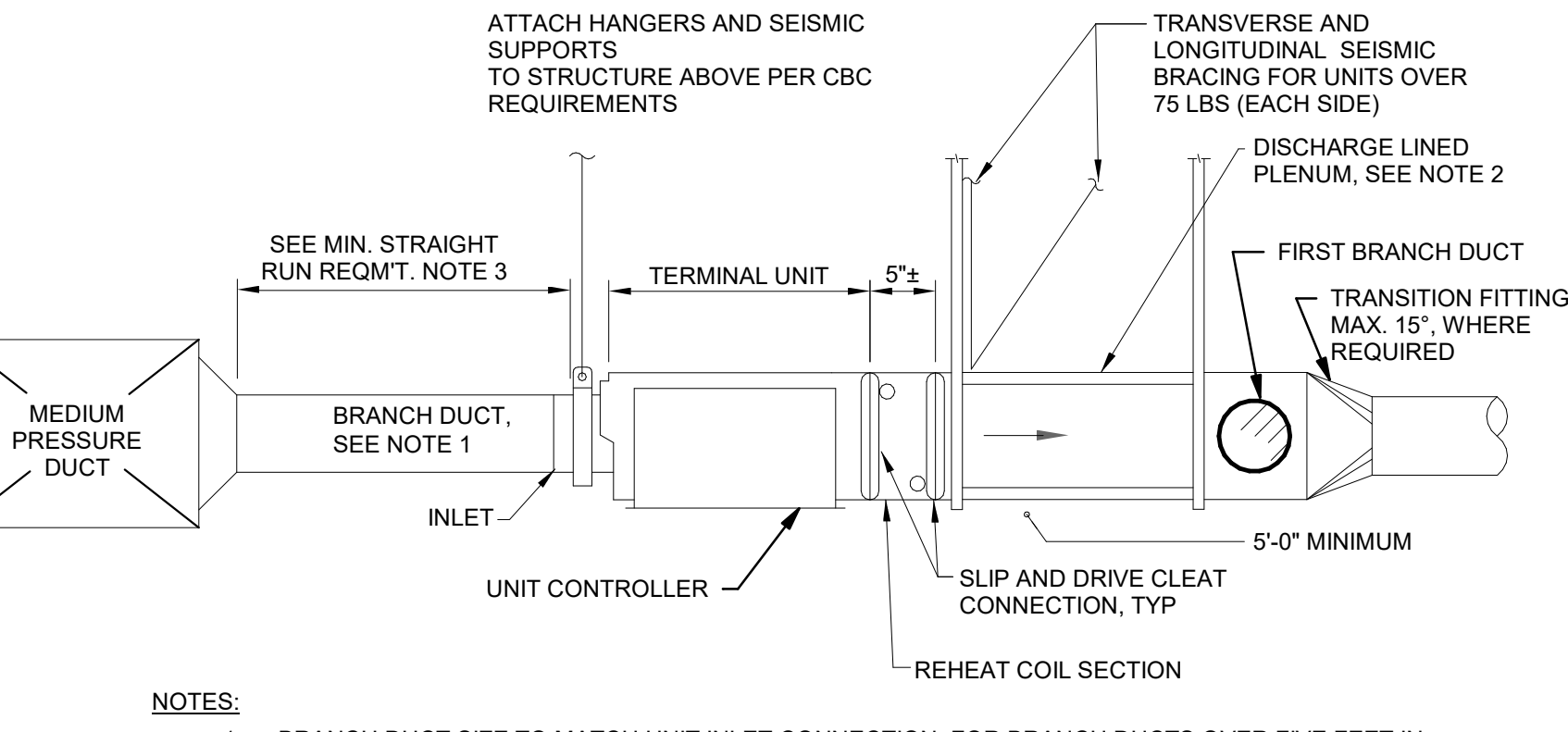

10 TYPICAL TERMINAL UNIT DUCTING (VAV OR CAV)

NO SCALE

NOTES:
 1. BRANCH DUCT SIZE TO MATCH UNIT INLET CONNECTION. FOR BRANCH DUCTS OVER FIVE FEET IN LENGTH, INCREASE BRANCH DUCT ONE SIZE AND PROVIDE TRANSITION IMMEDIATELY UPSTREAM OF MINIMUM STRAIGHT DUCT RUN.
 2. MINIMUM 5'-0" LONG LINED PLENUM EQUAL TO TERMINAL BOX OUTLET SIZE. PROVIDE WITH MYLAR LINING FOR OSHPD PROJECTS.
 3. MINIMUM STRAIGHT DUCT RUN SHALL BE EQUAL TO 4 TIMES THE INLET DIAMETER OF TERMINAL UNIT.
 4. FIRST BRANCH DUCT DOWNSTREAM OF TERMINAL MUST BE A MINIMUM OF 5 FEET DOWNSTREAM OF TERMINAL UNIT.

VERIFY SCALE

BAR IS ONE (1) INCH LONG ON ORIGINAL DRAWING: 0 1
 IF BAR IS NOT ONE (1) INCH LONG, ADJUST SCALE ACCORDINGLY

CONTRACTOR SHALL FIELD VERIFY ALL DIMENSIONS. VARIANCE FROM CONTRACT DOCUMENTS NOT PERMITTED WITHOUT PROFESSIONAL & BUREAU OF CONSTRUCTION APPROVAL.

SHEET No. **MAQ-M-700**

DRAWN BY: Author CHECKED BY: Checker DATE: SCALE: AS NOTED

TACTICAL TRAINING DESIGN

Tactical Design North, Inc.
 231 E. Buffalo St #502, Milwaukee, WI 53202

LOCAL ARCHITECT
Jacobs Wyper Architects
 1232 Chancellor St, Philadelphia, PA 19107

STRUCTURAL ENGINEER
Skidmore, Owings & Merrill LLP
 250 Greenwich St, New York, NY 10007

ELECTRICAL, PLUMBING, FIRE PROTECTION, FIRE ALARM ENGINEER
A & J Consulting Engineering Services, P.C.
 164 Brighton Rd, Clifton, NJ 07012

MECHANICAL AVIT ENGINEER
Interface Engineering, Inc.
 2000 M Street NW, Suite 270, Washington, DC 20036

ACOUSTICAL ENGINEER
Cerami
 1001 Ave of the Americas, 4th Floor, New York, NY 10018

CODE CONSULTING
CCI
 215 W 40th St, 10th Floor, New York, NY 10018

CIVIL ENGINEER
Langan
 1818 Market St #3300, Philadelphia, PA 19103

VERTICAL TRANSPORT
Michael Blades & Associates Ltd.
 5409 Rapiand Ct, Lothian, MD 20711

SIGNAGE CONSULTANT
Patricia Hord Graphik Design
 119 S. St. Asaph St, Alexandria, VA 22314

LANDSCAPE
Lee and Associates, Inc.
 6381 I Street NW, Washington, DC 20001

LIGHTING
MCLA
 1000 Potomac St NW, Suite 121, Washington, DC 20007

FOOD SERVICE
Hopkins Foodservice Specialists, Inc.
 7906 MacArthur Blvd, Suite 100, Cabin John, MD 20818

POOL DESIGN
Aqua Design International
 7536 N. La Cholla Blvd Tucson, AZ 85741

KEYPLAN

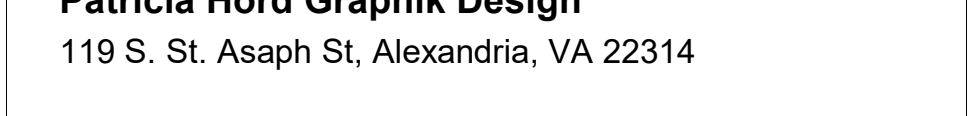

NO.	DATE	DESCRIPTION	NO.	DATE	DESCRIPTION
1	29 JUN 2023	ADDENDUM 29			
2	19 MAY 2023	ISSUED FOR BID			

RECORD REVISIONS

SIGNATURE DATE

ARCHITECT **SOM**
 Skidmore, Owings & Merrill LLP
 250 Greenwich St, New York, 10007

COMMONWEALTH OF PENNSYLVANIA
 DEPARTMENT OF GENERAL SERVICES
 HARRISBURG, PENNSYLVANIA

D.G.S. PROJECT No. **C-0211-0005 PHASE 6**

Pennsylvania State Police Academy
 Outbuildings, Tactical Villages & Sitework
 PENNSYLVANIA STATE POLICE
 HERSHEY, DAUPHIN COUNTY, PA

AIRSIDE DETAILS

CONTRACTOR SHALL FIELD VERIFY ALL DIMENSIONS. VARIANCE FROM CONTRACT DOCUMENTS NOT PERMITTED WITHOUT PROFESSIONAL & BUREAU OF CONSTRUCTION APPROVAL.

SHEET No. **MAQ-M-700**

DRAWN BY: Author CHECKED BY: Checker DATE: SCALE: AS NOTED

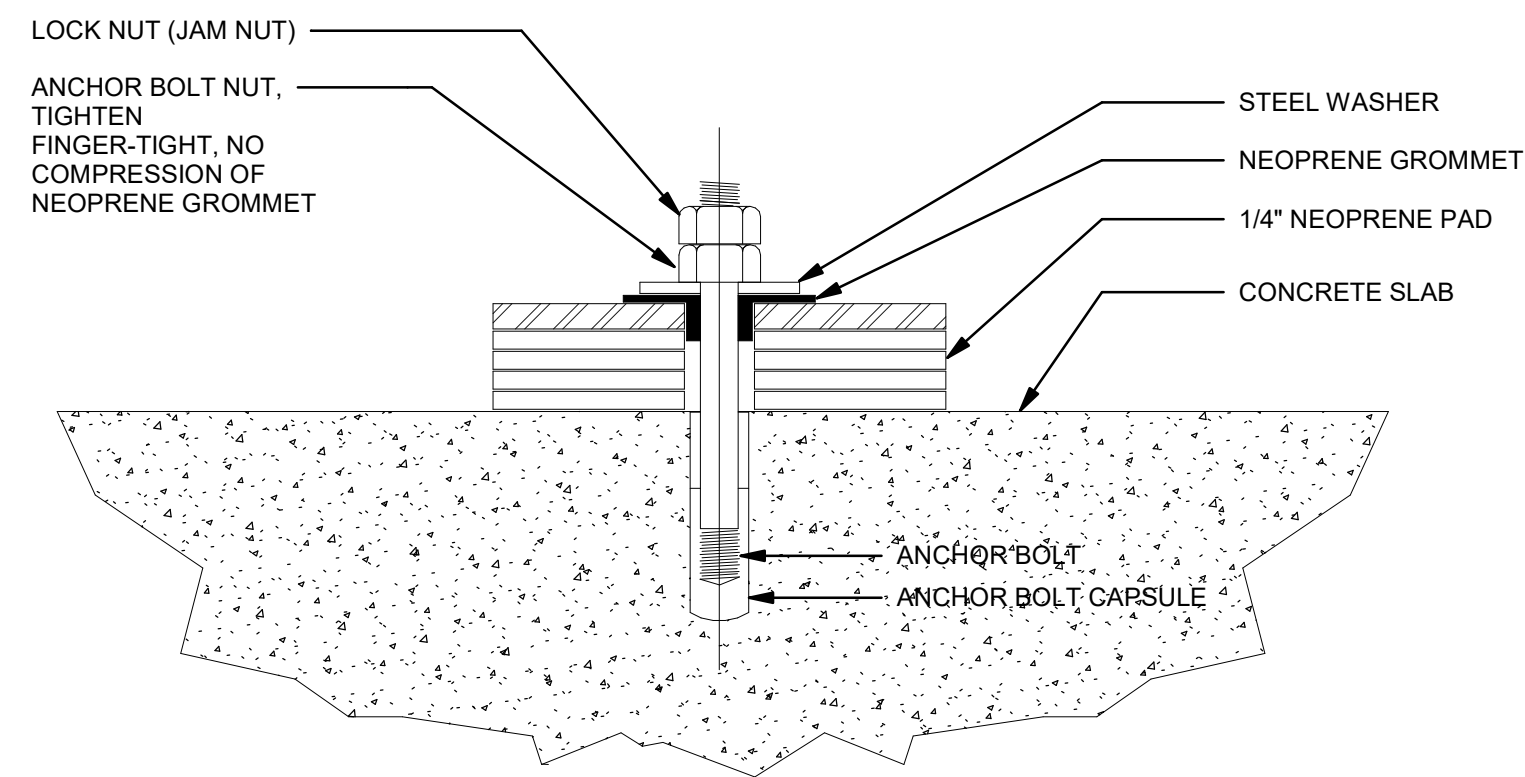

1 EQUIPMENT ANCHORAGE

NO SCALE

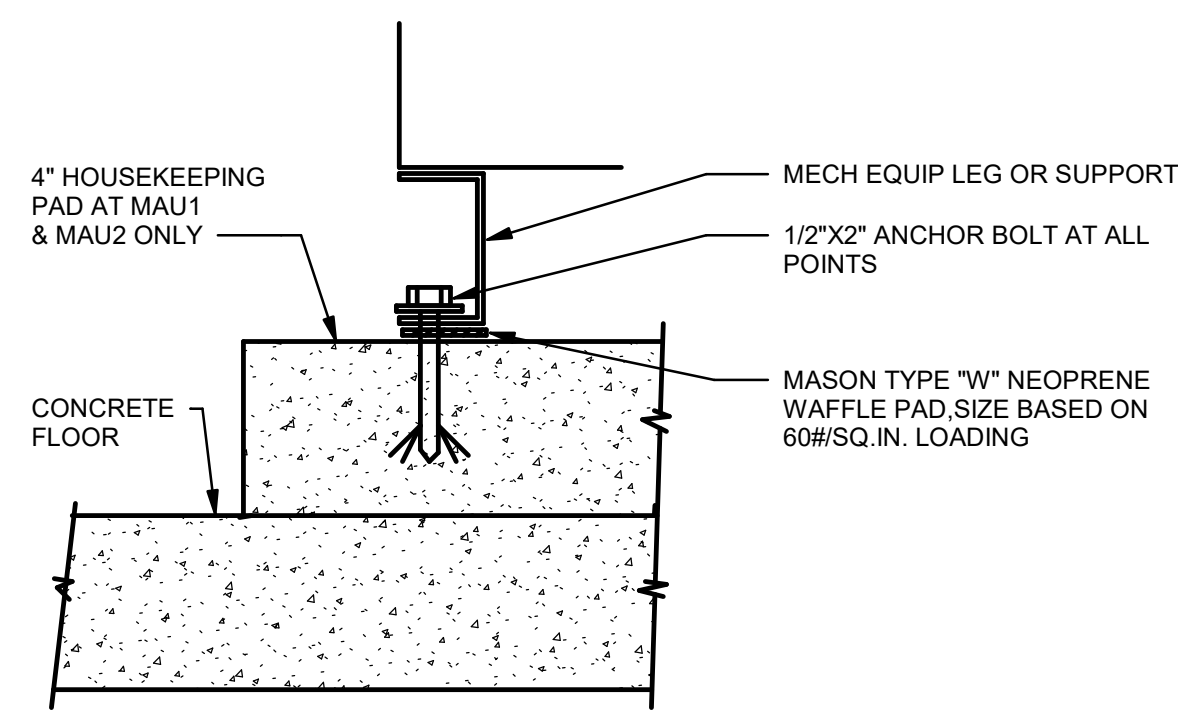

2 EQUIPMENT ATTACHMENT W/O ISOLATORS

NO SCALE

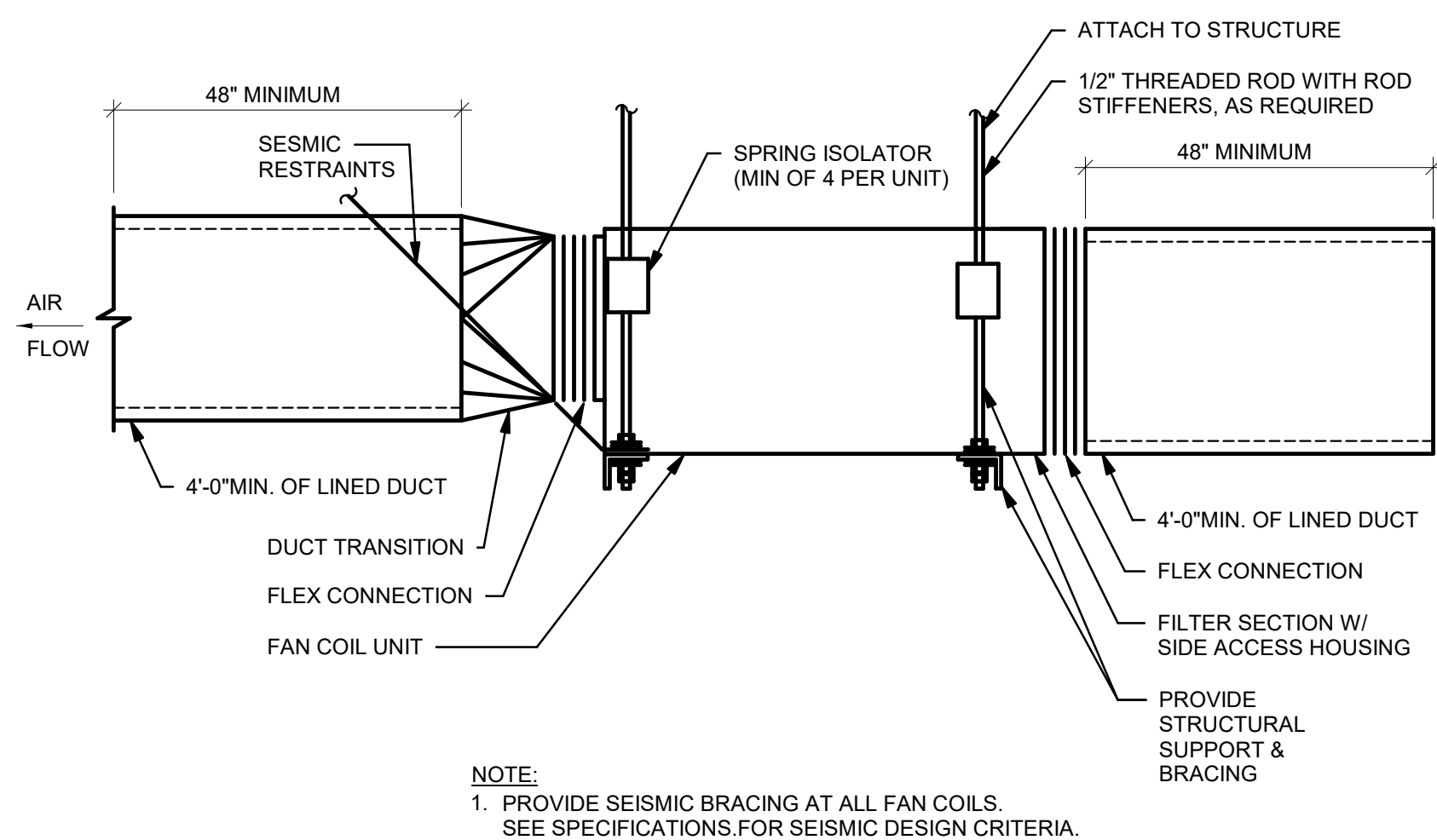

3 FAN COIL UNIT HANGING DETAIL (FC-x)

NO SCALE

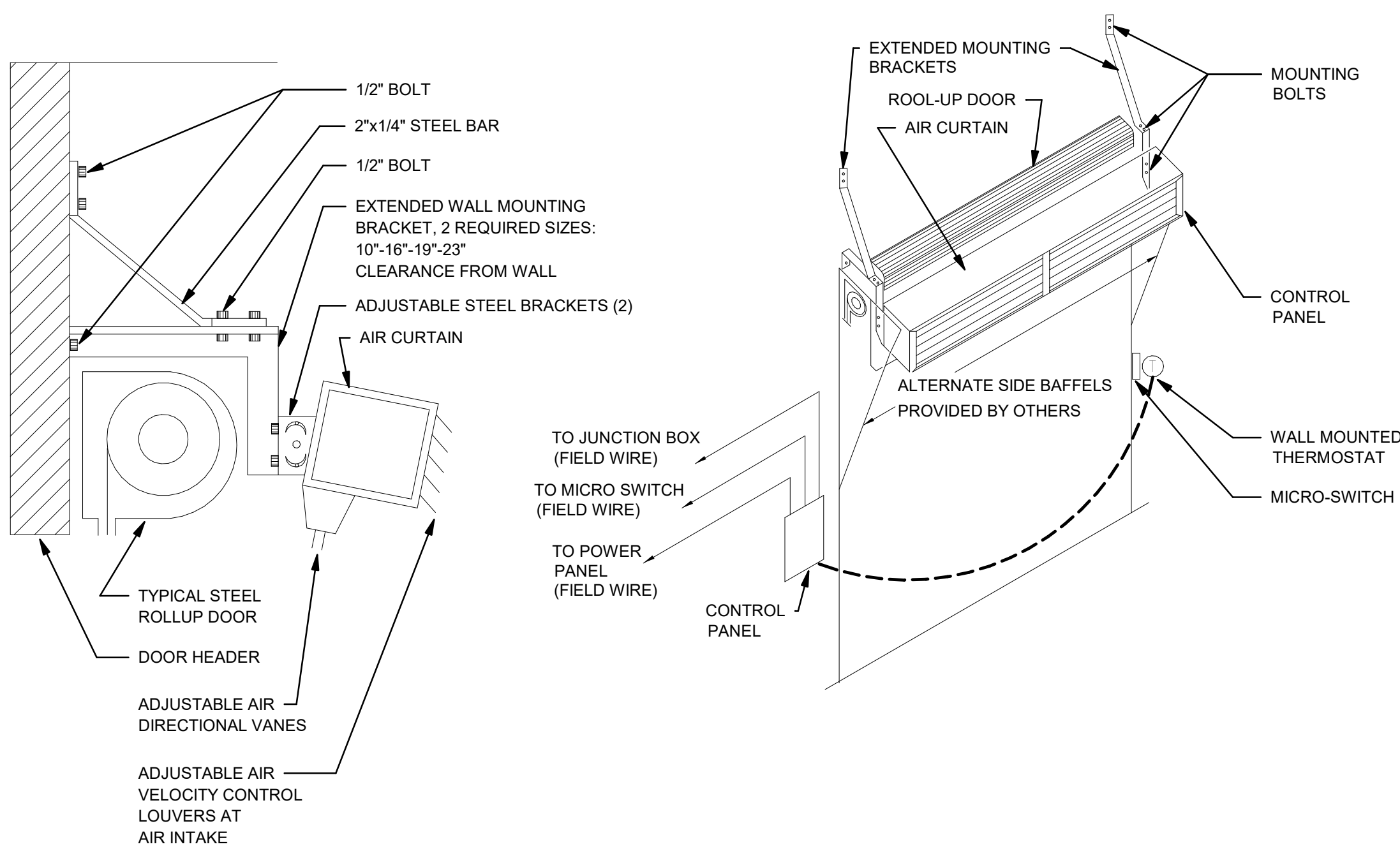

4 AIR CURTAIN MOUNTING

NO SCALE

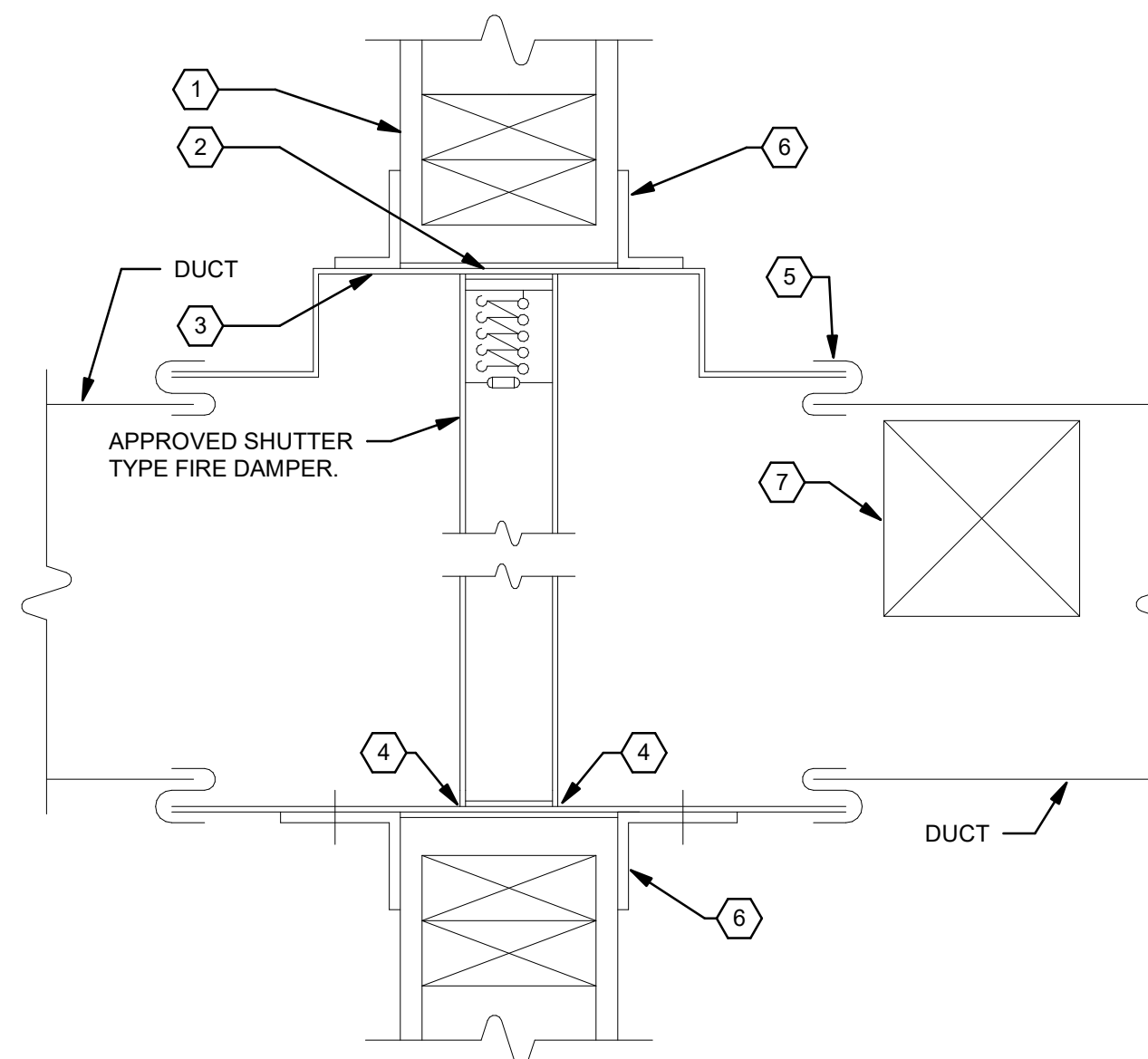

5 FIRE DAMPER

NO SCALE

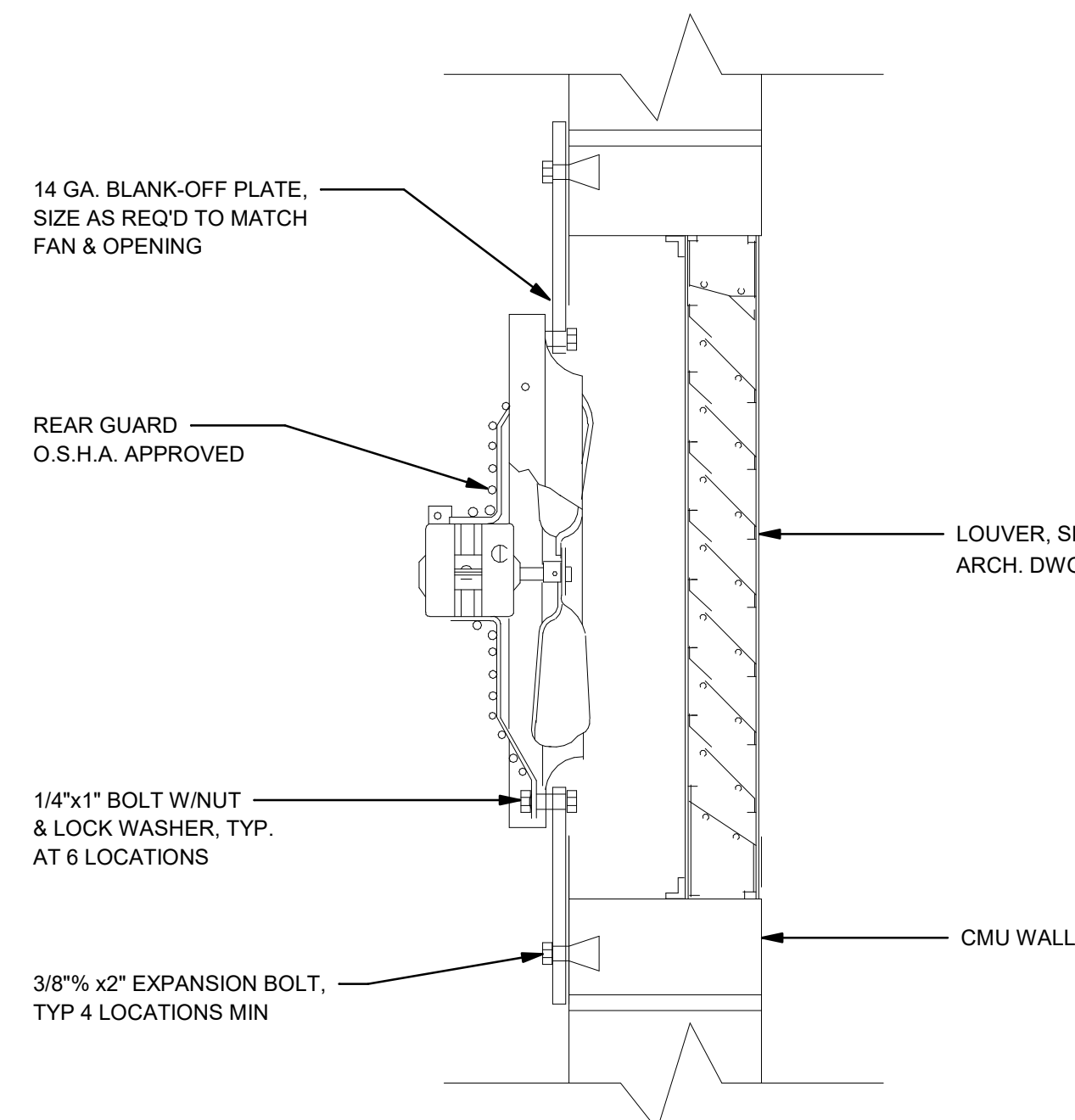

6 WALL MOUNTED EXHAUST FAN

NO SCALE

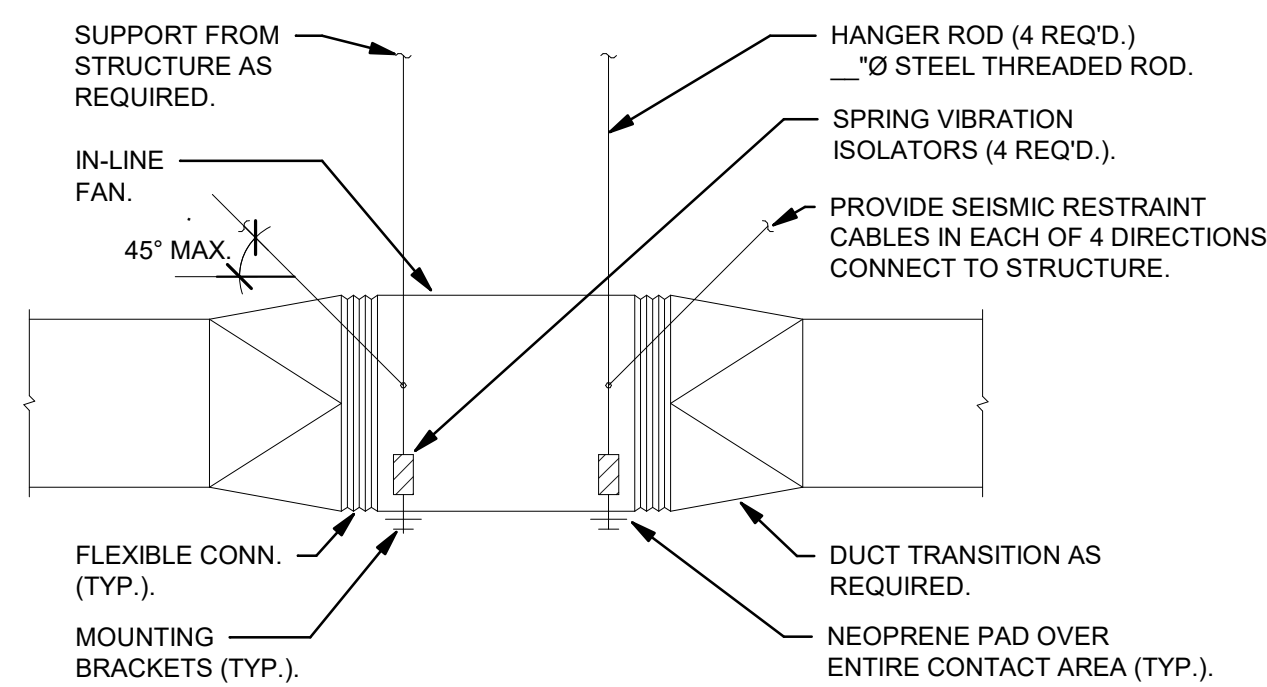

7 IN-LINE FAN

NO SCALE

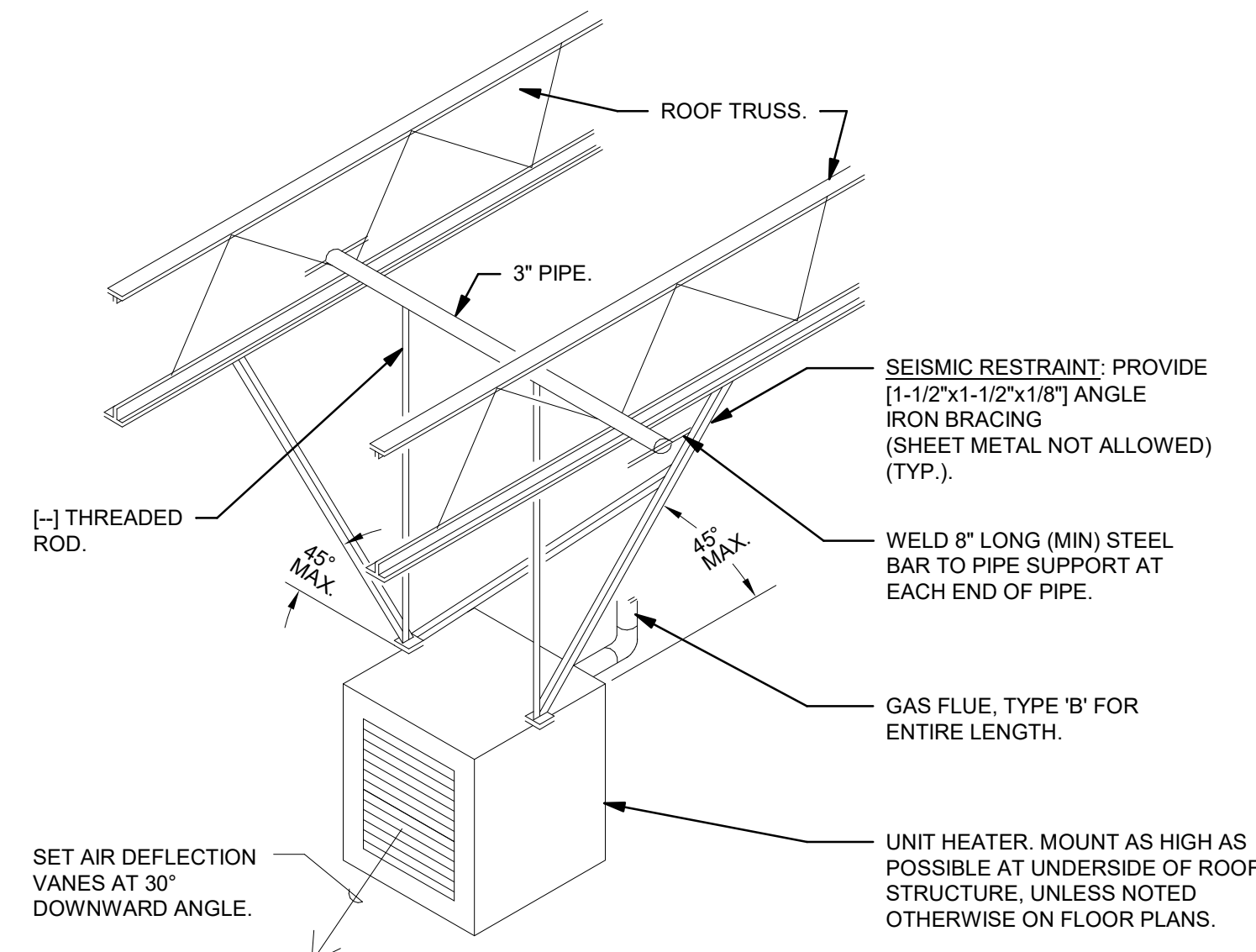

8 UNIT HEATER INSTALLATION

NO SCALE

- NOTES:**
- 1 FIRE RATED PARTITION. COORDINATE WITH ARCHITECTURAL FOR FRAMING AND FIRE RATED LINING REQUIREMENTS.
 - 2 COORDINATE PARTITION OPENING, 1/8" LARGER THAN FIRE DAMPER SLEEVE PER FOOT OF WIDTH OR HEIGHT.
 - 3 PROVIDE SLEEVE 3" BEYOND EDGE OF PARTITION, EACH SIDE.
 - 4 FIRE DAMPER FRAME ATTACHED TO SLEEVE BY MANUFACTURER.
 - 5 "S" TYPE DUCT CONNECTION. DO NOT SCREW OR BOLT.
 - 6 ANGLE ALL AROUND SLEEVE MINIMUM 1" OVERLAP WITH WALL FRAMING. ONE INCH FILLET WELDS 5" MAX. ON CENTER, OR 1/4" BOLTS 5" MAX. ON CENTER. DO NOT ATTACH ANGLES TO WALL. COORDINATE WITH DAMPER MANUFACTURER FOR APPROVED ANGLE SIZE AND GAUGE.
 - 7 PROVIDE DUCT ACCESS DOOR. COORDINATE LOCATION AND TYPE OF ARCHITECTURAL SERVICE ACCESS WITH ARCHITECTURAL.
- GENERAL NOTES:**
DETAIL INDICATES REQUIREMENTS FOR STANDARD FRAME INSTALLATION. REFERENCE "SMACNA FIRE, SMOKE AND RADIATION DAMPER INSTALLATION GUIDE" FOR OTHER CONFIGURATION REQUIREMENTS. COMPLY FULLY WITH ABOVE MENTIONED AND ALSO AHJ REQUIREMENTS IN ALL CASES.

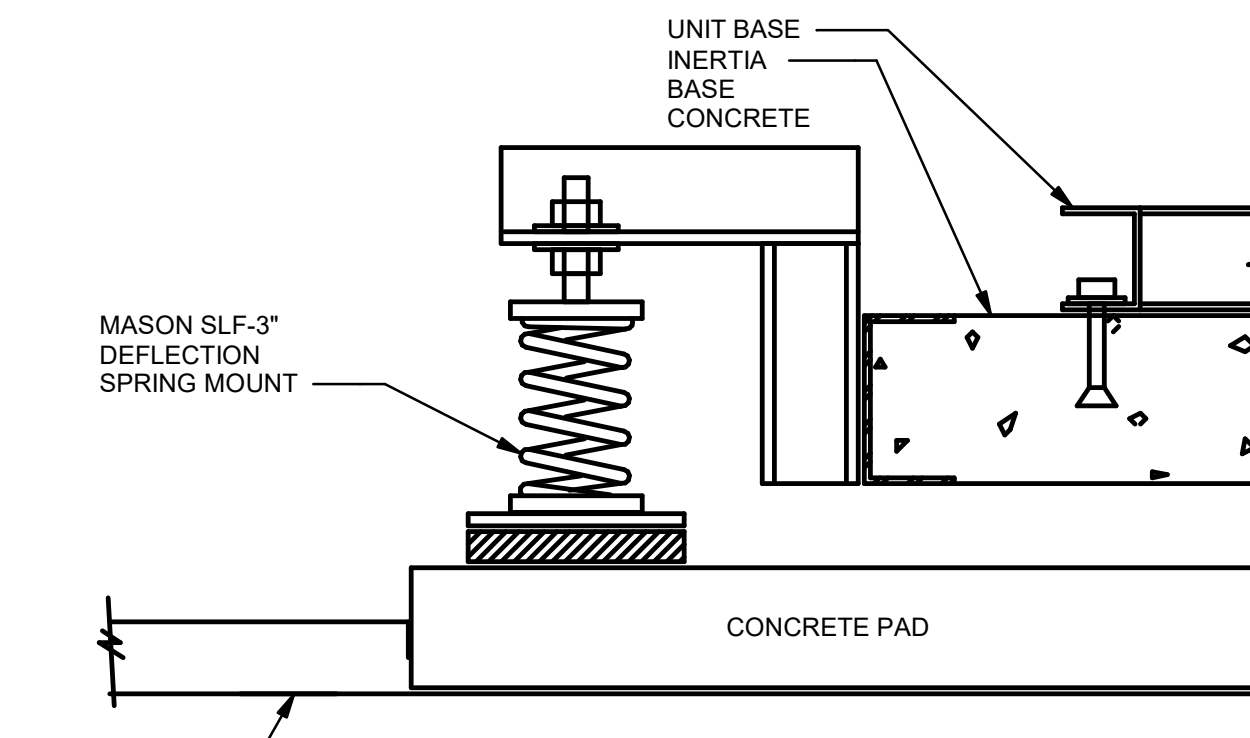

NOTE:
PROVIDE MASON Z-1225 SEISMIC SNUBBER - MIN 4

9 INERTIA BASE SUPPORT DETAIL

NO SCALE

TACTICAL TRAINING DESIGN

Tactical Design North, Inc.
231 E. Buffalo St #502, Milwaukee, WI 53202

LOCAL ARCHITECT

Jacobs Wyper Architects
1232 Chancellor St, Philadelphia, PA 19107

STRUCTURAL ENGINEER

Skidmore, Owings & Merrill LLP
250 Greenwich St, New York, NY 10007

ELECTRICAL, PLUMBING, FIRE PROTECTION, FIRE ALARM ENGINEER

A & J Consulting Engineering Services, P.C.
164 Brighton Rd, Clifton, NJ 07012

MECHANICAL, AVIT ENGINEER

Interface Engineering, Inc.
2000 M Street NW, Suite 270, Washington, DC 20036

ACOUSTICAL ENGINEER

Cerami
1001 Ave of the Americas, 4th Floor, New York, NY 10018

CODE CONSULTING

CCI
215 W 40th St, 10th Floor, New York, NY 10018

CIVIL ENGINEER

Langan
1818 Market St #3300, Philadelphia, PA 19103

VERTICAL TRANSPORT

Michael Blades & Associates Ltd.
5409 Rapidan Ct, Lothian, MD 20711

SIGNAGE CONSULTANT

Patricia Hord Graphik Design
119 S. St. Asaph St, Alexandria, VA 22314

LANDSCAPE

Lee and Associates, Inc.
638 I Street NW, Washington, DC 20001

LIGHTING

MCLA
1000 Potomac St NW, Suite 121, Washington, DC 20007

FOOD SERVICE

Hopkins Foodservice Specialists, Inc.
7906 MacArthur Blvd, Suite 100, Cabin John, MD 20818

POOL DESIGN

Aqua Design International
7536 N. La Cholla Blvd Tucson, AZ 85741

KEYPLAN

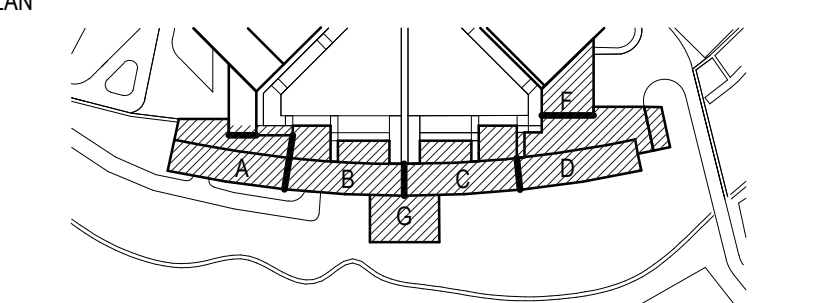

NO.	DATE	DESCRIPTION	NO.	DATE	DESCRIPTION
1	29 JUN 2023	ADDENDUM 29			
2	19 MAY 2023	ISSUED FOR BID			
RECORD REVISIONS					

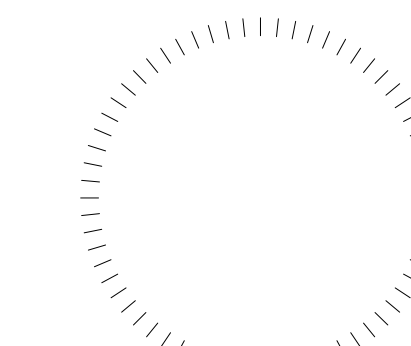

SIGNATURE DATE

ARCHITECT

SOM
Skidmore, Owings & Merrill LLP
250 Greenwich St, New York, 10007

COMMONWEALTH OF PENNSYLVANIA
DEPARTMENT OF GENERAL SERVICES
HARRISBURG, PENNSYLVANIA

D.G.S. PROJECT No. C-0211-0005 PHASE 6

Pennsylvania State Police Academy
Outbuildings, Tactical Villages & Sitework
PENNSYLVANIA STATE POLICE
HERSHEY, DAUPHIN COUNTY, PA

VERIFY SCALE

BAR IS ONE (1) INCH LONG
ON ORIGINAL DRAWING:
0 1

IF BAR IS NOT ONE (1) INCH LONG,
ADJUST SCALE ACCORDINGLY

CONTRACTOR SHALL FIELD VERIFY ALL DIMENSIONS. VARIANCE FROM CONTRACT DOCUMENTS NOT PERMITTED WITHOUT PROFESSIONAL & BUREAU OF CONSTRUCTION APPROVAL.

SHEET No.

MAQ-M-701

DRAWN BY

Author

CHECKED BY

Checker

DATE

SCALE

AS NOTED

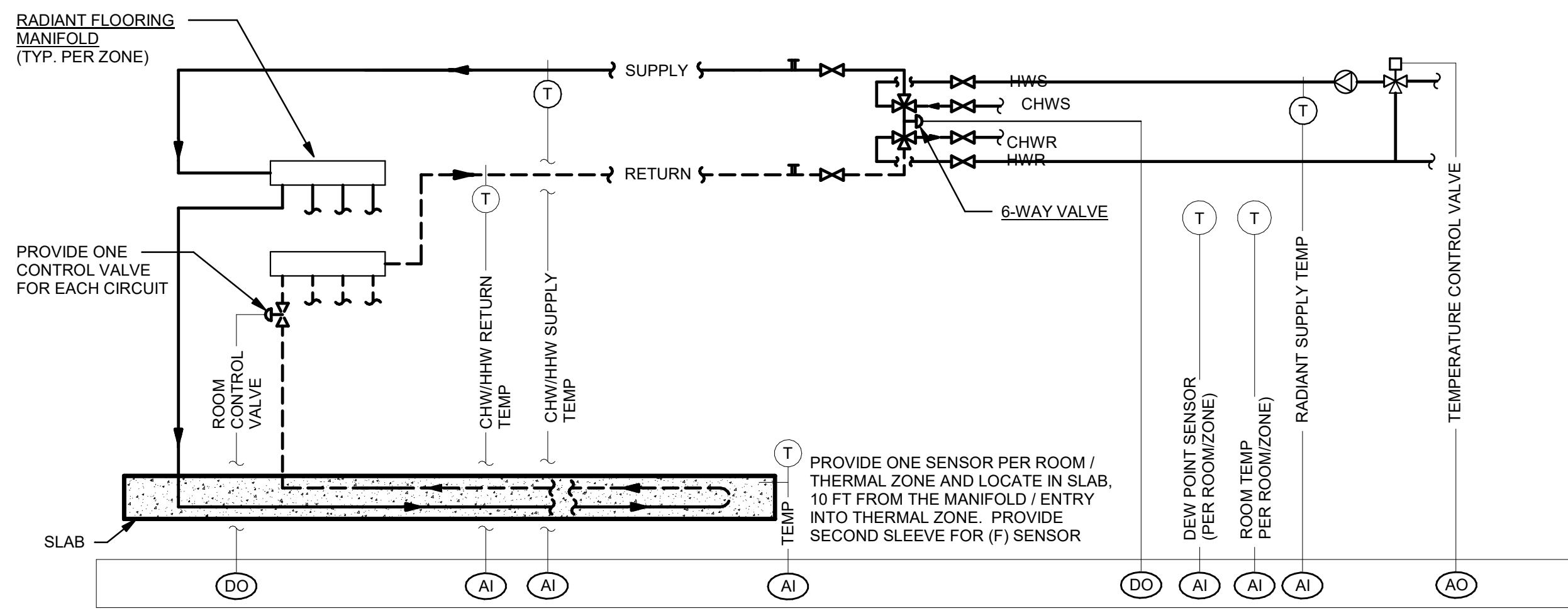

- GENERAL
 - MAINTAIN SLAB TEMPERATURE AT CORRESPONDING SETPOINT TEMPERATURES AT ALL TIMES, EXCEPT AS NOTED DURING UNOCCUPIED PERIODS. REFER TO UNOCCUPIED MODE SEQUENCE BELOW.
 - EXCEPT AS NOTED FOR MORNING COOL-DOWN MODE, AT ALL OPERATING MODES, MAINTAIN SLAB TEMPERATURE AT NOT LESS THAN 62 DEGREES F (ADJ.), NOT MORE THAN 80 DEGREES F (ADJ.), AND 2 DEGREES F (ADJ.) WARMER THAN INDOOR DEW POINT TEMP DURING OCCUPIED HOURS. GENERATE AN ALARM IF SLAB TEMPERATURE IS BEYOND SETPOINTS INDICATED.
 - USE PID CONTROL LOOPS TO RESET SLAB SETPOINT TEMPERATURE BASED ON CURRENT SPACE TEMPERATURE SETPOINT AND RATE OF CHANGE OF SPACE TEMPERATURE, AND UPCOMING SPACE TEMPERATURE SETPOINT (IE CHANGE OF OCCUPANCY MODE FROM UNOCCUPIED TO OCCUPIED).
 - COMMISSIONING AGENT, TAB TECHNICIAN SHALL BE PRESENT DURING THE COMMISSIONING PERIOD AND PROVIDE INPUT FOR CORRECT SETTING OF PID LOOP PARAMETERS.
- UNOCCUPIED MODE
 - RESET SLAB TEMPERATURE SETPOINT TO 70 DEGREES F (ADJ) WITH A DEADBAND OF 2 DEGREES F. RESET SPACE TEMPERATURE SETPOINT TO SET-BACK TEMPERATURE. IGNORE SPACE CO2 SIGNALS. CLOSE TERMINAL UNIT DAMPER, AND OPEN CONTROL VALVE(S) TO HEATING HOT WATER OR CHILLED WATER FLOW, AS REQUIRED TO MAINTAIN SLAB TEMPERATURE SETPOINT.
- MORNING WARM-UP
 - INITIATE MORNING WARM-UP MODE USING AN OPTIMAL START ALGORITHM THAT USES AN ADAPTIVE LEARNING FEATURE THAT AUTOMATICALLY ADJUSTS THE MORNING WARM-UP START TIME SO THAT THE AVERAGE ZONE TEMPERATURE IN THE EXTERIOR ZONES IS 88 DEGREES F (ADJ.) AT THE START OF SCHEDULED OCCUPIED PERIOD. RESET SLAB TEMPERATURE SETPOINT AS DETERMINED BY PID CONTROL LOOP AND OPEN CONTROL VALVE(S) TO HEATING HOT WATER FLOW, AS REQUIRED TO MAINTAIN SLAB SPACE TEMPERATURE SETPOINT. CLOSE TERMINAL UNIT DAMPER.
- MORNING COOL-DOWN
 - INITIATE MORNING COOL-DOWN MODE USING AN OPTIMAL START ALGORITHM THAT USES AN ADAPTIVE LEARNING FEATURE THAT AUTOMATICALLY ADJUSTS THE MORNING COOL-DOWN START TIME SO THAT THE AVERAGE ZONE TEMPERATURE IN THE EXTERIOR ZONES IS 72 DEGREES F (ADJ.) AT THE START OF SCHEDULED OCCUPIED PERIOD. RESET SLAB TEMPERATURE SETPOINT TO 80 DEGREES F (ADJ.). OPEN 6-WAY VALVE TO CHILLED WATER FLOW, AS REQUIRED TO MAINTAIN SLAB TEMPERATURE SETPOINT. CLOSE TERMINAL UNIT DAMPER, AT A TIME PERIOD DETERMINED BY PID LOOP. LOCK OUT CHILLED WATER FLOW SO THAT SLAB TEMPERATURE REACHES 65 DEGREES F (ADJ.) 30 MINUTES (ADJ.) AFTER START OF OCCUPANCY, AT WHICH POINT REMOVE CHILLED WATER FLOW LOCKOUT.
- OCCUPIED MODE
 - RESET SLAB TEMPERATURE SETPOINT AS DETERMINED BY PID CONTROL LOOP AND OPEN CONTROL VALVE(S) TO HEATING HOT WATER OR CHILLED WATER FLOW, AS REQUIRED TO MAINTAIN SLAB SPACE TEMPERATURE SETPOINT.
 - FOR SPACES WITH CO2 SENSORS:
 - FOR ZONES WITH CO2 SENSORS, IF SPACE CO2 CONCENTRATION IS GREATER THAN 450 PPM (ADJ.) ABOVE OUTDOOR CO2 LEVEL, MODULATE DAMPER BETWEEN MINIMUM HEATING AND MAXIMUM HEATING AIRFLOW SETPOINTS TO MAINTAIN MAXIMUM CO2 CONCENTRATION OF 800 PPM (ADJ.) ABOVE OUTDOOR CO2 LEVEL. GENERATE AN ALARM IF THE ZONE CO2 CONCENTRATION IS GREATER THAN 800 PPM (ADJ.) ABOVE OUTDOOR CO2 LEVEL. PROVIDE ADEQUATE DELAY (TIME DETERMINED DURING COMMISSIONING) TO AVOID FALSE ALARMING AND ADEQUATE TIME FOR SYSTEM TO BALANCE DURING SUDDEN LOADING OF SPACES.
 - FOR SPACES WITHOUT CO2 SENSORS:
 - OPERATE TERMINAL UNIT AND SET SUPPLY AIR QUANTITY AT MINIMUM HEATING CFM AND MODULATE TERMINAL UNIT HEATING HOT WATER CONTROL VALVE TO MAINTAIN SPACE TEMPERATURE.
- STANDBY MODE
 - STANDBY MODE APPLIES TO FOLLOWING ROOM/AREA TYPES, ONLY:
 - GENERAL
 - PUBLIC ASSEMBLY SPACE
 - LOBBIES
 - INITIATE STANDBY MODE IF ALL NORMALLY OCCUPIED SPACES SERVED BY THE UNIT ARE PROVIDED WITH OCCUPANCY SENSORS. ENTER STANDBY MODE IF THE OCCUPANCY SENSORS IN ALL ROOMS SERVED BY THE TERMINAL UNIT DO NOT DETECT OCCUPANCY FOR 5 MINUTES (ADJ.).
 - DURING STANDBY MODE:
 - RESET COOLING TEMPERATURE SETPOINT TO 3 DEGREES F (ADJ.) ABOVE NORMAL OCCUPIED SETPOINT AND HEATING TEMPERATURE SETPOINT TO 3 DEGREES F (ADJ.) BELOW NORMAL OCCUPIED HEATING SETPOINT AND CLOSE TERMINAL UNIT'S DAMPER.
 - WHEN OCCUPANCY IS DETECTED IN ANY SPACE SERVED BY THE UNIT, UNOCCUPANCY OVERRIDE SWITCH HAS BEEN ACTIVATED, OR THERE IS A CHANGE IN THE MODE OF THE SYSTEM, TERMINATE STANDBY MODE AND RESET ALL ALUES TO THEIR ORIGINAL SETPOINTS.
- ALARMS
 - GENERATE AN ALARM IF DAMPERS ARE COMMANDED OPEN/CLOSED OR TO MODULATE BUT DO NOT SEND FEEDBACK OF PROPER POSITION.
 - GENERATE AN ALARM UPON SENSING OF CONDENSATION AND LOCK OUT COOLING WATER FLOW AT THE CHILLED WATER 6-WAY CONTROL VALVE.

1 RADIANT SLAB CONTROL DIAGRAM

NO SCALE

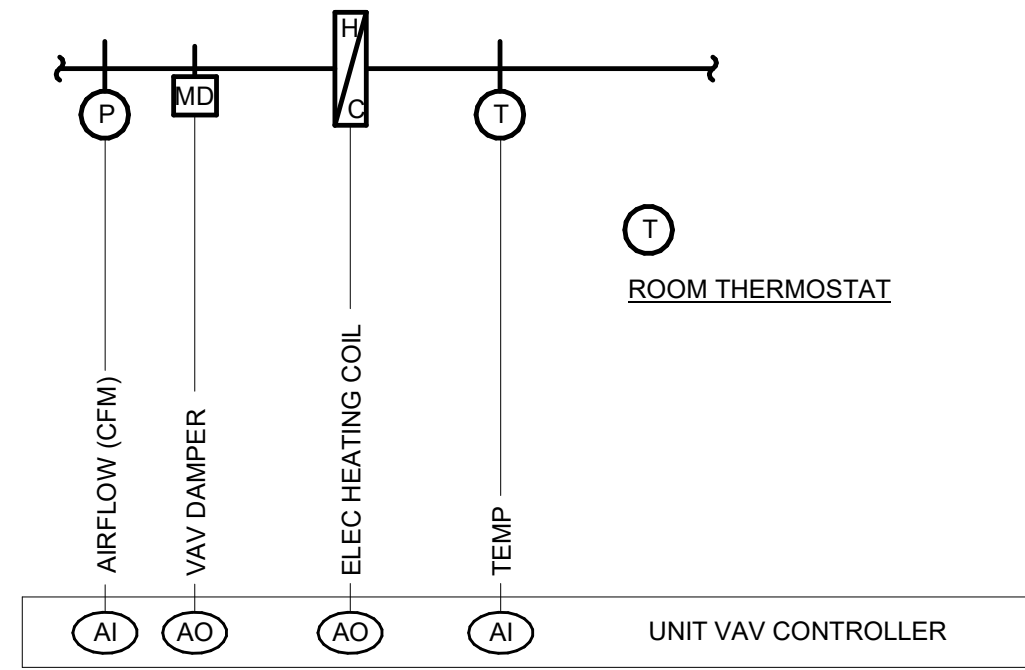

- TERMINAL UNIT CONTROLLER RECEIVES SIGNAL FROM BUILDING CONTROLLER WHICH INITIATES OCCUPIED OR UNOCCUPIED MODE. DURING UNOCCUPIED MODE SPACE TEMPERATURE RESET TO UNOCCUPIED SETPOINTS AND DURING OCCUPIED MODE SPACE TEMPERATURE RESETS TO OCCUPIED SETPOINTS. WHEN ENTERING OCCUPIED MODE, USE AN OPTIMAL START ALGORITHM FOR WARM-UP OR COOL-DOWN. MINIMIZE THE WARM-UP OR COOL-DOWN PERIOD WHILE STILL ACHIEVING COMFORT CONDITIONS BY THE START OF SCHEDULED OCCUPIED PERIOD.
- UNOCCUPIED MODE
 - TERMINAL UNIT DAMPER CLOSED. IGNORE ANY SIGNALS FROM SPACE OCCUPANCY OR CARBON DIOXIDE SENSORS.
 - IF SPACE TEMPERATURE IS GREATER THAN UNOCCUPIED COOLING SETPOINT, AND IF CENTRAL AIR HANDLING UNIT SUPPLY FAN IS RUNNING, MODULATE DAMPER BETWEEN MINIMUM AND MAXIMUM COOLING AIRFLOW SETPOINTS TO MAINTAIN SPACE TEMPERATURE AT UNOCCUPIED COOLING SETPOINT.
- OCCUPIED MODE
 - MODULATE DAMPER TO MAINTAIN MINIMUM AIRFLOW SETPOINT.
 - IF SPACE TEMPERATURE IS GREATER THAN OCCUPIED COOLING SETPOINT, MODULATE DAMPER BETWEEN MINIMUM AND MAXIMUM AIRFLOW SETPOINTS TO MAINTAIN SPACE TEMPERATURE AT OCCUPIED COOLING SETPOINT.
 - FOR ZONES WITH OCCUPANCY SENSORS, ENTER "STANDBY MODE" IF THE OCCUPANCY SENSOR DOES NOT DETECT OCCUPANCY FOR 15 MINUTES (ADJ.). DURING STANDBY MODE, COOLING SETPOINT RESETS TO 3 DEGREES F (ADJ.) ABOVE NORMAL OCCUPIED COOLING SETPOINT AND HEATING SETPOINT RESETS TO 3 DEGREES F (ADJ.) BELOW NORMAL OCCUPIED HEATING SETPOINT. WHEN OCCUPANCY HAS BEEN DETECTED FOR 5 MINUTES (ADJ.), HEATING AND COOLING SETPOINTS RESET TO NORMAL OCCUPIED TEMPERATURE SETPOINTS.
 - IF SPACE CO2 CONCENTRATION IS GREATER THAN 800 PPM (ADJ.) MODULATE DAMPER BETWEEN MINIMUM AND MAXIMUM COOLING AIRFLOW SETPOINTS TO MAINTAIN CONCENTRATION AT SETPOINT.
- WARM-UP MODE: TERMINAL UNIT RECEIVES GLOBAL SIGNAL FROM BUILDING CONTROLLER TO INITIATE WARM-UP MODE. DURING WARM-UP MODE MODULATE DAMPER BETWEEN MINIMUM AND MAXIMUM AIRFLOW SETPOINTS TO MAINTAIN SPACE TEMPERATURE AT OCCUPIED HEATING SETPOINT.

2 VAV BOX CONTROL DIAGRAM

NO SCALE

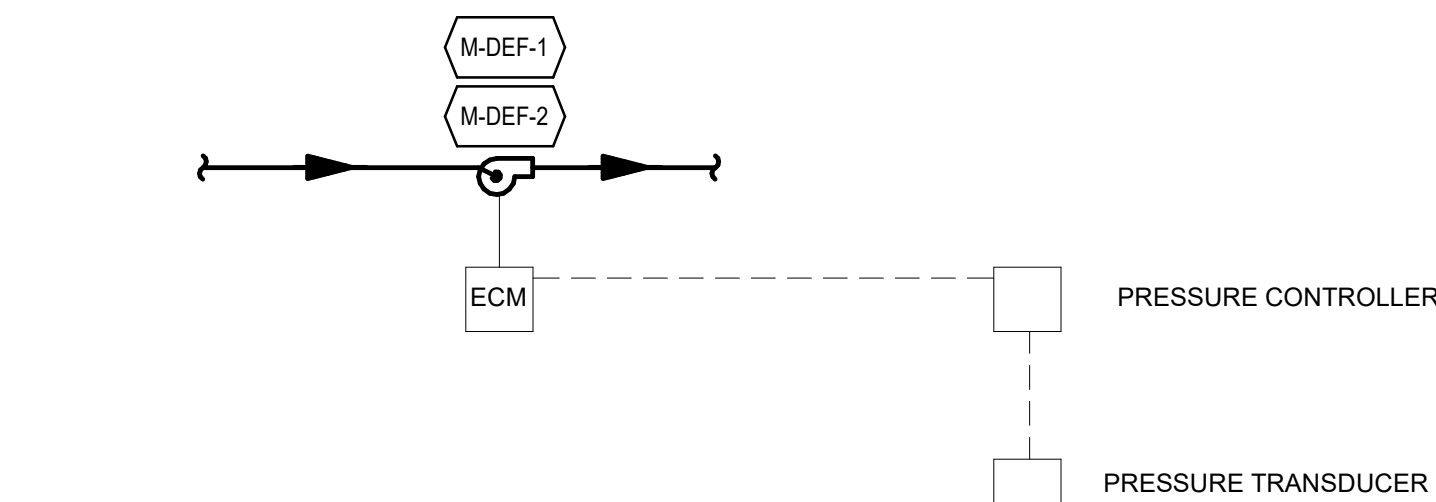

- SEQUENCE OF OPERATIONS**
- LAUNDRY EXHAUST FAN
THE LAUNDRY EXHAUST FAN IS TO BE CONTROLLED BY THE FAN MANUFACTURER'S MODULATING BUILDING EXHAUST SYSTEM CONTROLLER.

5 M-DEF-1 & M-DEF-2 CONTROL DIAGRAM

NO SCALE

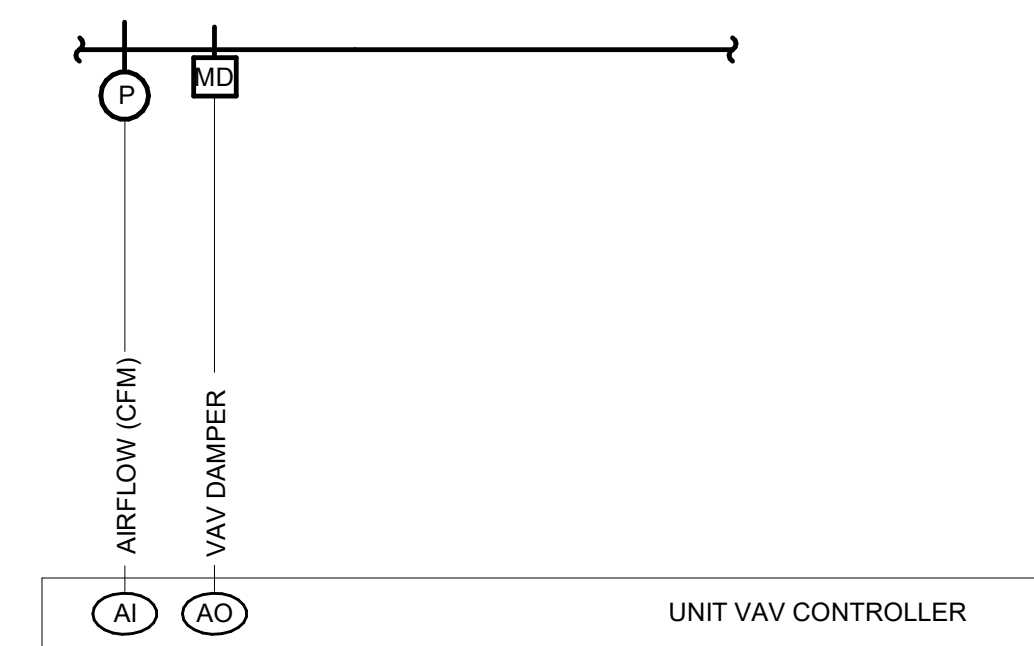

- TERMINAL UNIT CONTROLLER RECEIVES SIGNAL FROM BUILDING CONTROLLER WHICH INITIATES OCCUPIED OR UNOCCUPIED MODE. UNOCCUPIED MODE:
 - TERMINAL UNIT DAMPER CLOSED.
- OCCUPIED MODE
 - MODULATE DAMPER TO MAINTAIN AIRFLOW SETPOINT.

4 EVAV BOX CONTROL DIAGRAM

NO SCALE

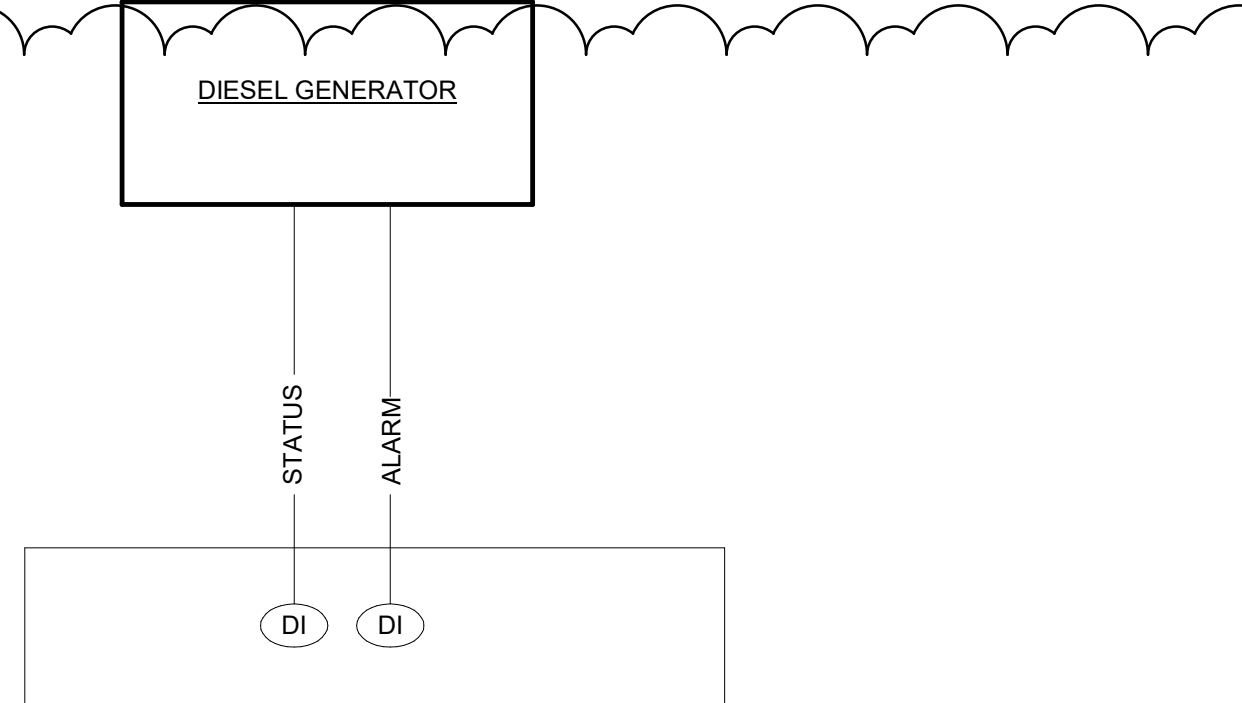

- MONITOR GENERATOR STATUS THROUGH INTEGRATION WITH THIRD PARTY GENERATOR CONTROL SYSTEM.
- MONITOR ALARM STATUS OF GENERATOR THROUGH INTEGRATION WITH THIRD PARTY CONTROL SYSTEM. GENERATE ALARM IF ALARMS ARE INDICATED, OR STATUS IS LOST FOR MORE THAN 1 MINUTE.

6 GENERATOR CONTROL DIAGRAM

NO SCALE

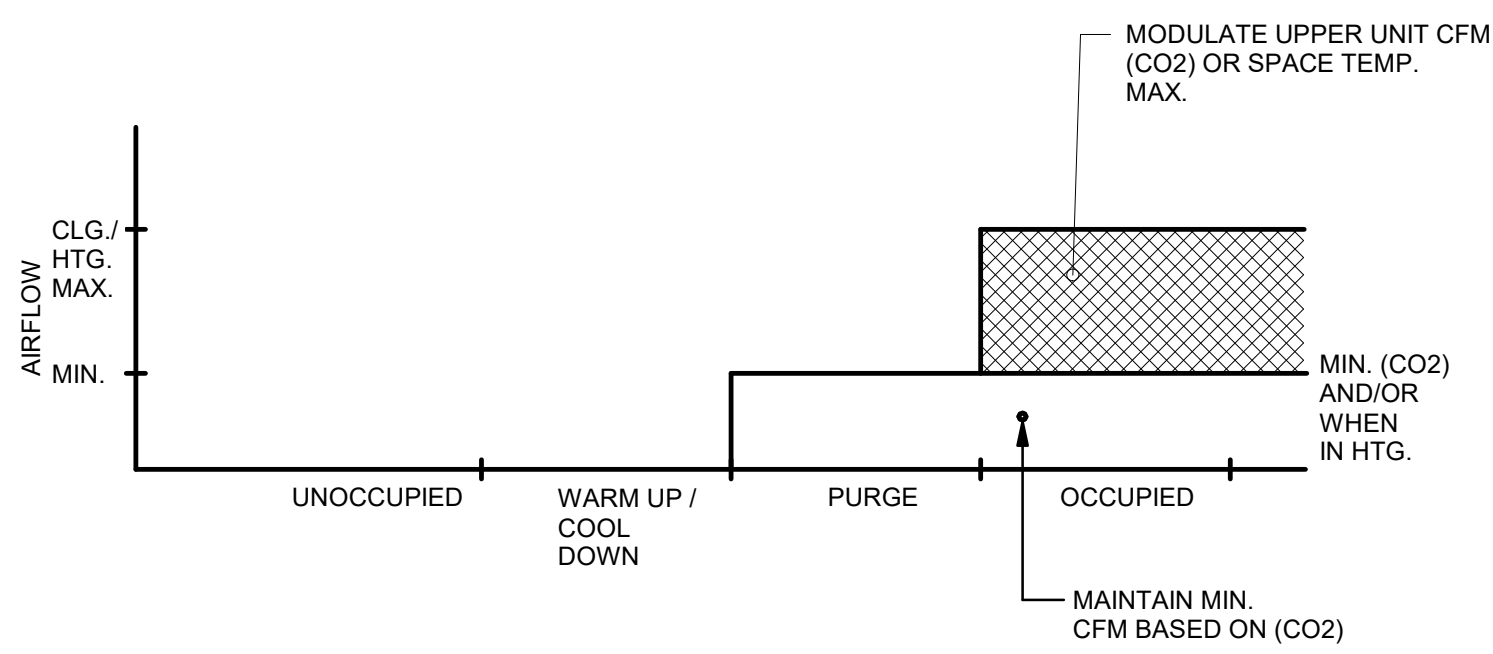
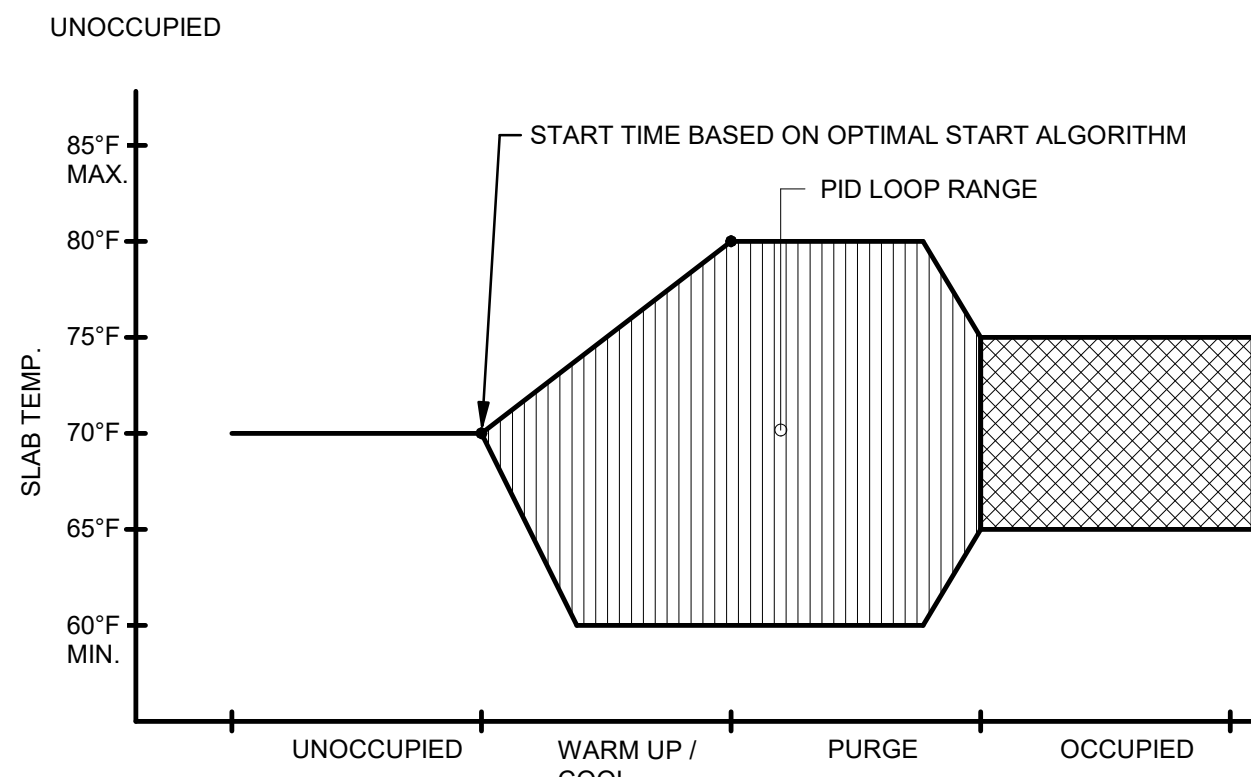

3 RADIANT SLAB CONTROL PARAMETERS

NO SCALE

TACTICAL TRAINING DESIGN

Tactical Design North, Inc.
231 E. Buffalo St #502, Milwaukee, WI 53202

LOCAL ARCHITECT

Jacobs Wyper Architects
1232 Chancellor St, Philadelphia, PA 19107

STRUCTURAL ENGINEER

Skidmore, Owings & Merrill LLP
250 Greenwich St, New York, NY 10007

ELECTRICAL, PLUMBING, FIRE PROTECTION, FIRE ALARM ENGINEER

A & J Consulting Engineering Services, P.C.
164 Brighton Rd, Clifton, NJ 07012

MECHANICAL, AVIATION ENGINEER

Interface Engineering, Inc.
2000 M Street NW, Suite 270, Washington, DC 20036

ACOUSTICAL ENGINEER

Cerami
1001 Ave of the Americas, 4th Floor, New York, NY 10018

CODE CONSULTANT

CCI
215 W 40th St, 10th Floor, New York, NY 10018

CIVIL ENGINEER

Langan
1818 Market St #3300, Philadelphia, PA 19103

VERTICAL TRANSPORT

Michael Blades & Associates Ltd.
5409 Rapiand Ct, Lothian, MD 20711

SIGNAGE CONSULTANT

Patricia Hord Graphik Design
119 S. St. Asaph St, Alexandria, VA 22314

LANDSCAPE

Lee and Associates, Inc.
6381 I Street NW, Washington, DC 20001

LIGHTING

MCCLA
1000 Potomac St NW, Suite 121, Washington, DC 20007

FOOD SERVICE

Hopkins Foodservice Specialists, Inc.
7906 MacArthur Blvd, Suite 100, Cabin John, MD 20818

POOL DESIGN

Aqua Design International
7536 N. La Cholla Blvd Tucson, AZ 85741

KEYPLAN

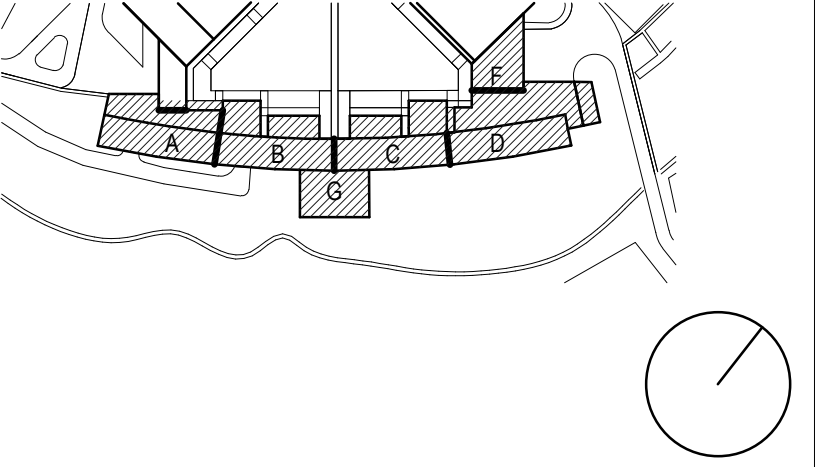

NO.	DATE	DESCRIPTION	NO.	DATE	DESCRIPTION
1	19 MAY 2023	ISSUED FOR BID			
2	29 JUN 2023	ADDENDUM 29			

RECORD REVISIONS

SIGNATURE _____ DATE _____

ARCHITECT
SOM
Skidmore, Owings & Merrill LLP
250 Greenwich St, New York, 10007

COMMONWEALTH OF PENNSYLVANIA
DEPARTMENT OF GENERAL SERVICES
HARRISBURG, PENNSYLVANIA

D.G.S. PROJECT No.
C-0211-0005 PHASE 6
Pennsylvania State Police Academy
Outbuildings, Tactical Villages & Sitework
PENNSYLVANIA STATE POLICE
HERSHEY, DAUPHIN COUNTY, PA

VERIFY SCALE

BAR IS ONE (1) INCH LONG
ON ORIGINAL DRAWING: 0 1
IF BAR IS NOT ONE (1) INCH LONG, ADJUST SCALE ACCORDINGLY

CONTRACTOR SHALL FIELD VERIFY ALL DIMENSIONS. VARIANCE FROM CONTRACT DOCUMENTS NOT PERMITTED WITHOUT PROFESSIONAL & BUREAU OF CONSTRUCTION APPROVAL.

SHEET No. **MAQ-M-807**

DRAWN BY Author	CHECKED BY Checker	DATE	SCALE AS NOTED
--------------------	-----------------------	------	-------------------

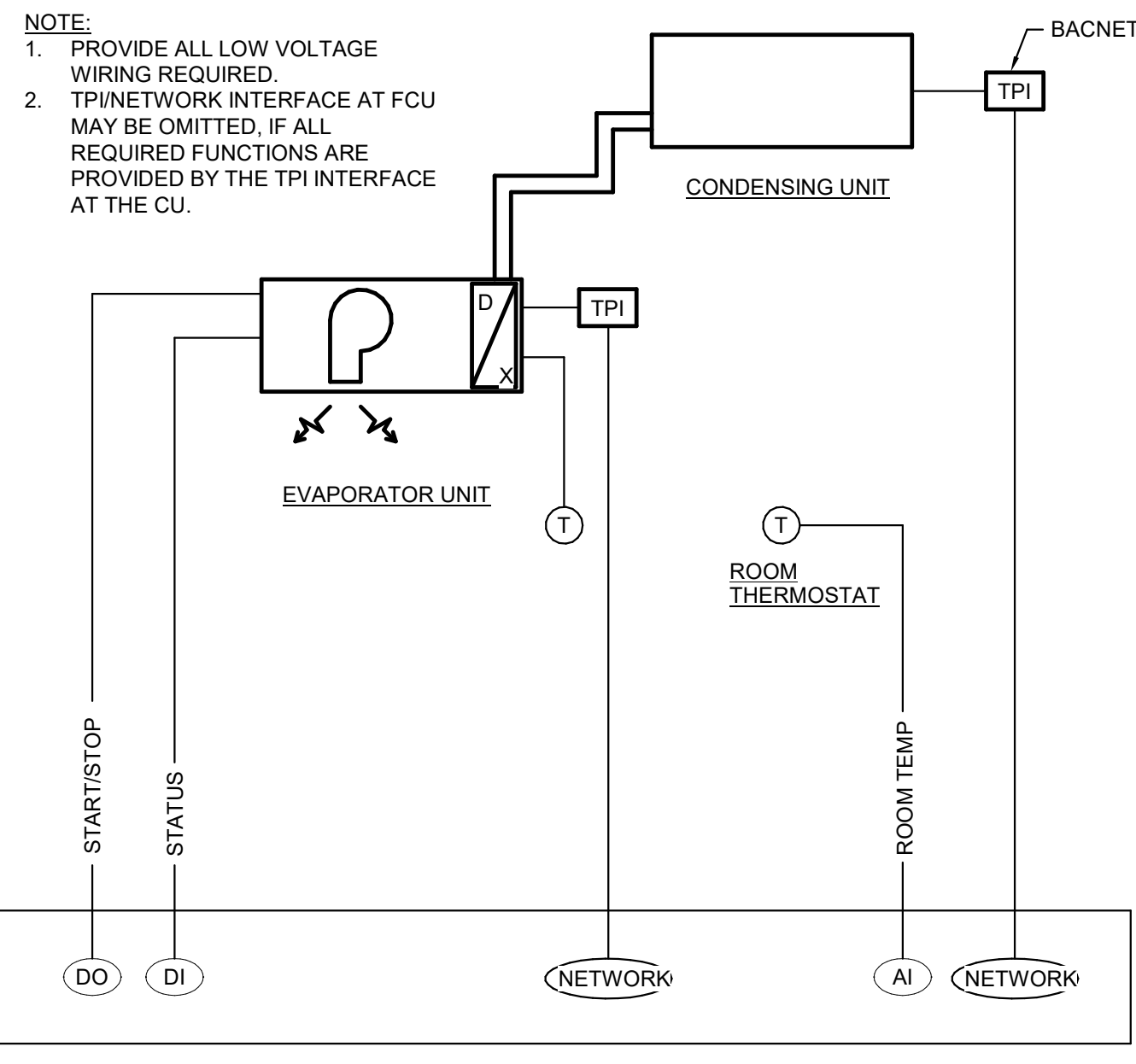

- GENERAL:**
- CONNECT TO THE UNIT'S CONTROLLER AND OPERATE UNIT AS INITIATED FROM BAS SCHEDULE.
 - EACH UNIT'S CONTROLLER WILL MONITOR AND CONTROL ITS FULL RANGE OF OPERATIONS. FAN RUNS CONTINUOUSLY, INCLUDING BOOSTER FANS, IF APPLICABLE. DETERMINE FAN SPEED TO DELIVER THE LOWEST AIR QUANTITY POSSIBLE BY THE SYSTEM TO MEET THE COOLING SETPOINT.
 - OPERATE FAN COIL UNITS AT THE FOLLOWING SETPOINT TEMPERATURES:
 - COOLING: 80°F (ADJ.)
 - GENERATE AN ALARM AT THE BAS WHEN THE SPACE TEMPERATURE EXCEEDS THE SETPOINT BY 4°.
 - CREATE A GRAPHICAL SCREEN FOR EACH VARIABLE REFRIGERANT FLOW SYSTEM, INCLUDING ALL CONNECTED FAN COILS AND CONDENSING UNITS, AND:
 - PROVIDE ABILITY OF INDIVIDUAL OR GLOBAL CHANGES TO:
 - TEMPERATURE SETPOINTS.
 - FAN SPEED.
 - FORCED SHUT DOWN OF COOLING (IE THE FAN CONTINUES OPERATION)
 - OPERATION MODE SETTING: COOL/FAN/DRY/AUTO.
 - FORCED SYSTEM STOP.
 - MONITOR THE FOLLOWING ADDITIONAL POINTS IN THE SYSTEM'S GRAPHICAL SCREEN:
 - UNIT ALARM.
 - MAJUNCTION CODE.
 - FILTER ALARM.
 - THERMO-ON STATUS (WHETHER THE UNIT IS ACTIVELY HEATING OR COOLING).
 - COMPRESSOR STATUS.
 - FAN STATUS.
 - COMMUNICATION STATUS.
 - REMOTE CONTROLLER PROHIBIT STATUS.

1 VRF & SPLIT SYSTEM CONTROL DIAGRAM

NO SCALE

4 MOTOR WITH VFD (TYPICAL)

NO SCALE

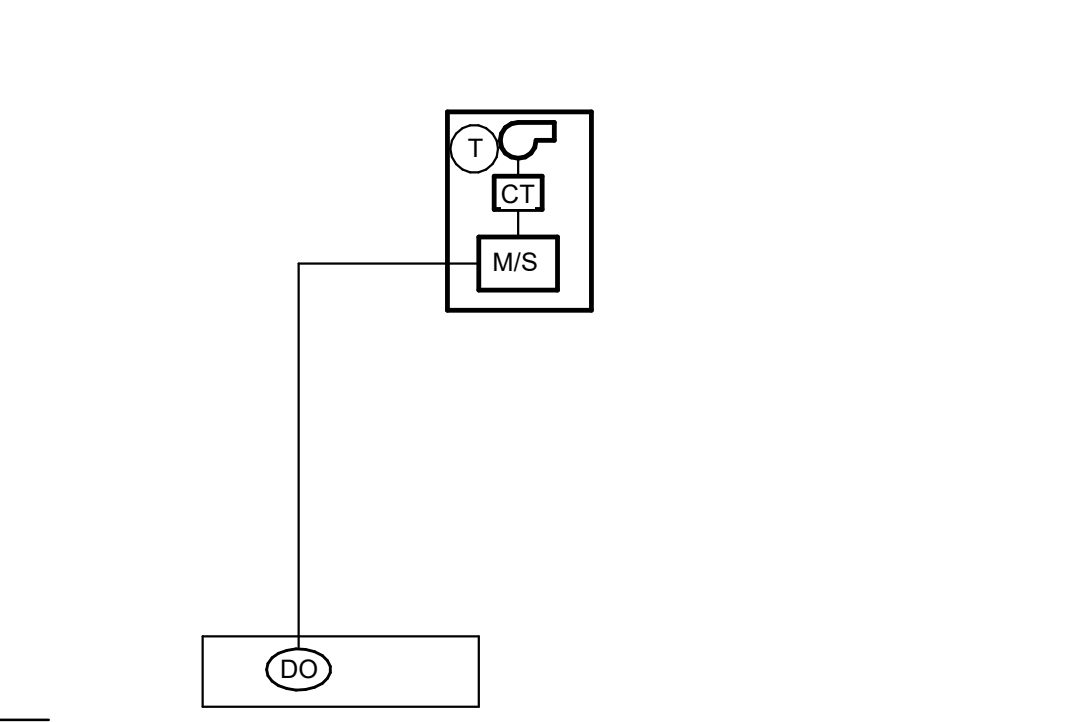

- PROVIDE BACNET COMPLIANT DIGITAL CONTROLLER.
- BUILDING AUTOMATION SYSTEM INTERFACE:
 - THE BUILDING AUTOMATION SYSTEM (BAS) SHALL SEND THE CONTROLLER COMMANDS.
- HEATING MODE:
 - THE BMS SHALL SEND A SIGNAL FOR UNIT TO RUN BASED ON OUTSIDE AIR TEMPERATURE.
 - THE UNIT SHALL RUN TO MAINTAIN AN INTERNALLY SET TEMPERATURE SETPOINT.

2 MOTOR W/ STARTER (TYPICAL)

NO SCALE

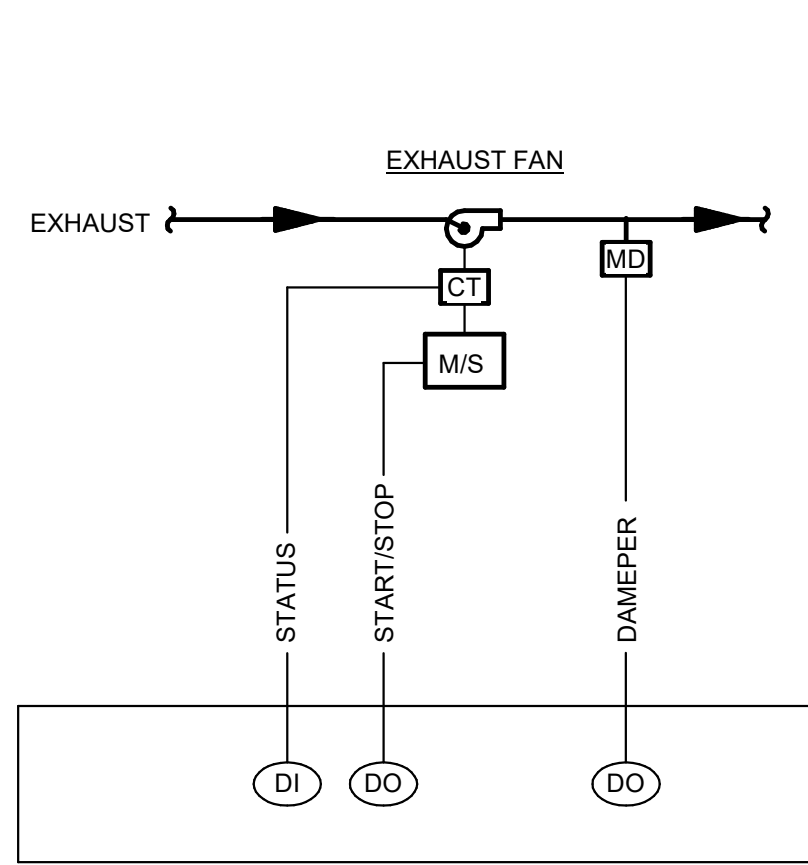

- FAN TO START/STOP BASED ON OCCUPANCY SCHEDULE.
- DAMPER TO OPEN DURING OCCUPIED MODES AND CLOSE DURING UNOCCUPIED MODES.
- GENERATE AN ALARM IF STATUS IS LOST FOR MORE THAN 1 MINUTE, MOTOR FAULT, MOTOR FAILURE, IS OFF, OR IN HAND.

3 EXHAUST FAN CONTROL (TYPICAL)

NO SCALE



5 UNIT HEATER CONTROL DIAGRAM

NO SCALE

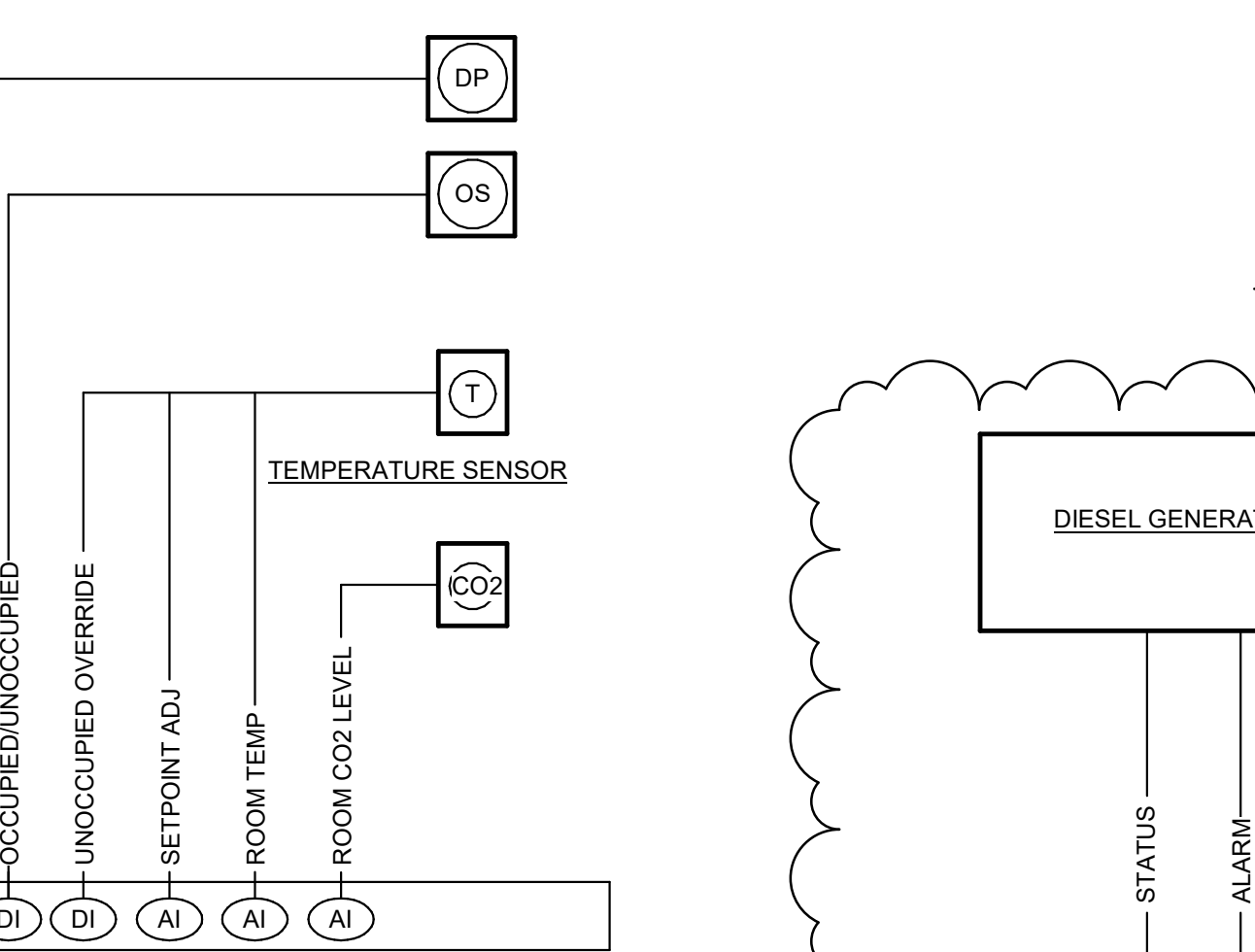

- NOTE:**
- PROVIDE DIGITAL DISPLAY EXCEPT WHERE LOCATED IN LOBBIES AND CORRIDORS.
 - PROVIDE CO2 SENSORS AS SHOWN ON DRAWINGS AND IN ROOMS WITH A MIN OCCUPANCY OF 40 PERSONS PER 1,000 SF.
 - USE OCCUPANCY SENSORS FROM LIGHTING CONTROL SYSTEM FOR OCCUPANCY CONTROL WHEN AVAILABLE.
 - PROVIDE DEWPOINT SENSOR IN SPACES SERVED BY RADIANT OR SENSIBLE COOLING EQUIPMENT.

6 ROOM THERMOSTAT (TYPICAL)

NO SCALE

7 FAN COIL UNIT CONTROL DIAGRAM (COOLING ONLY)

NO SCALE

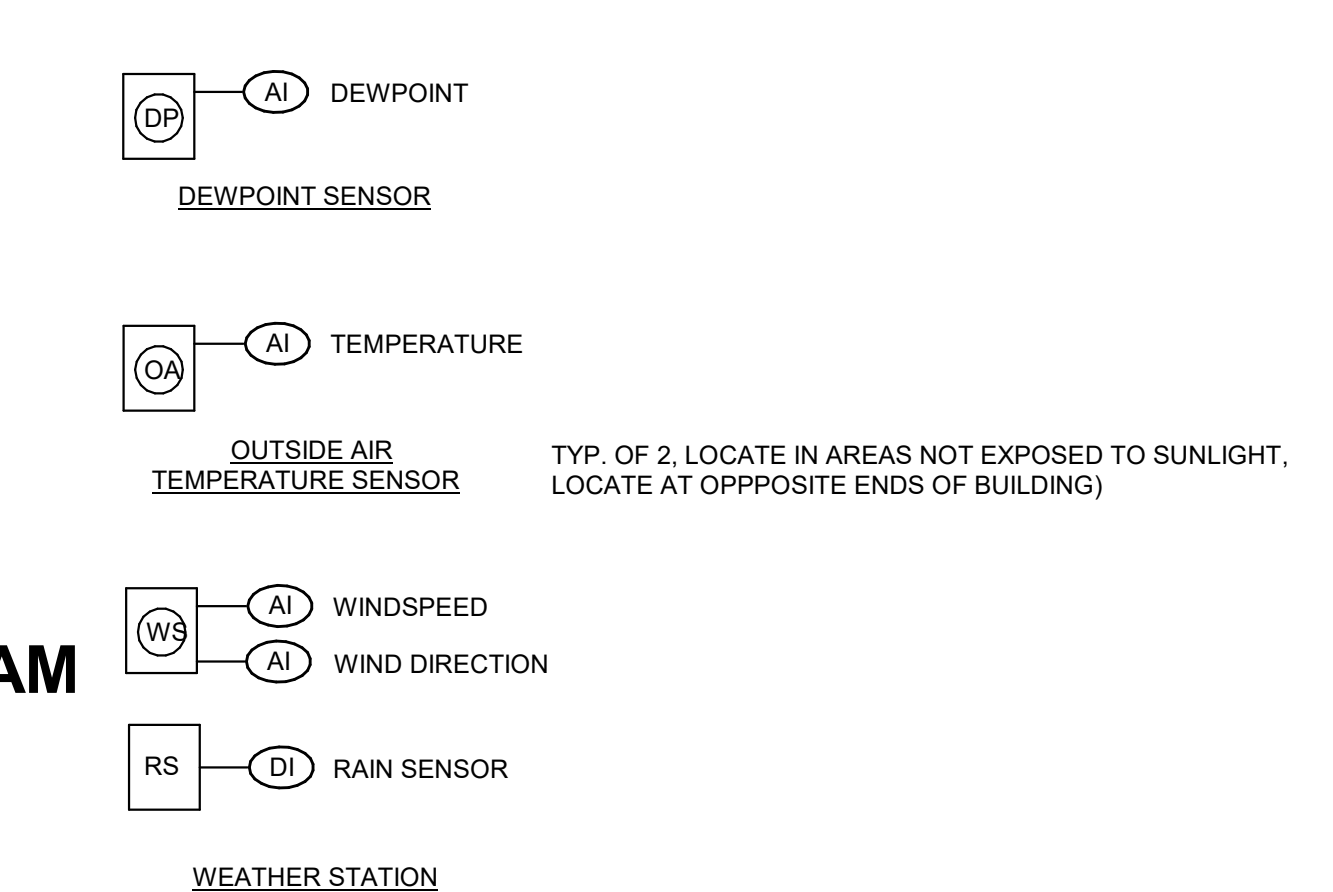

8 MISCELLANEOUS POINTS

NO SCALE

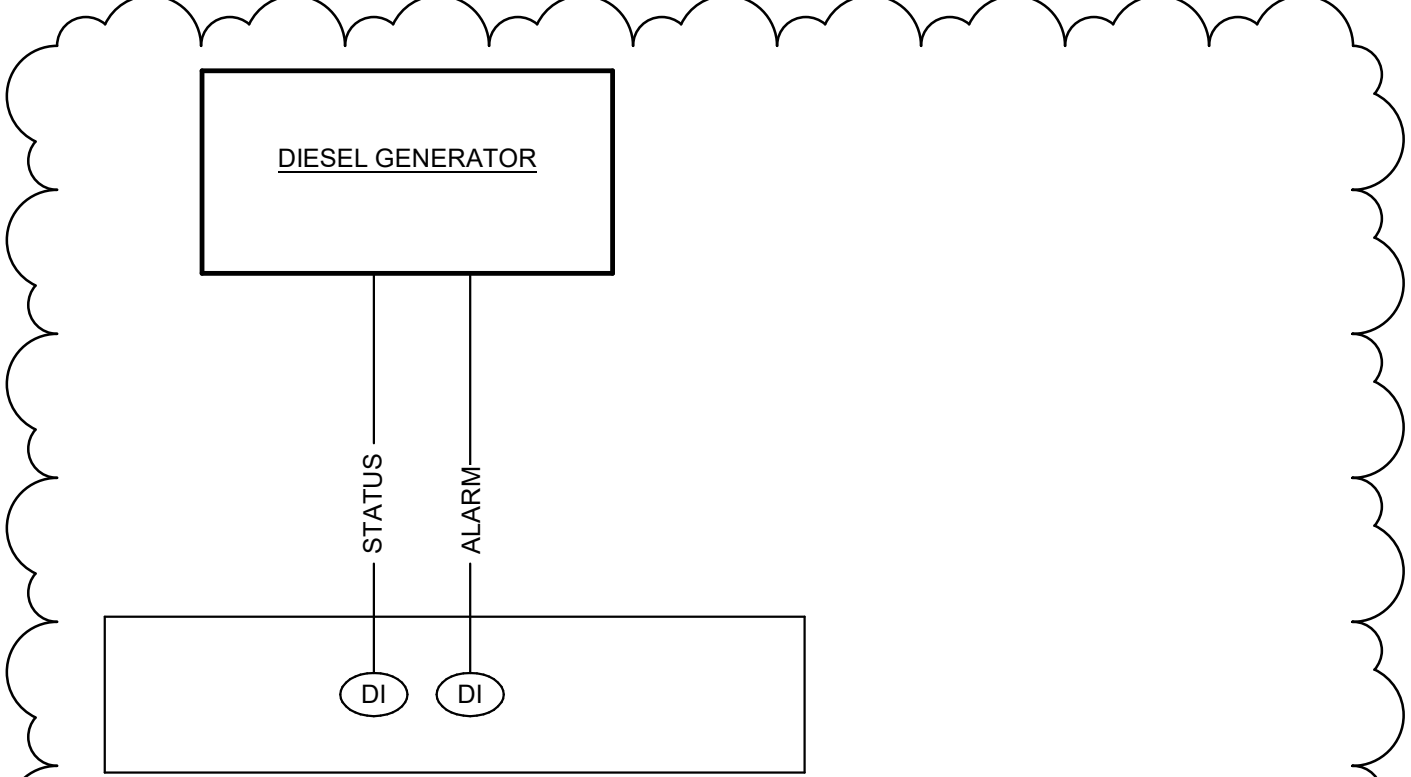

- MONITOR GENERATOR STATUS THROUGH INTEGRATION WITH THIRD PARTY GENERATOR CONTROL SYSTEM.
- MONITOR ALARM STATUS OF GENERATOR THROUGH INTEGRATION WITH THIRD PARTY CONTROL SYSTEM. GENERATE ALARM IF ALARMS ARE INDICATED, OR STATUS IS LOST FOR MORE THAN 1 MINUTE.

12 GENERATOR CONTROL DIAGRAM

NO SCALE

9 VAV BOX CONTROL DIAGRAM (WITH ELECTRIC REHEAT)

NO SCALE

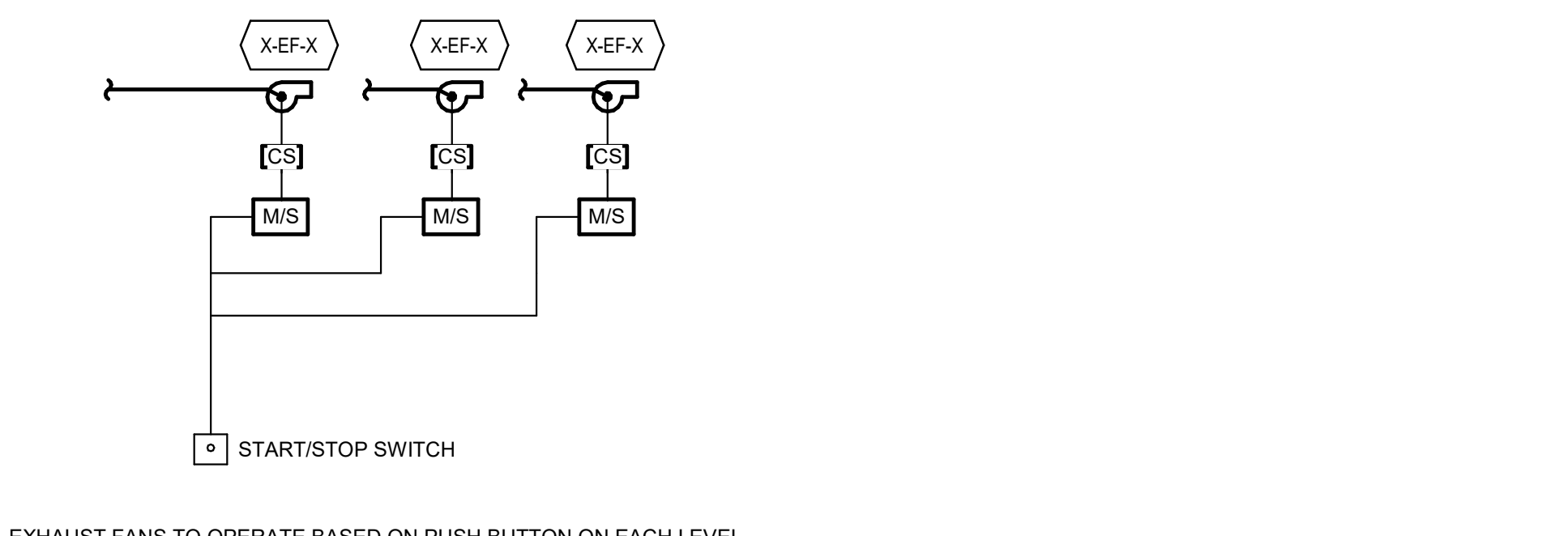

- EXHAUST FANS TO OPERATE BASED ON PUSH BUTTON ON EACH LEVEL.

10 OTV/COV EXHAUST FANS CONTROL DIAGRAM

NO SCALE

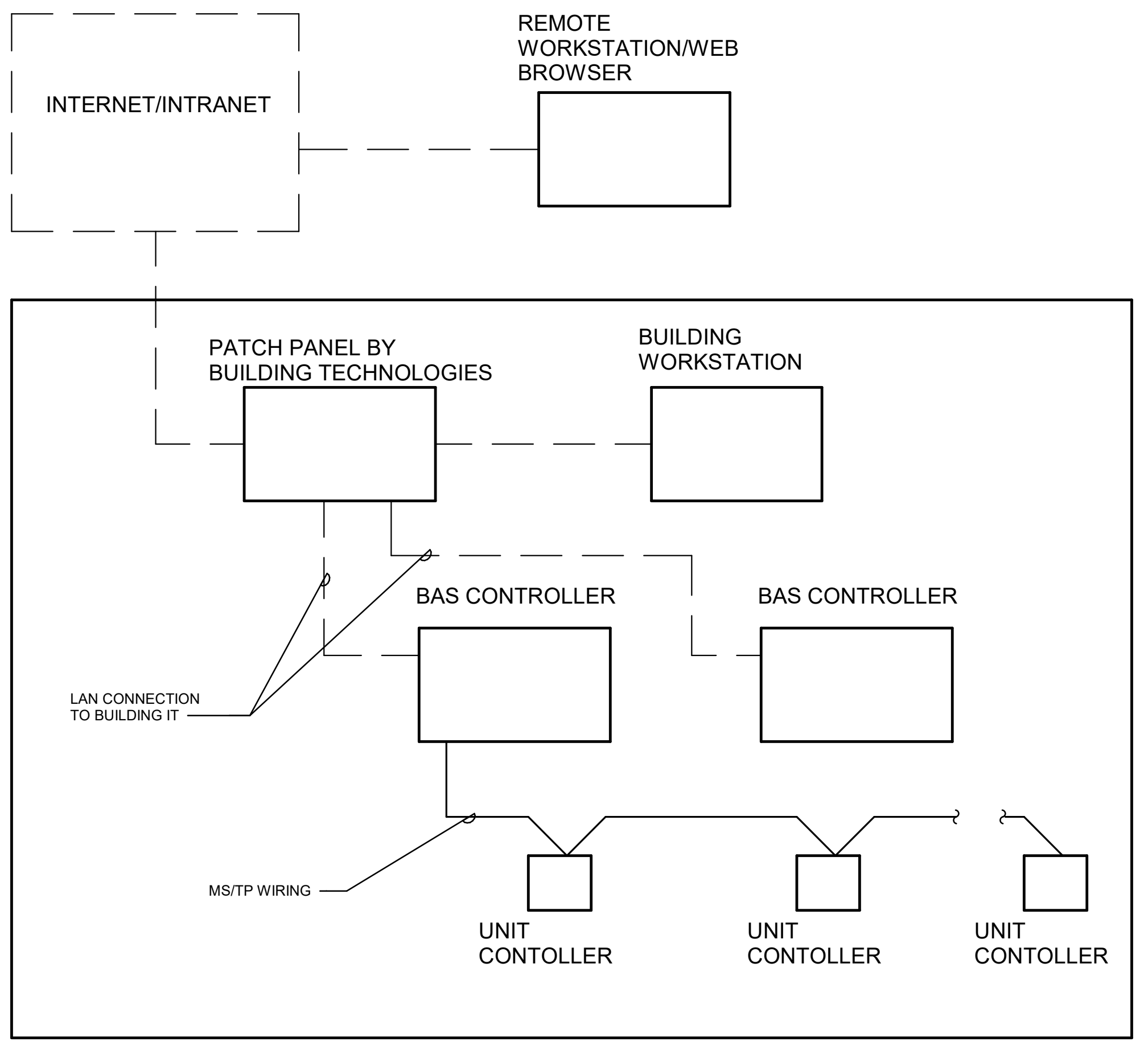

11 BAS ARCHITECTURE

NO SCALE

TACTICAL TRAINING DESIGN

Tactical Design North
 231 E. Buffalo St #502, Milwaukee, WI 53202

LOCAL ARCHITECT

Jacobs Wyper Architects
 1232 Chancellor St, Philadelphia, PA 19107

STRUCTURAL ENGINEER

Skidmore, Owings & Merrill LLP
 250 Greenwich St, New York, NY 10007

ELECTRICAL, PLUMBING, FIRE PROTECTION, FIRE ALARM ENGINEER

A & J Consulting Engineering Services, P.C.
 164 Brighton Rd, Clifton, NJ 07012

MECHANICAL AVIATION ENGINEER

Interface Engineering, Inc.
 2000 M Street NW, Suite 270, Washington, DC 20036

ACOUSTICAL ENGINEER

Cerami
 1001 Ave of the Americas, 4th Floor, New York, NY 10018

CODE CONSULTING

CCI
 215 W 40th St, 10th Floor, New York, NY 10018

CIVIL ENGINEER

Langan
 1818 Market St #3300, Philadelphia, PA 19103

VERTICAL TRANSPORT

Michael Blades & Associates Ltd.
 5409 Rapihan Ct, Lothian, MD 20711

SIGNAGE CONSULTANT

Patricia Hord Graphik Design
 119 S. St. Asaph St, Alexandria, VA 22314

LANDSCAPE

Lee and Associates, Inc.
 638 I Street NW, Washington, DC 20001

LIGHTING

MCLA
 1000 Patomac St NW, Suite 121, Washington, DC 20007

FOOD SERVICE

Hopkins Foodservice Specialists, Inc.
 7906 MacArthur Blvd, Suite 100, Cabin John, MD 20818

COST ESTIMATING

AECOM
 1700 Market St, Suite 1600, Philadelphia, PA 19103

KEYPLAN

NO.	DATE	DESCRIPTION	NO.	DATE	DESCRIPTION
3	16 JUN 2023	ISSUED FOR BID			

RECORD REVISIONS	
NO.	DESCRIPTION

ARCHITECT

SOM
 Skidmore, Owings & Merrill LLP
 250 Greenwich St, New York, 10007

COMMONWEALTH OF PENNSYLVANIA
 DEPARTMENT OF GENERAL SERVICES
 HARRISBURG, PENNSYLVANIA

D.G.S. PROJECT No.

C-0211-0005 PHASE 6

PA State Police Academy
 Outbuildings, Tactical Villages & Sitework
 PENNSYLVANIA STATE POLICE
 HERSHEY, DAUPHIN COUNTY, PA

VERIFY SCALE			
BAR IS ONE (1) INCH LONG	ON ORIGINAL DRAWING:	0	1
IF BAR IS NOT ONE (1) INCH LONG, ADJUST SCALE ACCORDINGLY			
SHEET No.			
OTV-M-800			
DRAWN BY	CHECKED BY	DATE	SCALE
Author	Checker		AS NOTED

TAG	USE	MATERIALS	DIMENSION/ THICKNESS	FINISH / COLOR	JOINT	SETTING BED	MANUFACTURER/ MODEL	PATTERN	NOTES
LBCH-01	AMPHITHEATER BENCH	METAL	SEE PLAN	DARK GREY	N/A	N/A	VESTRE		SLATTED PERFORATED METAL TOP
		METAL WITH IPE BENCH TOP					MMCITE		
LBCH-02	AUDITORIUM ROOF BENCH	CAST STONE	SEE PLAN	POLISHED/BLACK			LANDSCAPE FORMS/SOCRATES BENCH		
BO-01	BOLLARD	BOLLARD		STAINLESS STEEL			AMERISTAR BULWARK SECURITY BOLLARD	N/A	SEE ALSO CIVIL DETAILS
LCP	PIP CONCRETE PAVING	3' X 3' SCORED PIP CONCRETE	SEE CIVIL DRAWINGS FOR THICKNESS	LIGHT BROOM FINISH	SAWCUT SEE PLANS	N/A	N/A	SEE PLAN	SEE ALSO CIVIL DETAILS
LDG	DECOMPOSED GRANITE	DECOMPOSED GRANITE	N/A	SUBMIT ALL COLOR SAMPLES OF COLOR GOLD VARIETY	N/A	N/A	N/A	N/A	
LME-01	METAL EDGE	ALUMINUM	5.5"X6.5" GEOEDGE WITH BASE IN CORNER	BLACK DURAFLEX	N/A	N/A	PERMALOC	N/A	
PAV-01	CONCRETE PAVERS AT GRADE	SERIES CONCRETE PAVERS	7 7/8" X 7 7/8" X 2 3/4"	MOUNTAIN MIST CHARCOAL CHARCOAL	MORTAR	MORTAR	JNIOLOCK/SERIES PAVER NITTERHOUSE/INTERLOCKING PAVER	SEE PLAN	PAV-01 ALT 1 PAV-01 ALT 2
PAV-02	CONCRETE PAVERS AT GRADE	PLANK PAVER	8" X 24" X 2.75"	OPAL PG-2 NATURAL	MORTAR	MORTAR	JNIOLOCK / PROMENADE PLANK PAVER NITTERHOUSE/URBAN STONE HANOVER/PLANKSTONE PAVERS	SEE PLAN	PAV-02 ALT 1 PAV-02 ALT 2
PAV-03	CONCRETE PAVERS	PLANK PAVER	8" X 24" X 2.75"	STEEL GREY BLEND	SEE NOTES	SEE NOTES	JNIOLOCK / PROMENADE PLANK PAVER	SEE PLAN	PAVERS ON GRADE TO BE OVER CONCRETE BASE PER 3/STE-L-900 PAVERS OVER MARQUEE BUILDING LEVEL 0 TO BE ON AGGREGATE BASE PER 8/STE-L-900 PAVERS OVER MARQUEE AUDITORIUM ROOF TO BE ON PEDESTALS PER 6/STE-L-900
PAV-04	CONCRETE PAVERS AT GRADE	PLANK PAVER	4" X 12" X 2.75"	PG-60 LIMESTONE GRAY BLACK GRANITE	MORTAR	MORTAR	JNIOLOCK / PROMENADE PLANK PAVER NITTERHOUSE/URBAN STONE HANOVER/PLANKSTONE PAVERS	SEE PLAN	PAV-03 ALT 1 PAV-03 ALT 2 PAV-04 ALT 1 PAV-04 ALT 2
LST-01	RIVER ROCK	RIVER ROCK	3"-5" DIA. DISC SHAPE	NATURAL	N/A	N/A	EARDEROCK STONE/DELAWARE RIVER STONE	N/A	PROVIDE 6" CONTINUOUS STRIP BETWEEN ALL PLANTING BEDS AND BUILDING EDGES
TE-01	TRASH ENCLOSURE	CHAIN LINK FENCE	6' HEIGHT						SEE SPECIFICATION 323113

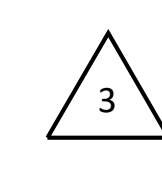
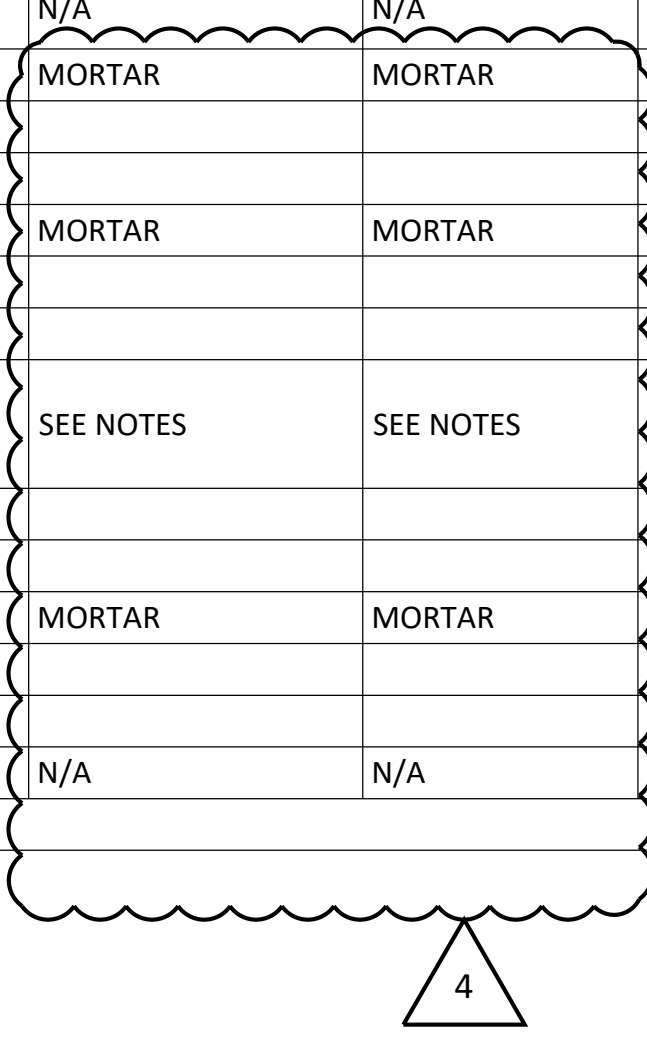

1 MATERIALS SCHEDULE

- TACTICAL TRAINING DESIGN
- Tactical Design North, Inc.**
231 E. Buffalo St #502, Milwaukee, WI 53202
- LOCAL ARCHITECT
- Jacobs Wyper Architects**
1232 Chancellor St, Philadelphia, PA 19107
- STRUCTURAL ENGINEER
- Skidmore, Owings & Merrill LLP**
250 Greenwich St, New York, NY 10007
- ELECTRICAL, PLUMBING, FIRE PROTECTION, FIRE ALARM ENGINEER
- A & J Consulting Engineering Services, P.C.**
164 Brighton Rd, Clifton, NJ 07012
- MECHANICAL, AVIT ENGINEER
- Interface Engineering, Inc.**
2000 M Street NW, Suite 270, Washington, DC 20036
- ACOUSTICAL ENGINEER
- Cerami**
1001 Ave of the Americas, 4th Floor, New York, NY 10018
- CODE CONSULTING
- CCI**
215 W 40th St, 10th Floor, New York, NY 10018
- CIVIL ENGINEER
- Langan**
1818 Market St #3300, Philadelphia, PA 19103
- VERTICAL TRANSPORT
- Michael Blades & Associates Ltd.**
5409 Rapidan Ct, Lothian, MD 20711
- SIGNAGE CONSULTANT
- Patricia Hord Graphik Design**
119 S. St. Asaph St, Alexandria, VA 22314
- LANDSCAPE
- Lee and Associates, Inc.**
638 I Street NW, Washington, DC 20001
- LIGHTING
- MCLA**
1000 Patomic St NW, Suite 121, Washington, DC 20007
- FOOD SERVICE
- Hopkins Foodservice Specialists, Inc.**
7906 MacArthur Blvd, Suite 100, Cabin John, MD 20818
- POOL DESIGN
- AQUA Design International**
7536 N. La Cholla Blvd, Tucson, AZ 85741

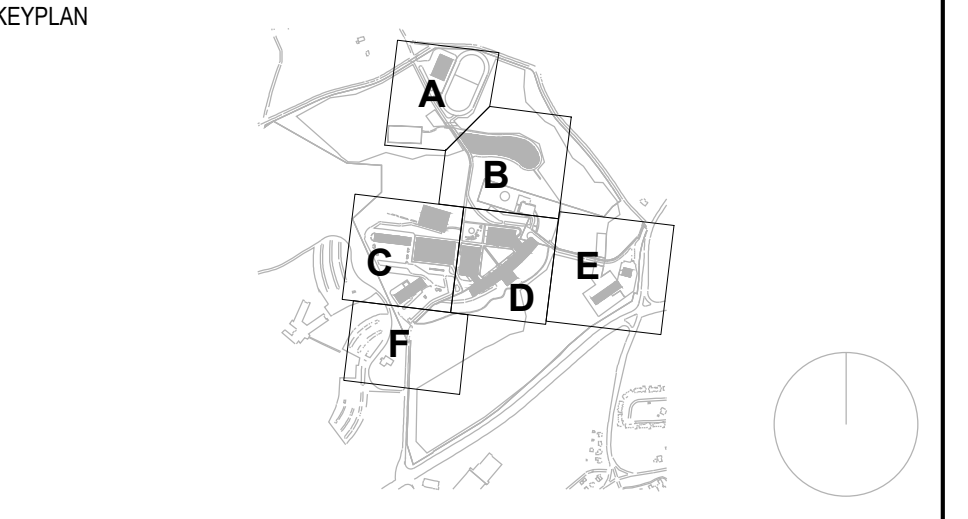

NO.	DATE	DESCRIPTION	NO.	DATE	DESCRIPTION
4	30 JUN 2023	ADDENDUM 29			
3	16 JUN 2023	ADDENDUM 27			
2	19 MAY 2023	ISSUED FOR BID			
1	18 FEB 2023	ISSUED TO L&M			

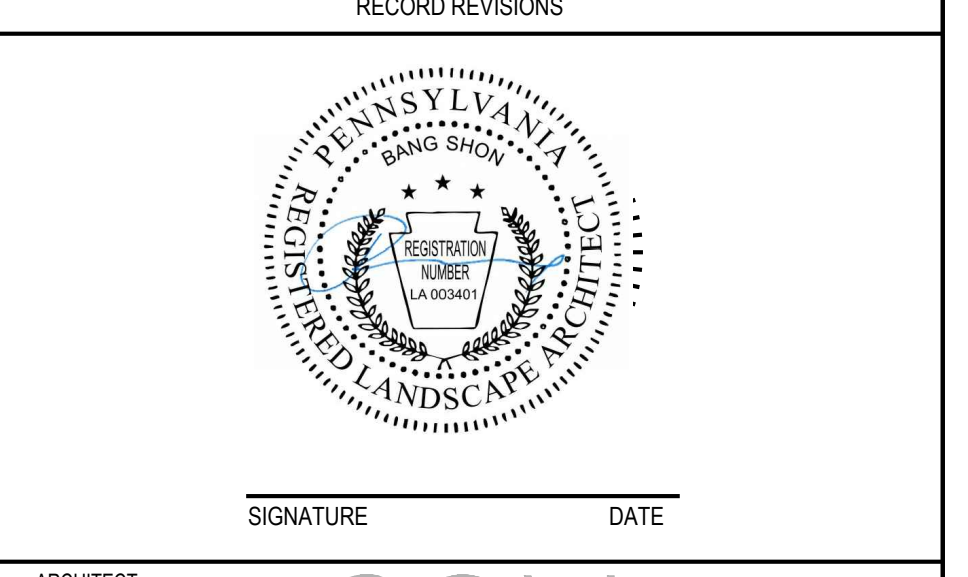

ARCHITECT

SOM
Skidmore, Owings & Merrill LLP
250 Greenwich St, New York, 10007

COMMONWEALTH OF PENNSYLVANIA
DEPARTMENT OF GENERAL SERVICES
HARRISBURG, PENNSYLVANIA

D.G.S. PROJECT No. **C-0211-0005 PHASE 5**

Pennsylvania State Police Academy
Core Buildings, BESO & Sitewory
PENNSYLVANIA STATE POLICE
HERSHEY, DAUPHIN COUNTY, PA

VERIFY SCALE			
BAR IS ONE (1) INCH LONG ON ORIGINAL DRAWING: 0 1			
IF BAR IS NOT ONE (1) INCH LONG, ADJUST SCALE ACCORDINGLY			
CONTRACTOR SHALL FIELD VERIFY ALL DIMENSIONS. VARIANCE FROM CONTRACT DOCUMENTS NOT PERMITTED WITHOUT PROFESSIONAL & BUREAU OF CONSTRUCTION APPROVAL.			
SHEET No. STE-L-110		SCALE AS NOTED	
DRAWN BY LB/DJ	CHECKED BY BS	DATE MAY 2023	PAGE NUMBER

NOTE:
1. SCORING PATTERN SHALL BE 3'-0" O.C. BOTH DIRECTIONS UNLESS OTHERWISE NOTED ON PLAN.

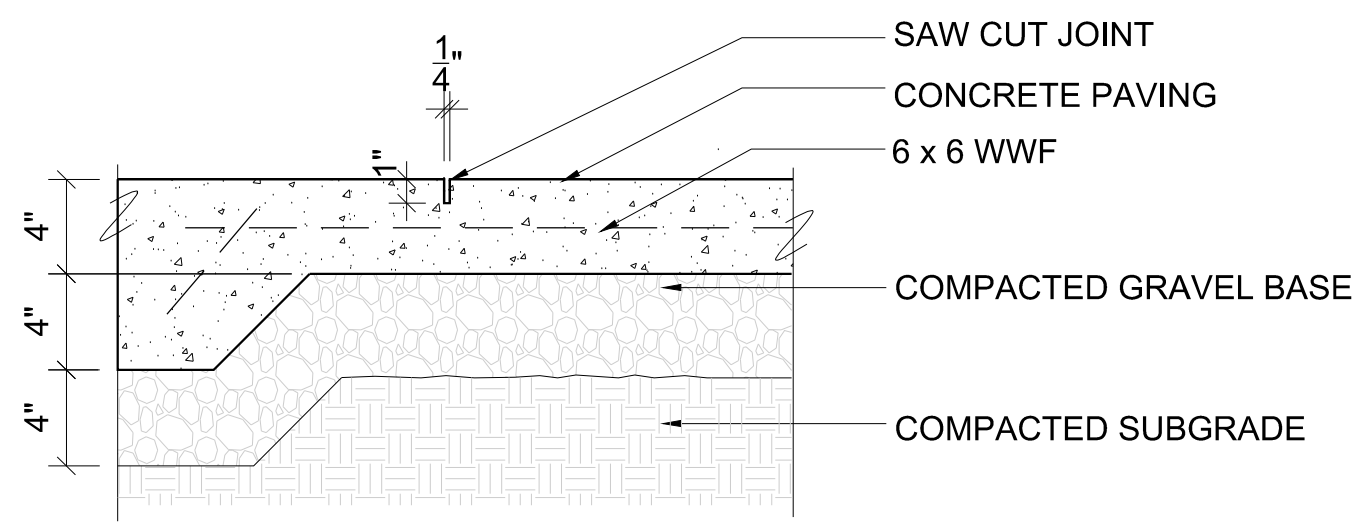

1 CAST-IN-PLACE CONCRETE PAVING (LCP)
SCALE: 1-1/2" = 1'-0"

NOTE:
EXPANSION JOINTS OCCUR AT ALL FIXED OBJECTS, CURBS, AND WALLS.
EXPANSION JOINTS SHALL OCCUR AT +/-21'-24" O.C. AT CORING PATTERN INTERVAL.

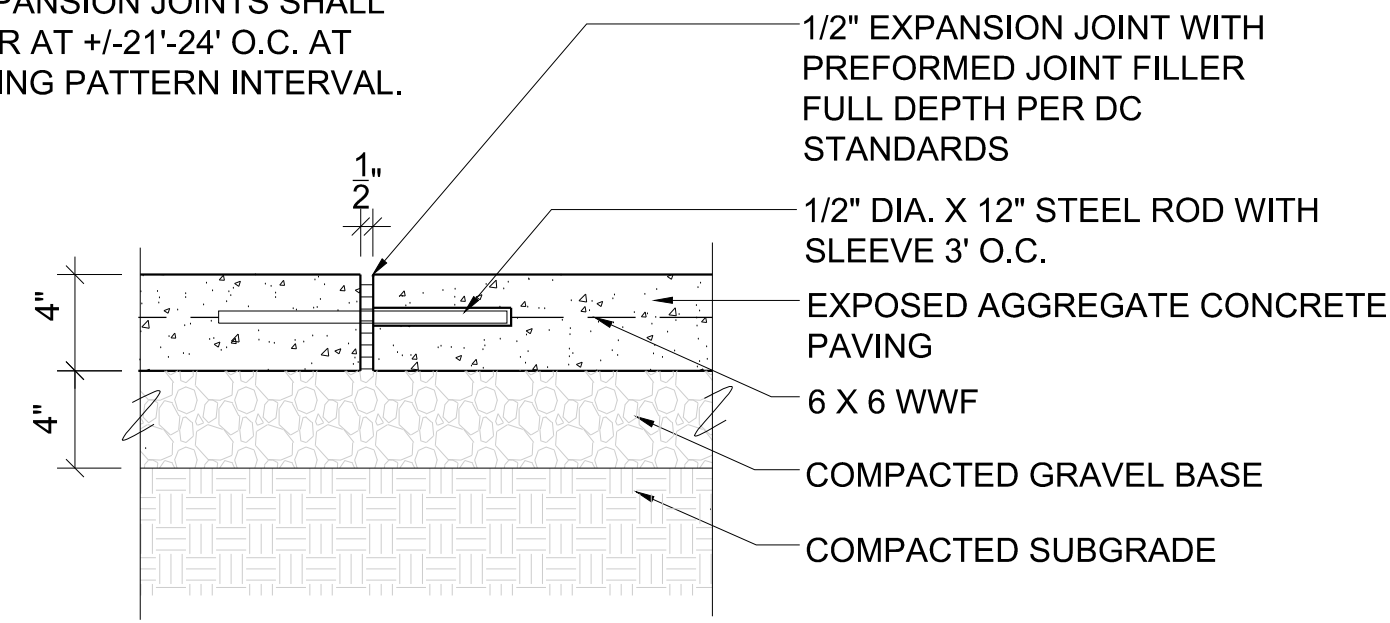

2 CAST-IN-PLACE CONCRETE PAVING - EXPANSION JOINT
SCALE: 1-1/2" = 1'-0"

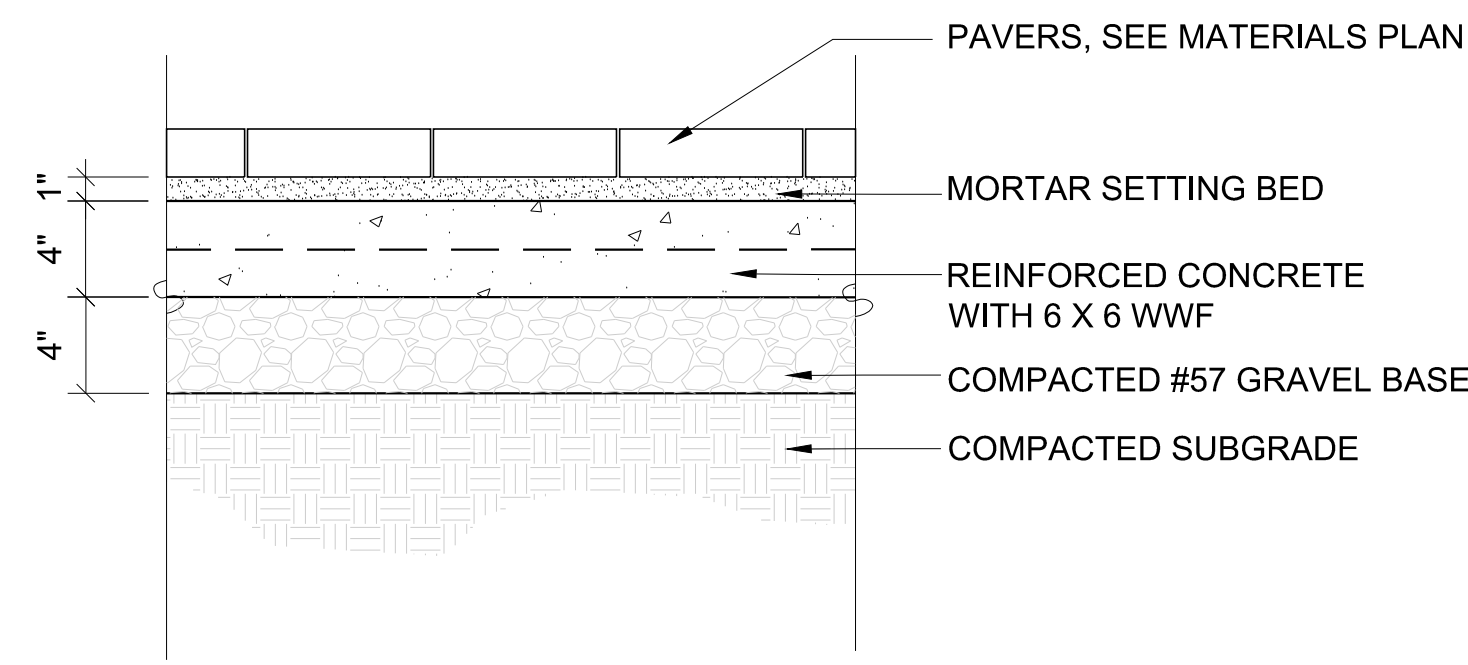

3 PAVERS AT GRADE ON CONCRETE BASE
SCALE: 1-1/2" = 1'-0"

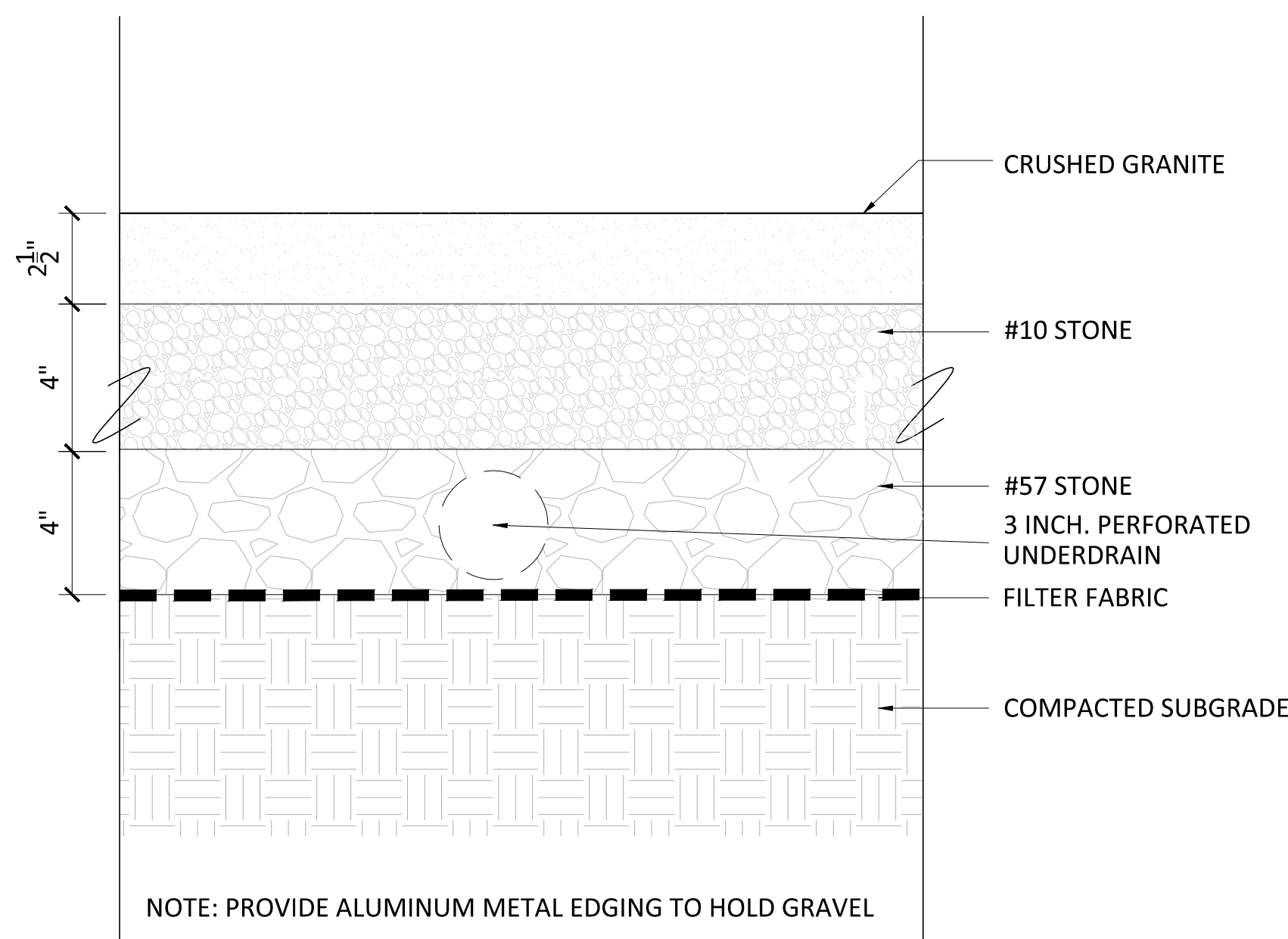

4 DECOMPOSED GRANITE PAVING (LDG)
SCALE: 3" = 1'-0"

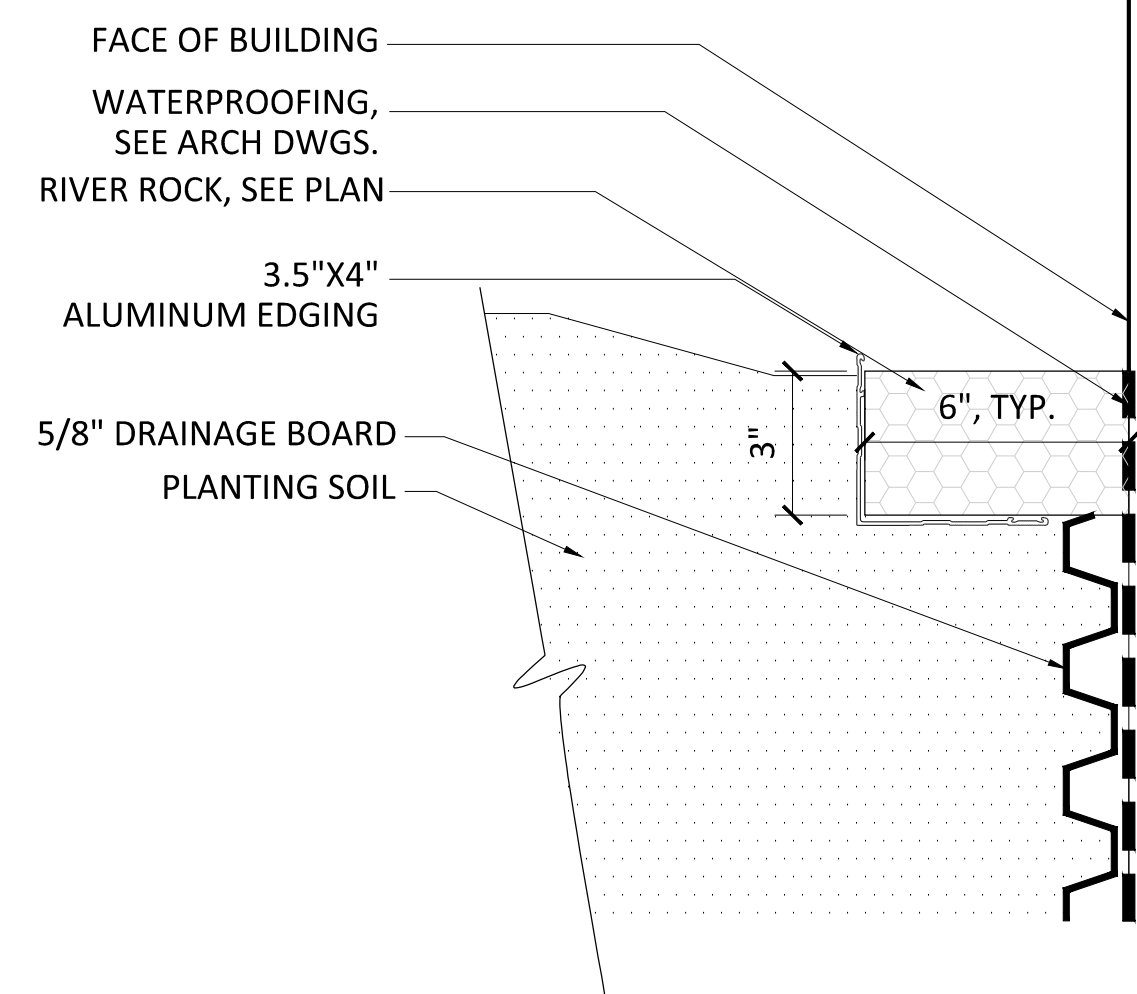

5 RIVER ROCK AT BUILDING EDGE (LST-01)
SCALE: 3" = 1'-0"

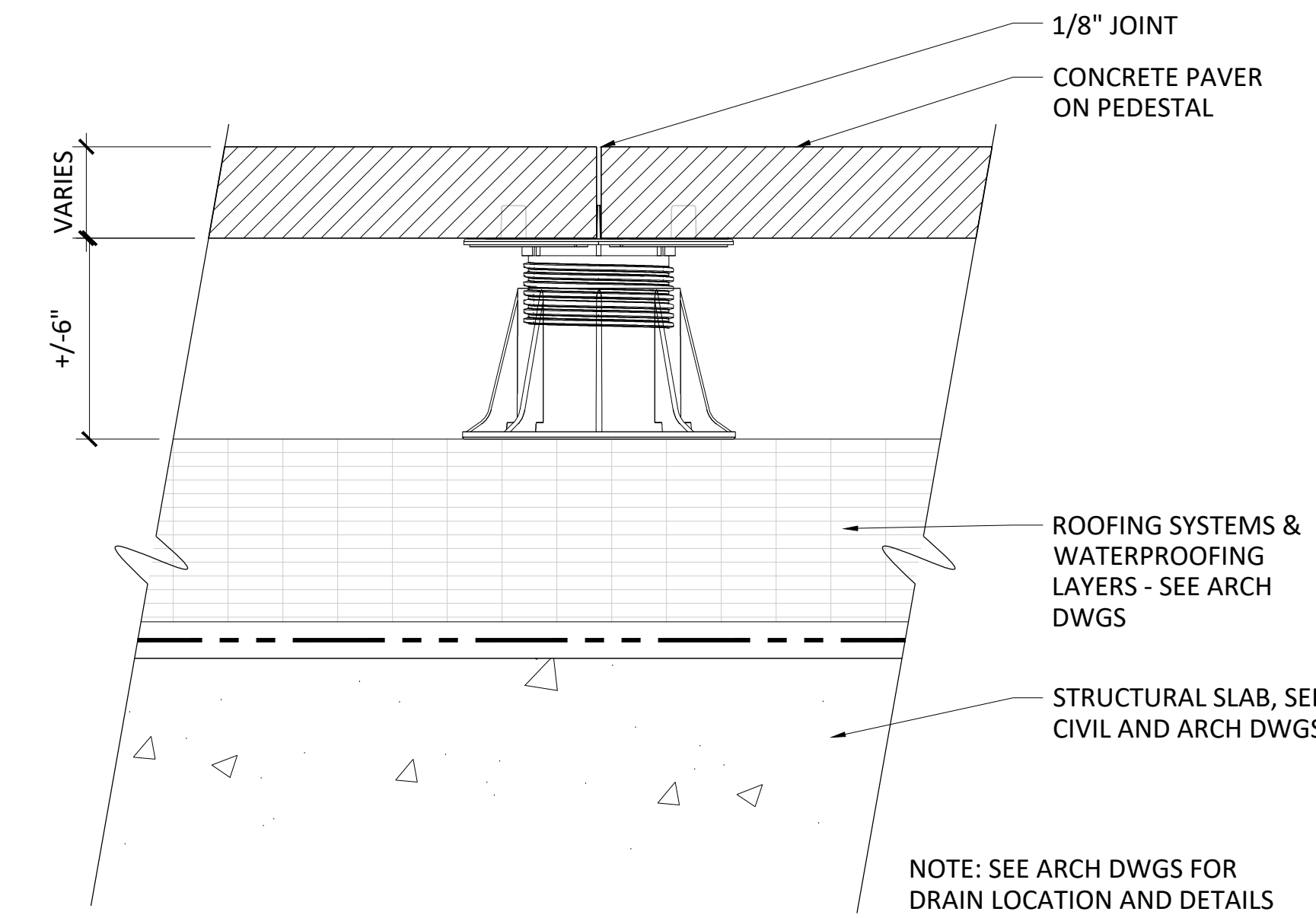

6 PAV-03 ON PEDESTALS

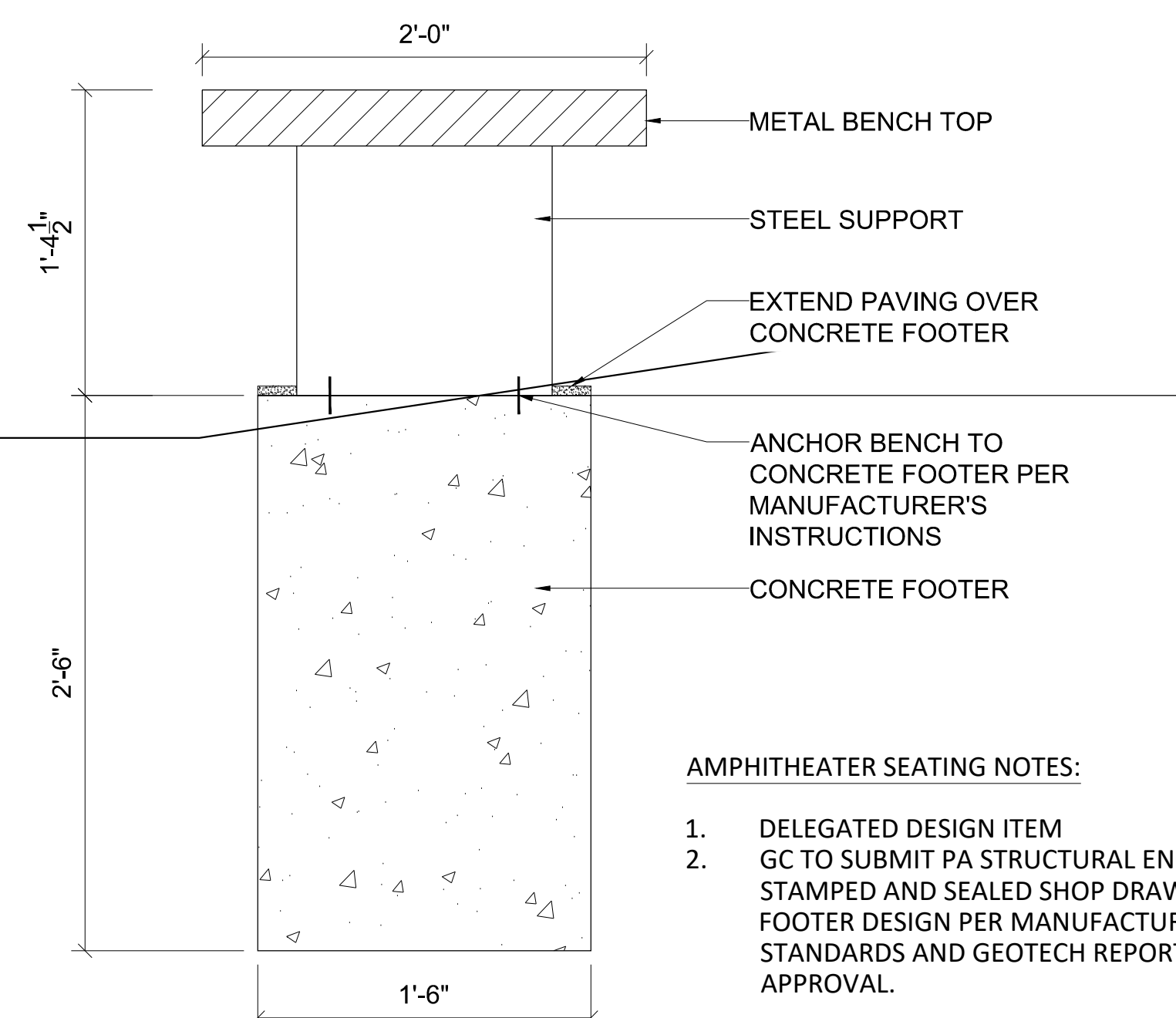

7 AMPHITHEATER SEATING (LBCH-01)
SCALE: 1 1/2" = 1'-0"

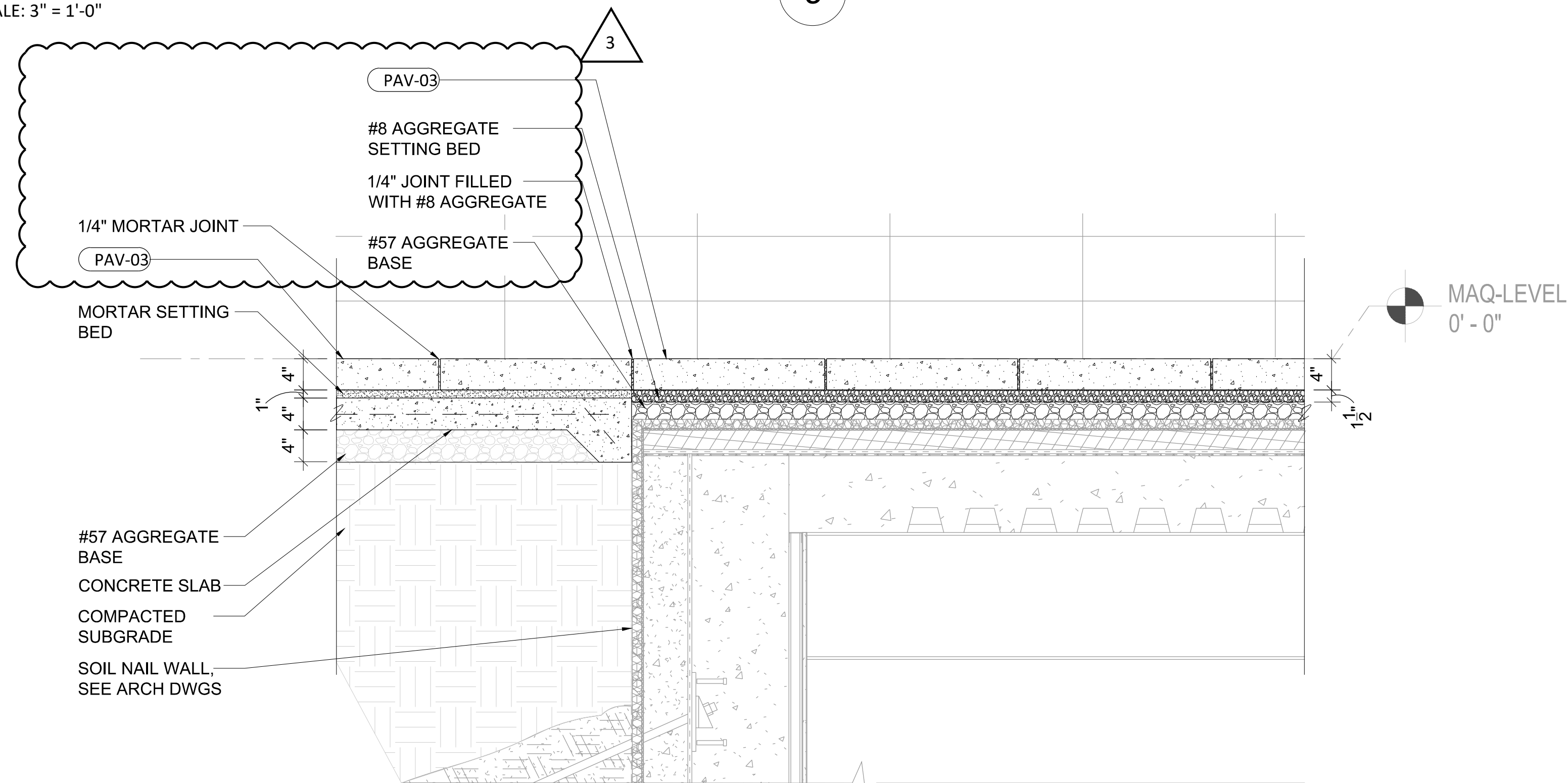

8 ON STRUCTURE TO ON GRADE PAVER TRANSITION
SCALE: 1 1/2" = 1'-0"

TACTICAL TRAINING DESIGN
Tactical Design North, Inc.
231 E. Buffalo St #502, Milwaukee, WI 53202

LOCAL ARCHITECT
Jacobs Wyper Architects
1232 Chancellor St, Philadelphia, PA 19107

STRUCTURAL ENGINEER
Skidmore, Owings & Merrill LLP
250 Greenwich St, New York, NY 10007

ELECTRICAL, PLUMBING, FIRE PROTECTION, FIRE ALARM ENGINEER
A & J Consulting Engineering Services, P.C.
164 Brighton Rd, Clifton, NJ 07012

MECHANICAL, AVIATION ENGINEER
Interface Engineering, Inc.
2000 M Street NW, Suite 270, Washington, DC 20036

ACOUSTICAL ENGINEER
Cerami
1001 Ave of the Americas, 4th Floor, New York, NY 10018

CODE CONSULTING
CCI
215 W 40th St, 10th Floor, New York, NY 10018

CIVIL ENGINEER
Langan
1818 Market St #3300, Philadelphia, PA 19103

VERTICAL TRANSPORT
Michael Blades & Associates Ltd.
5409 Rapidan Ct, Lothian, MD 20711

SIGNAGE CONSULTANT
Patricia Hord Graphik Design
119 S. St. Asaph St, Alexandria, VA 22314

LANDSCAPE
Lee and Associates, Inc.
638 I Street NW, Washington, DC 20001

LIGHTING
MCLA
1000 Patomic St NW, Suite 121, Washington, DC 20007

FOOD SERVICE
Hopkins Foodservice Specialists, Inc.
7906 MacArthur Blvd, Suite 100, Cabin John, MD 20818

POOL DESIGN
AQUA Design International
7536 N. La Cholla Blvd, Tucson, AZ 85741

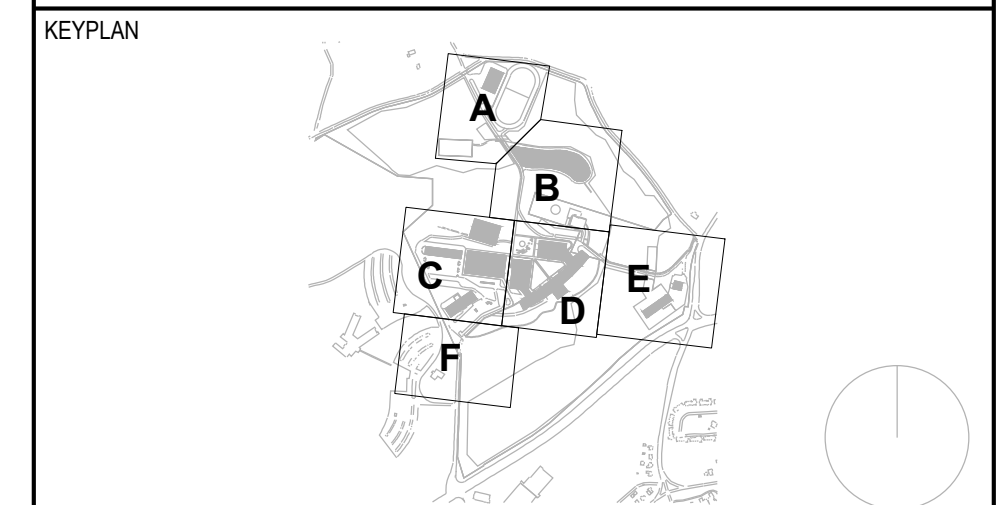

NO.	DATE	DESCRIPTION	NO.	DATE	DESCRIPTION
3	30 JUN 2023	ADDENDUM 29			
2	19 MAY 2023	ISSUED FOR BID			
1	18 FEB 2022	ISSUED TO L&I			

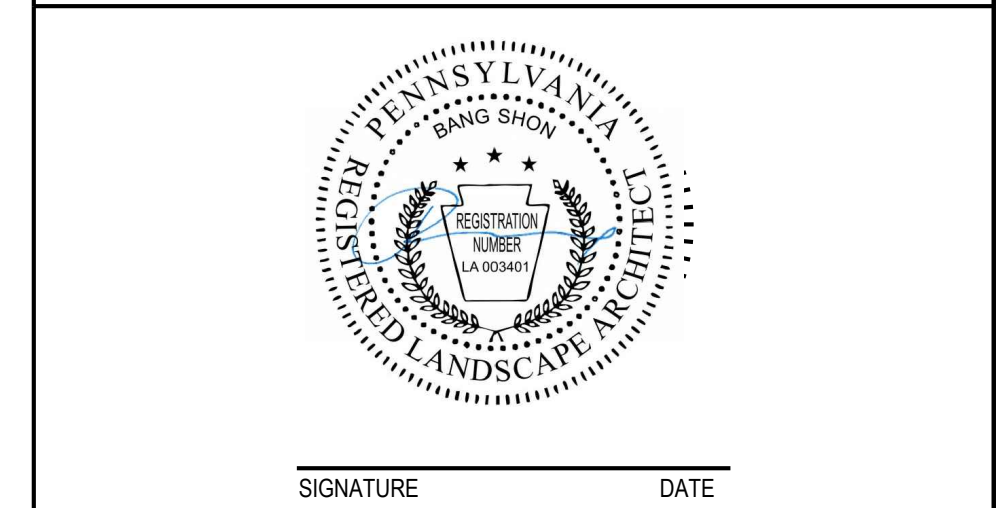

ARCHITECT
Skidmore, Owings & Merrill LLP
250 Greenwich St, New York, 10007

COMMONWEALTH OF PENNSYLVANIA
DEPARTMENT OF GENERAL SERVICES
HARRISBURG, PENNSYLVANIA

D.G.S. PROJECT No. **C-0211-0005 PHASE 5**
Pennsylvania State Police Academy
Core Buildings, BESO & Sitework
PENNSYLVANIA STATE POLICE
HERSHEY, DAUPHIN COUNTY, PA

VERIFY SCALE

BAR IS ONE (1) INCH LONG ON ORIGINAL DRAWING: 0 1
IF BAR IS NOT ONE (1) INCH LONG, ADJUST SCALE ACCORDINGLY

CONTRACTOR SHALL FIELD VERIFY ALL DIMENSIONS VARIANCE FROM CONTRACT DOCUMENTS NOT PERMITTED WITHOUT PROFESSIONAL & BUREAU OF CONSTRUCTION APPROVAL.

SHEET No. STE-L-900			
DRAWN BY LB/DJ	CHECKED BY BS	DATE MAY 2023	SCALE AS NOTED

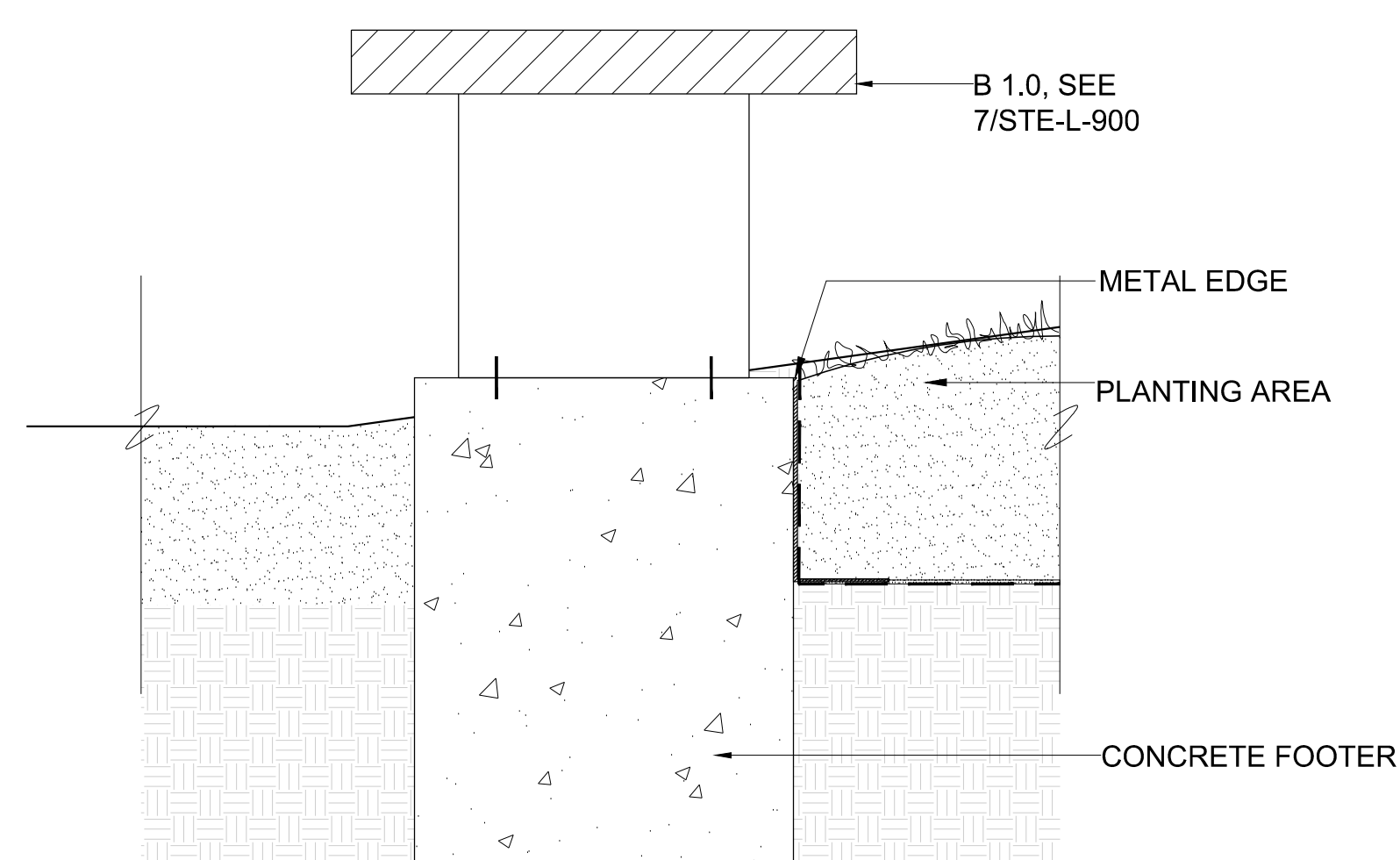

1 METAL EDGING
SCALE: 1-1/2" = 1'-0"

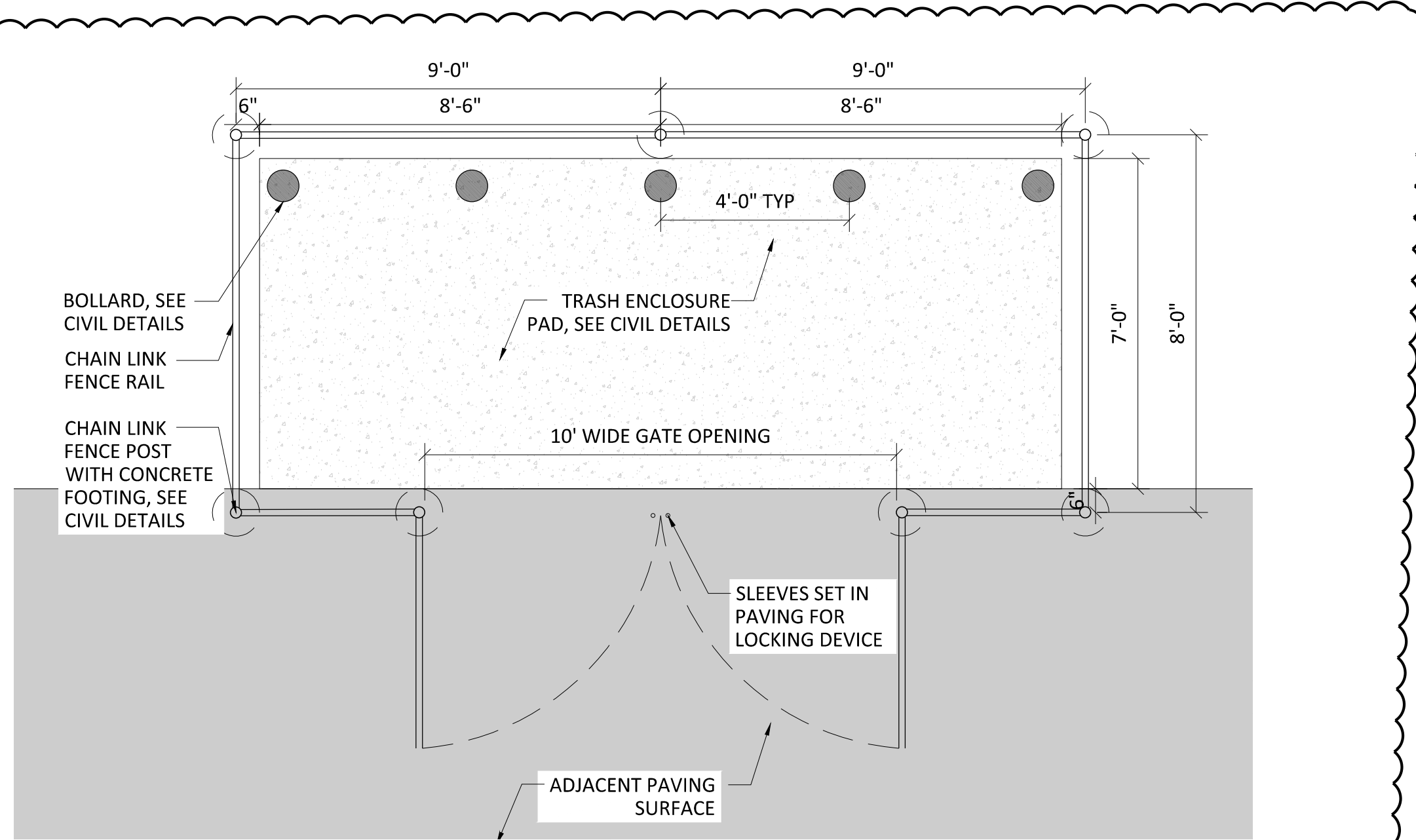

3 TE-01 ENLARGED PLAN
3/8" = 1'-0"

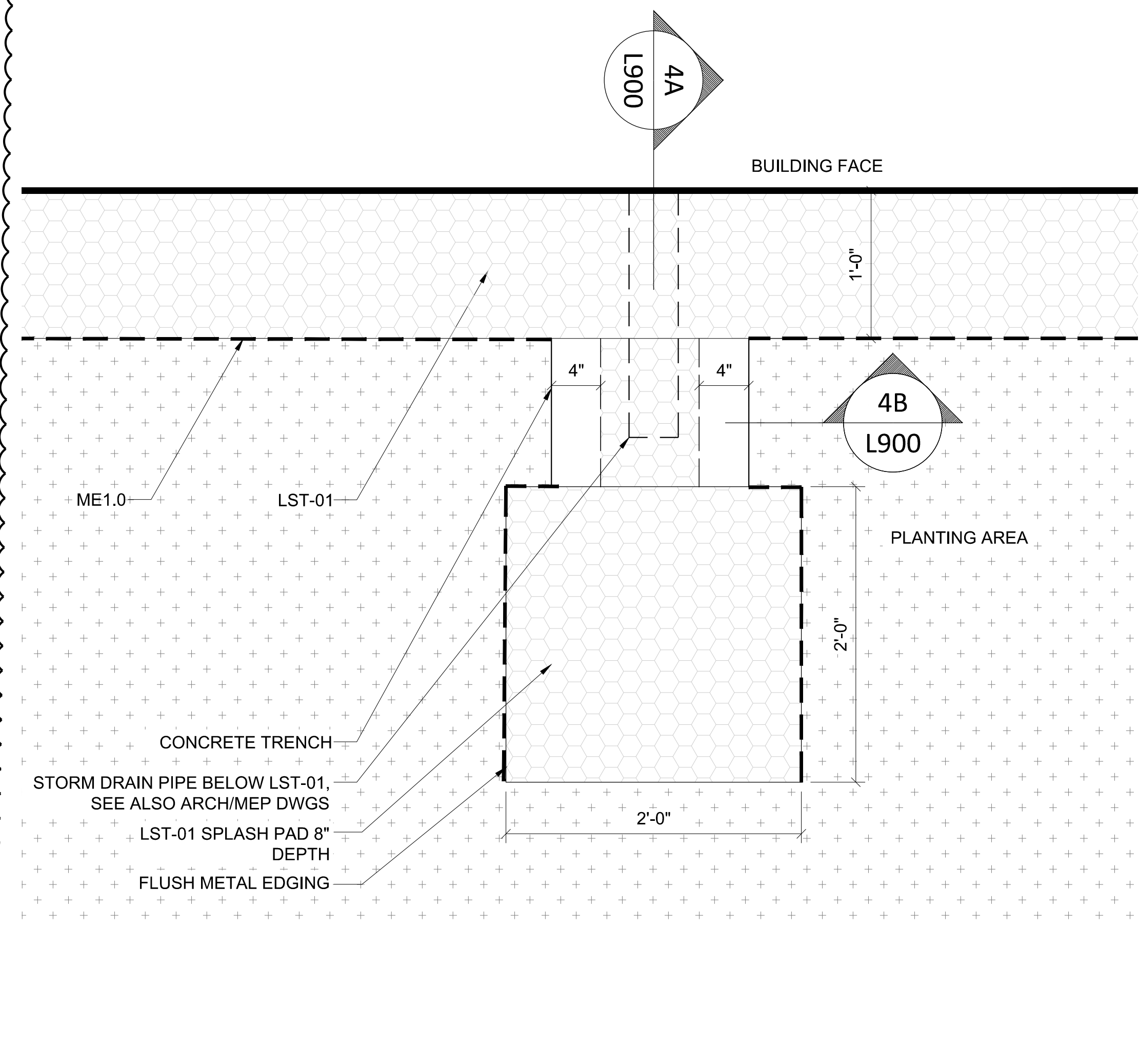

4 SPLASH PAD
SCALE: 3" = 1'-0"

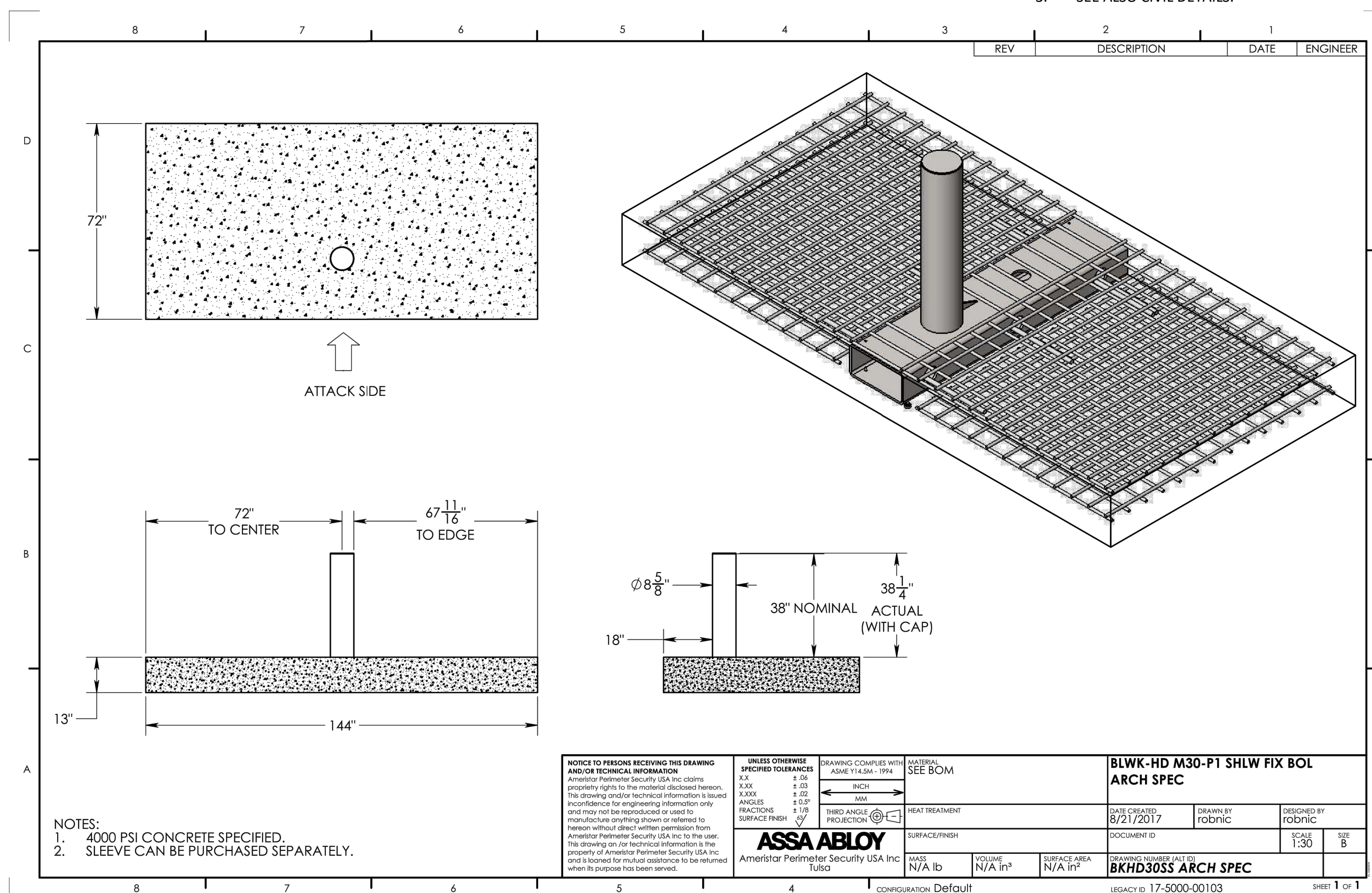

2 BOLLARD
SCALE: 1-1/2" = 1'-0"

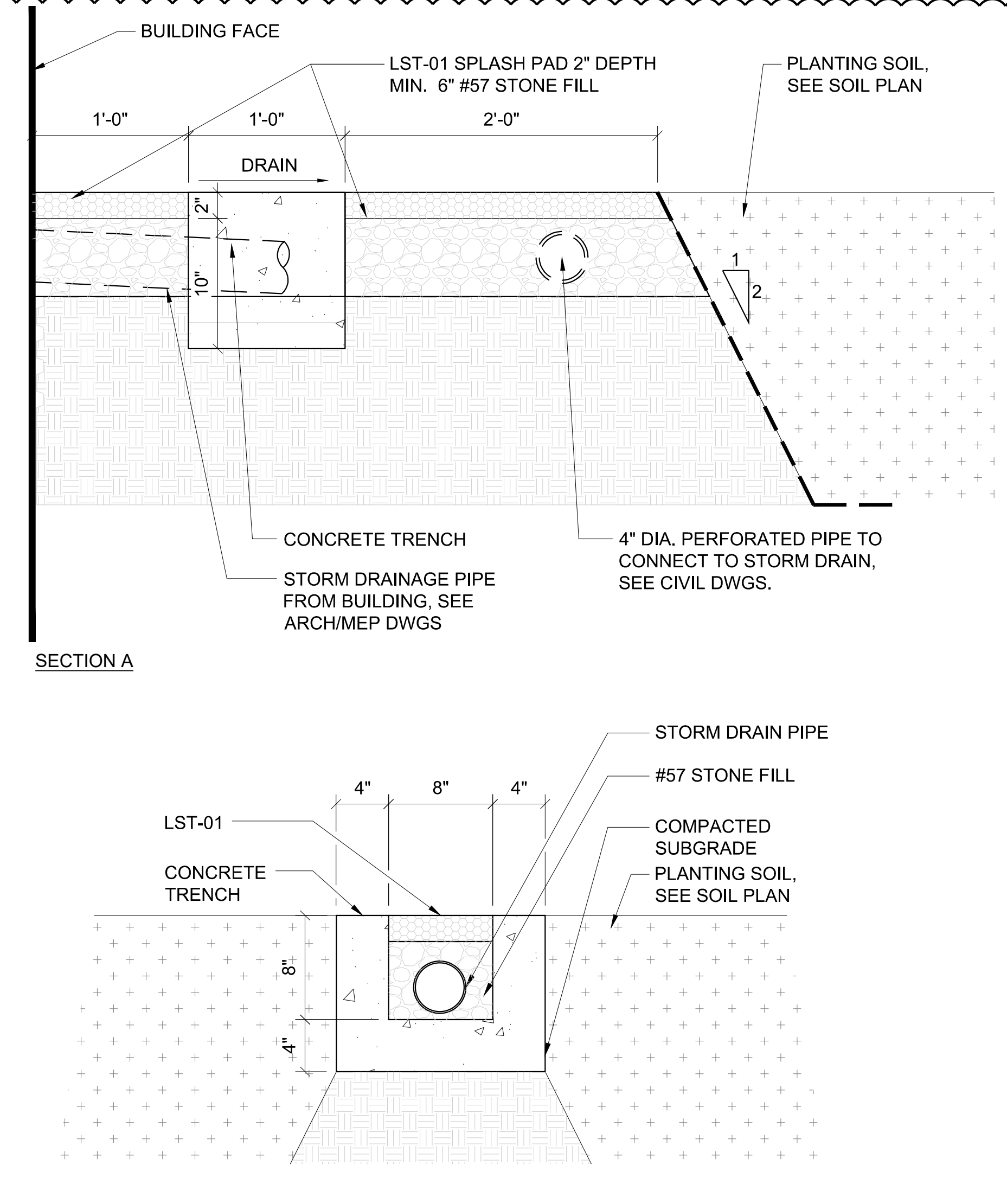

NOTE:
1. BASIS OF DESIGN IS WESTBROOK CORNERSTONE 100 WALL.
2. CMU BLOCK COLOR AND FINISH TO MATCH CMU-01.

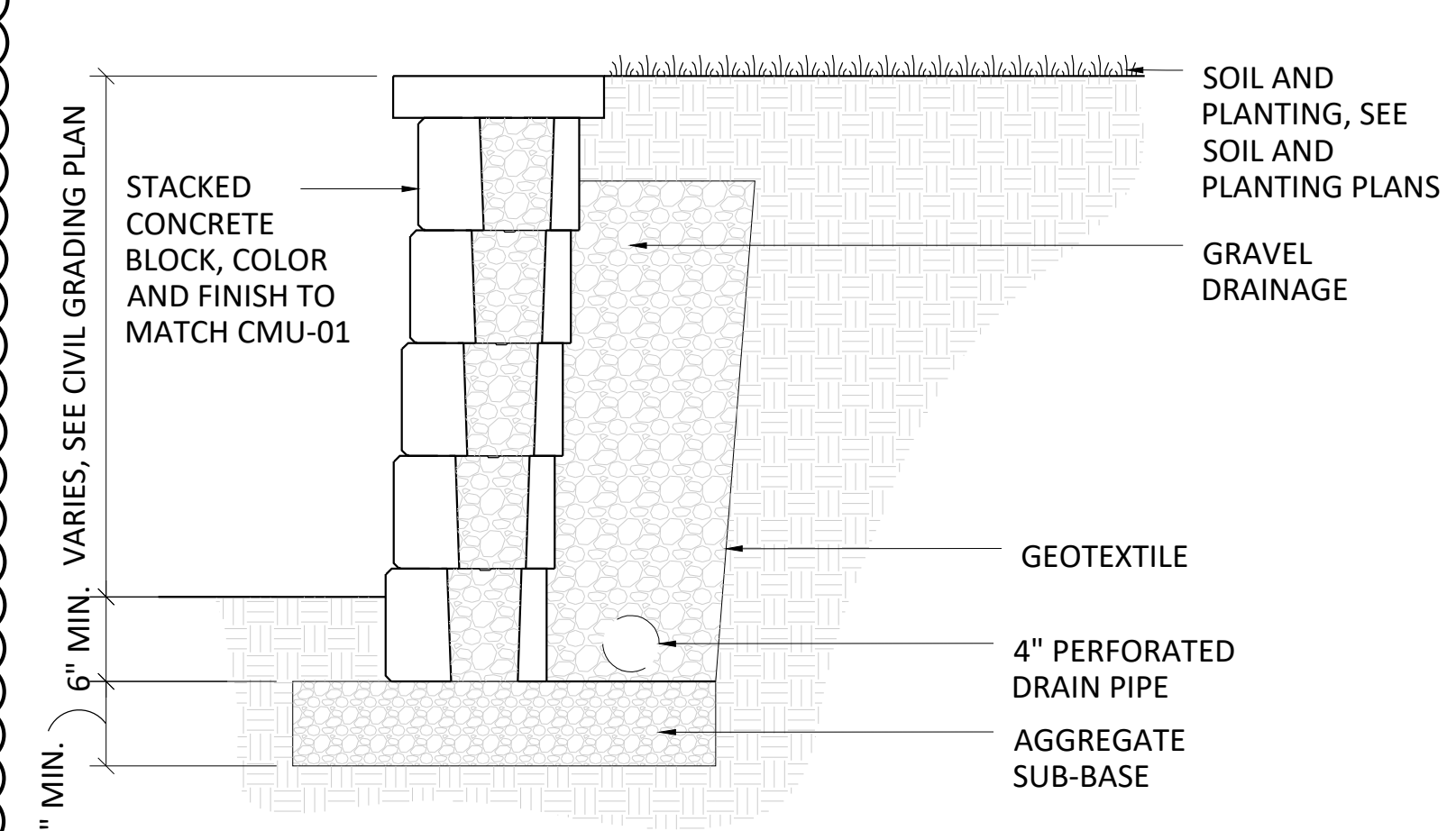

5 SITE WALL
SCALE: 1/2" = 1'-0"

- BOLLARD NOTES:**
- DELEGATED DESIGN ITEM
 - GC TO SUBMIT PA STRUCTURAL ENGINEER'S STAMPED AND SEALED SHOP DRAWING WITH FOOTER DESIGN PER MANUFACTURER'S STANDARDS AND GEOTECH REPORT FOR APPROVAL.
 - SEE ALSO CIVIL DETAILS.

- TACTICAL TRAINING DESIGN
- Tactical Design North, Inc.**
231 E. Buffalo St #502, Milwaukee, WI 53202
- LOCAL ARCHITECT
- Jacobs Wyper Architects**
1232 Chancellor St, Philadelphia, PA 19107
- STRUCTURAL ENGINEER
- Skidmore, Owings & Merrill LLP**
250 Greenwich St, New York, NY 10007
- ELECTRICAL, PLUMBING, FIRE PROTECTION, FIRE ALARM ENGINEER
- A & J Consulting Engineering Services, P.C.**
164 Brighton Rd, Clifton, NJ 07012
- MECHANICAL, AVIT ENGINEER
- Interface Engineering, Inc.**
2000 M Street NW, Suite 270, Washington, DC 20036
- ACOUSTICAL ENGINEER
- Cerami**
1001 Ave of the Americas, 4th Floor, New York, NY 10018
- CODE CONSULTING
- CCI**
215 W 40th St, 10th Floor, New York, NY 10018
- CIVIL ENGINEER
- Langan**
1818 Market St #3300, Philadelphia, PA 19103
- VERTICAL TRANSPORT
- Michael Blades & Associates Ltd.**
5409 Rapidan Ct, Lothian, MD 20711
- SIGNAGE CONSULTANT
- Patricia Hord Graphik Design**
119 S. St. Asaph St, Alexandria, VA 22314
- LANDSCAPE
- Lee and Associates, Inc.**
638 I Street NW, Washington, DC 20001
- LIGHTING
- MCLA**
1000 Patomic St NW, Suite 121, Washington, DC 20007
- FOOD SERVICE
- Hopkins Foodservice Specialists, Inc.**
7906 MacArthur Blvd, Suite 100, Cabin John, MD 20818
- POOL DESIGN
- AQUA Design International**
7536 N. La Cholla Blvd, Tucson, AZ 85741

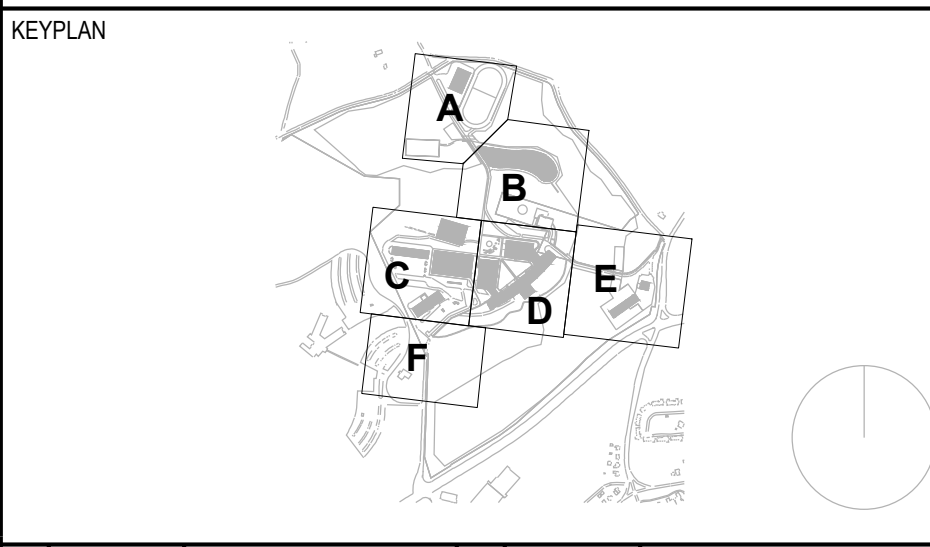

NO.	DATE	DESCRIPTION	NO.	DATE	DESCRIPTION
3	30 JUN 2023	ADDENDUM 29			
2	19 MAY 2023	ISSUED FOR BID			
1	18 FEB 2022	ISSUED TO L&I			

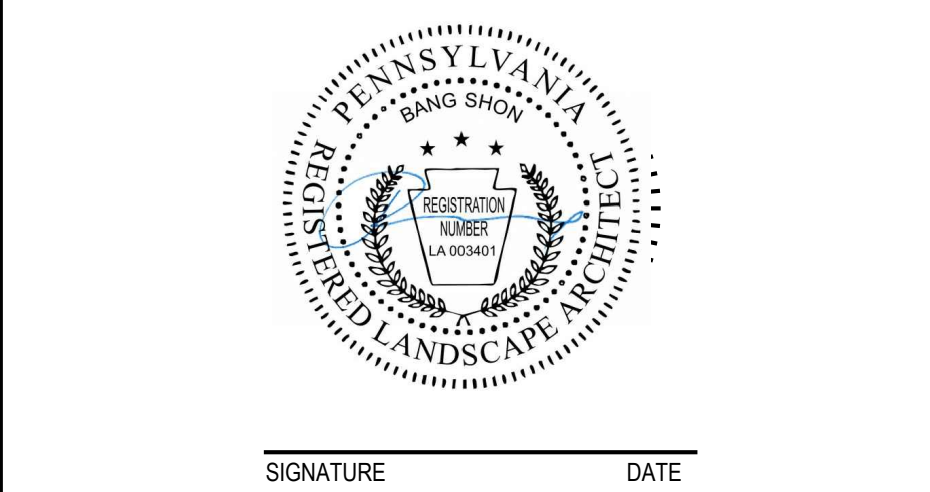

ARCHITECT

SOM
Skidmore, Owings & Merrill LLP
250 Greenwich St, New York, 10007

COMMONWEALTH OF PENNSYLVANIA
DEPARTMENT OF GENERAL SERVICES
HARRISBURG, PENNSYLVANIA

D.G.S. PROJECT No: C-0211-0005 PHASE 5

Pennsylvania State Police Academy
Core Buildings, BESO & Sitework
PENNSYLVANIA STATE POLICE
HERSHEY, DAUPHIN COUNTY, PA

VERIFY SCALE

BAR IS ONE (1) INCH LONG ON ORIGINAL DRAWING: 0 1

IF BAR IS NOT ONE (1) INCH LONG, ADJUST SCALE ACCORDINGLY

CONTRACTOR SHALL FIELD VERIFY ALL DIMENSIONS. VARIANCE FROM CONTRACT DOCUMENTS NOT PERMITTED WITHOUT PROFESSIONAL & BUREAU OF CONSTRUCTION APPROVAL.

SHEET No: STE-L-901			
DRAWN BY: LB/DJ	CHECKED BY: BS	DATE: MAY 2023	SCALE: AS NOTED